

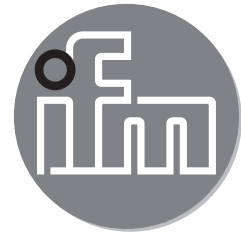

ifm electronic



Operating instructions

Safety related part IEC Ex

Flow sensors

SF*1*A

704961/00 11/2010

ifm electronic gmbh

Friedrichstraße 1

D 45128 Essen

Tel. +49 201 2 42 20

Fax: +49 201 2 42 22 00

<http://www.ifm.com>

e-mail: info@ifm.com

Function and features

In conjunction with the control monitor VS2000 Exi the flow sensor monitors flows in liquid and gaseous media and detects whether a preset flow value is reached (= medium is flowing) or not (= medium is not flowing) and provides a switching signal.

- Use in hazardous areas according to the classification

Order no.	Classification	Operating temperature range Ta
SF111A / SF211A / SF311A	Ex ia IIC T4 Ga/Gb	-20°C up to +60°

- The unit conforms to the requirements of the standards IEC60079-0:2007, IEC60079-11:2006 and IEC60079-26:2006+Corr 2009.
- IEC type test certificate

IEC Ex BVS 06. X**

Installation / Set-up

Only qualified staff is allowed to mount, connect and set up the units.

The qualified staff must have knowledge of protection classes, regulations and provisions for apparatus in hazardous areas.

Check whether the classification (see “Marking” above and marking on the unit) is suitable for the application.

- The flow sensors are only allowed to be connected to the specified control monitors type VS2000 Exi type of protection intrinsic safety [Ex ia] IIC with the IEC Ex test certificate IECEx PTB 07.0004.

Take the connection values into account.

Connection to the following control monitors is allowed:

- SN2301
- SN2302
- SR2301

- Wiring

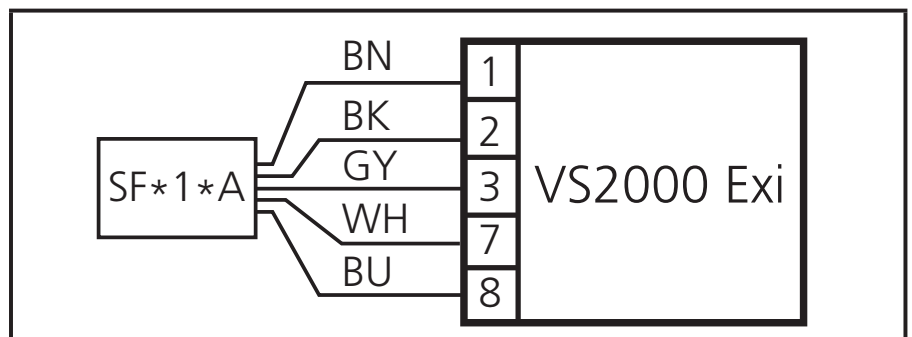

- Process connections

SF11*A = M12	SF21*A = G ¹ / ₄	SF31*A = G ¹ / ₂
--------------	--	--

- Permissible operating temperature range at the mounting location and maximum temperature range of the medium:

-20 ... +60 °C

- In principle, the type test according to IEC Ex Standards only takes atmospheric conditions (0.8...1.1 bar and mixture temperatures of -20...+60°C) into account. For pressures outside these ranges use must be assessed and approved by the user.
- Maximum effective internal inductance (Li) and capacitance (Ci) of the flow sensors (the values apply to potted cables):

Article no.	Cable length	Internal inductance (total) in µH	Internal capacitance (total) in nF
SF311A	6 m	6	1.2
SF211A	6 m	6	1.2
SF111A	6 m	6	1.2

Installation remarks / Installation

- Adhere to the relevant national regulations and provisions.
- The relevant installation regulations must be adhered to.
- Avoid electrostatic charging on plastic parts and cables.
- Protect the units efficiently against damage.
- The cable must be firmly laid and protected efficiently against damage.
- Steps must be taken to ensure the equalisation of potential of metal parts (housing and fixing material).
- The unit is suitable for installation in the partition Ga/Gb. Please take the special conditions for safe operation into account.

Special conditions for safe operation

The unit is suited for installation in the partition (Ga/Gb); e.g. tank, pipes. Sealing at the transition (Ga/Gb) must be rated according to the conditions of the corresponding application. The part of the sensor housing of corrosion-resistant steel (316S12) which reaches into the zone 0 has a wall thickness of minimum 0.6 mm due to function. In the application the user must ensure that in this area risks, e.g. due to aggressive media or mechanical hazards, are excluded.

Mounting in pipes or tanks:

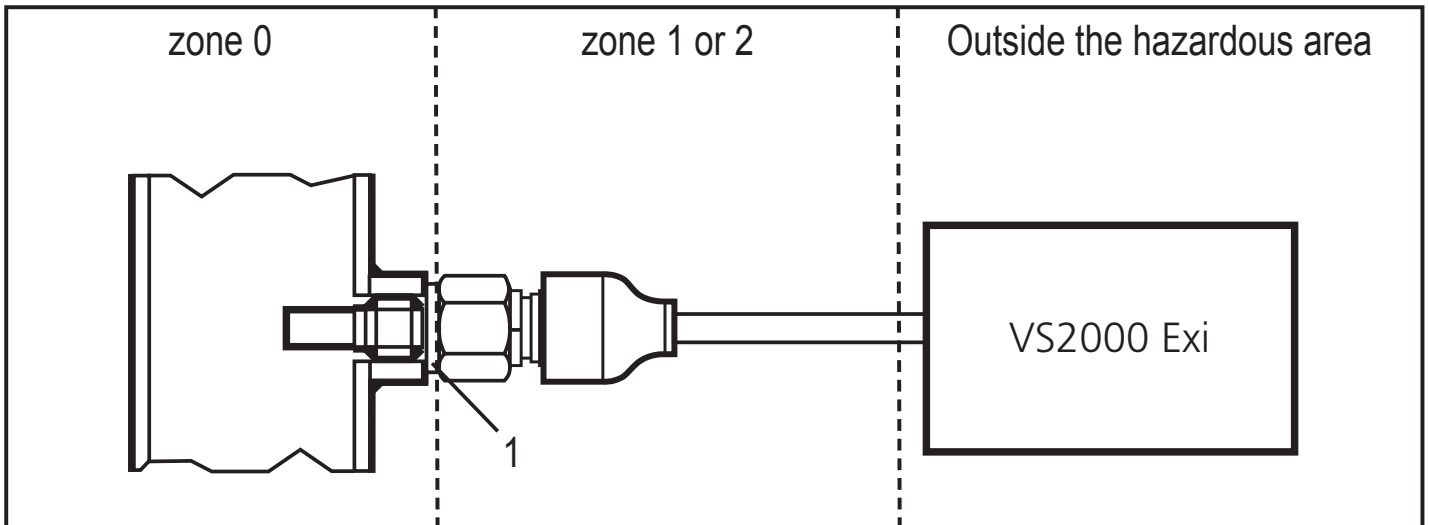

1: seal

Maintenance / Repair

- The flow sensor has to be included in the recurrent pressure test of the tank or pipe.
- The unit must not be modified nor can it be repaired. In case of a fault please contact the manufacturer.
- If needed, you can obtain data sheets or IEC Ex type test certificates from the manufacturer (see cover sheet / back).

Scale drawings and notes for the correct installation are given in the separately enclosed part of the operating instructions („Operating instructions / Installation instructions“).