

ifm electronic



Operating instructions
Electronic rising stem valve sensor

efector180[®]

IX5030

UK

704770 / 00 04 / 2010

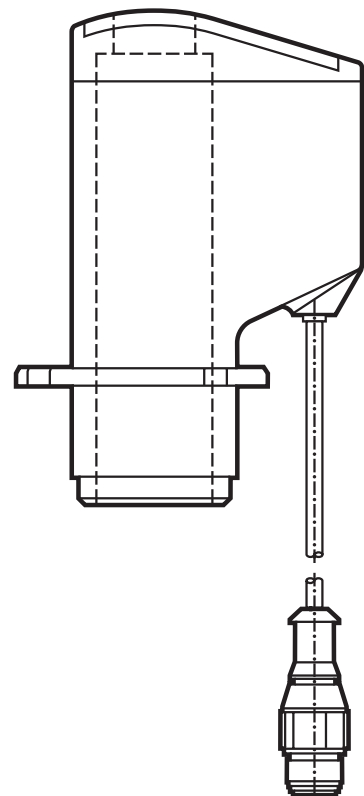

Contents

1 Preliminary note.....	3
1.1 Symbols used	3
2 Functions and features	4
2.1 Permissible shapes and dimensions of the target	5
2.2 Non-permissible shapes and dimensions of the target.....	5
3 Function description.....	6
3.1 Application example.....	6
4 Installation.....	7
5 Electrical connection.....	8
5.1 Assignment of the data bits	8
6 Operation	9
7 Programming	9
7.1 Programming overview	9
7.2 Adjustment of the valve positions of valves with 2 operating positions	11
7.3 Adjustment of the valve positions of valves with 3 operating positions	12
7.4 Locking /unlocking	13
8 Set-up/operation	13
8.1 Indication by LED for the different operating modes.....	13
9 Error messages	15
10 Scale drawing	16

1 Preliminary note

1.1 Symbols used

▶ Instruction

> Reaction, result

→ Cross-reference



Important note

Non-compliance can result in malfunction or interference.



Information

Supplementary note.

2 Functions and features

The rising stem valve sensor IX5030 is a continuous absolute linear measurement system with a measuring stroke of 80 mm. The sensor is used for position feedback for rising stem valves. For position detection three programmable switch points can be freely selected in the measuring range. The position is signalled visually by 3 LEDs.

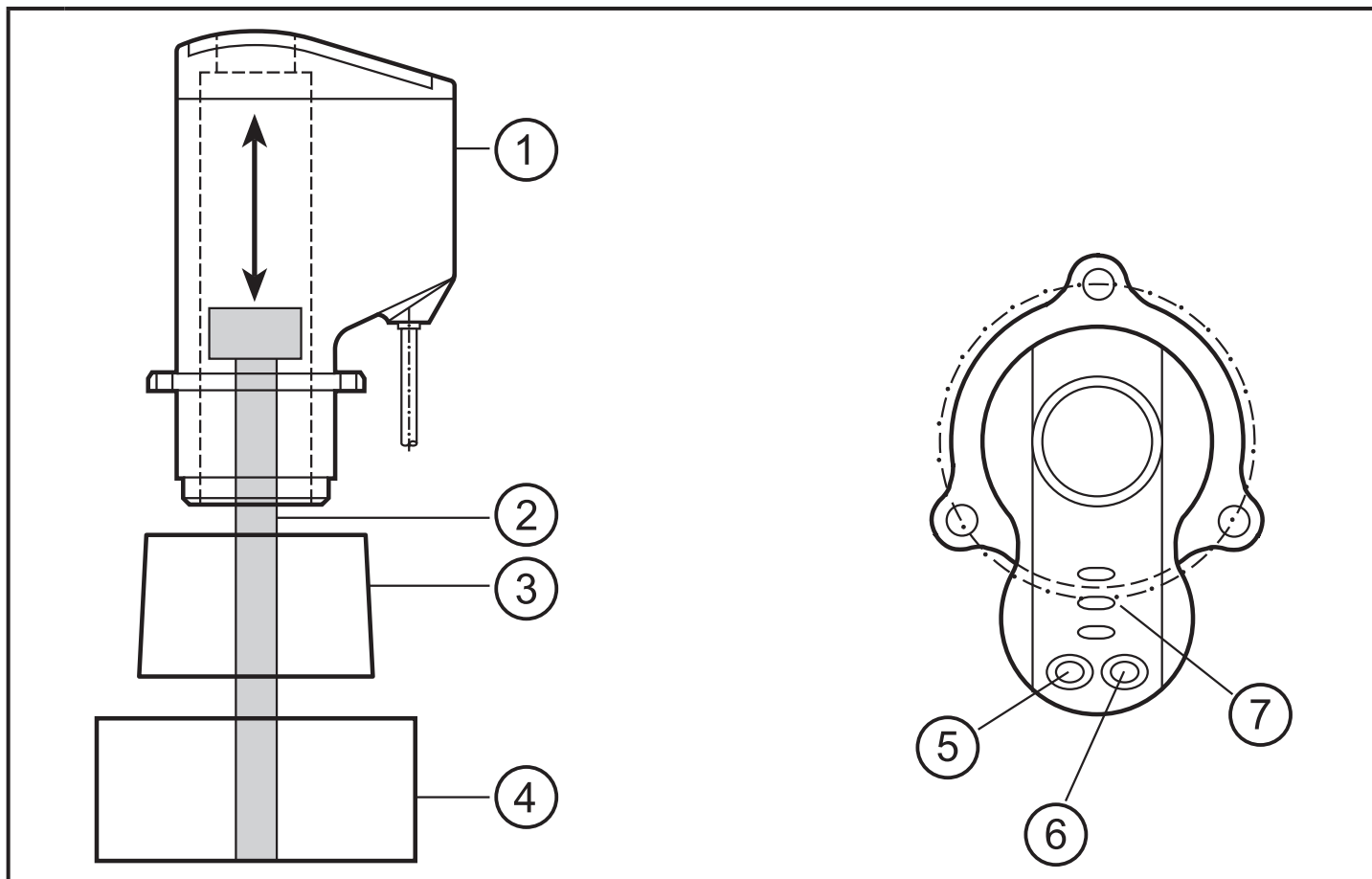

- ① sensor
- ② valve spindle with target
- ③ adapter / fixture
- ④ actuator of the valve
- ⑤ position button
- ⑥ Teach button
- ⑦ 5 LEDs (open, close, seat, AS-i voltage, error)



The rising stem valve sensor IX5030 can be adapted to different valve types. The instructions in the chapter Installation are to be observed when designing the adapters and the fixtures.

The valve spindle to be measured must have the following characteristics:

- Diameter 24 mm (tolerance: ± 0.05 mm), height at least 10 mm
- The end surface must be flat
- Material: stainless steel to DIN 17440, material number 316L / 1.4404

2.1 Permissible shapes and dimensions of the target

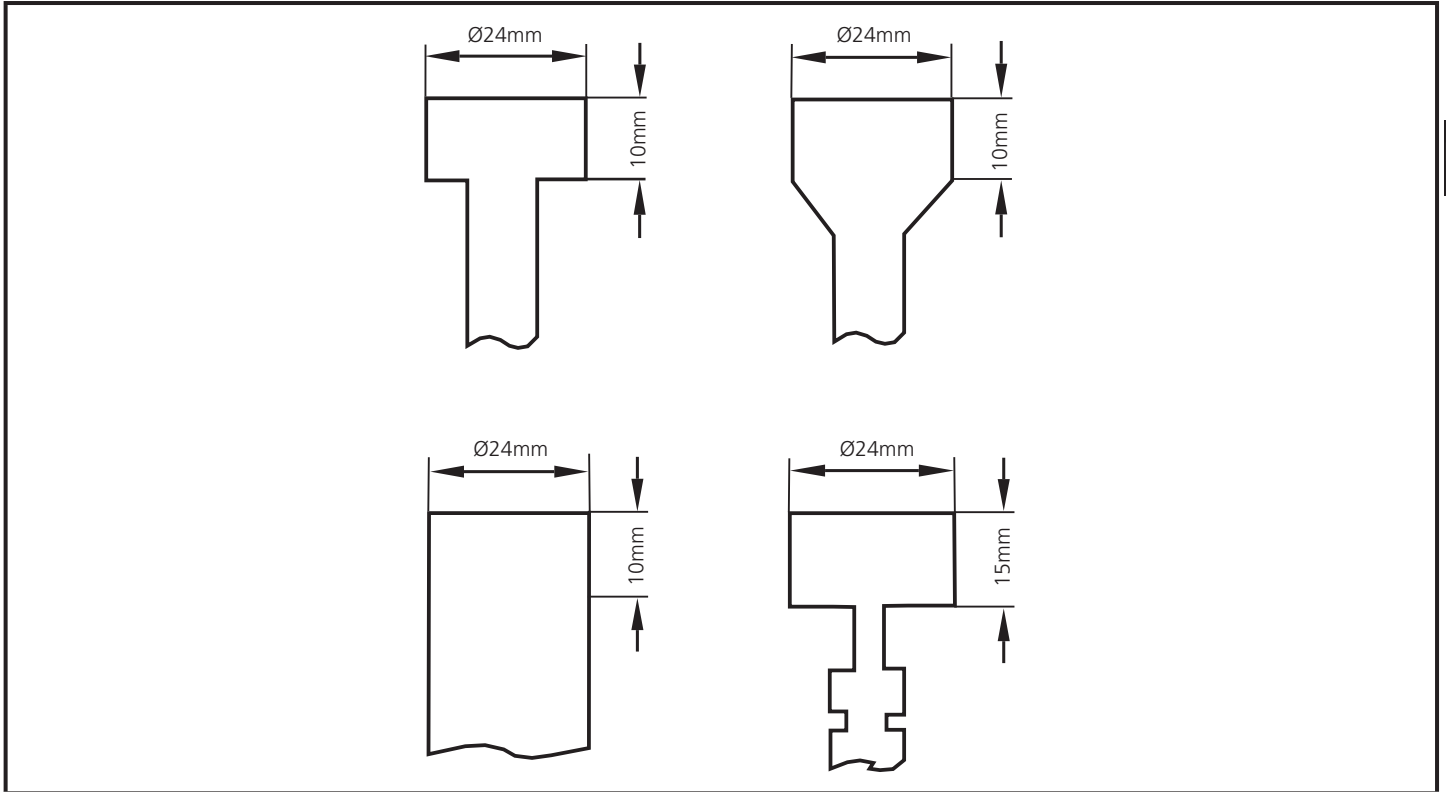

UK

2.2 Non-permissible shapes and dimensions of the target

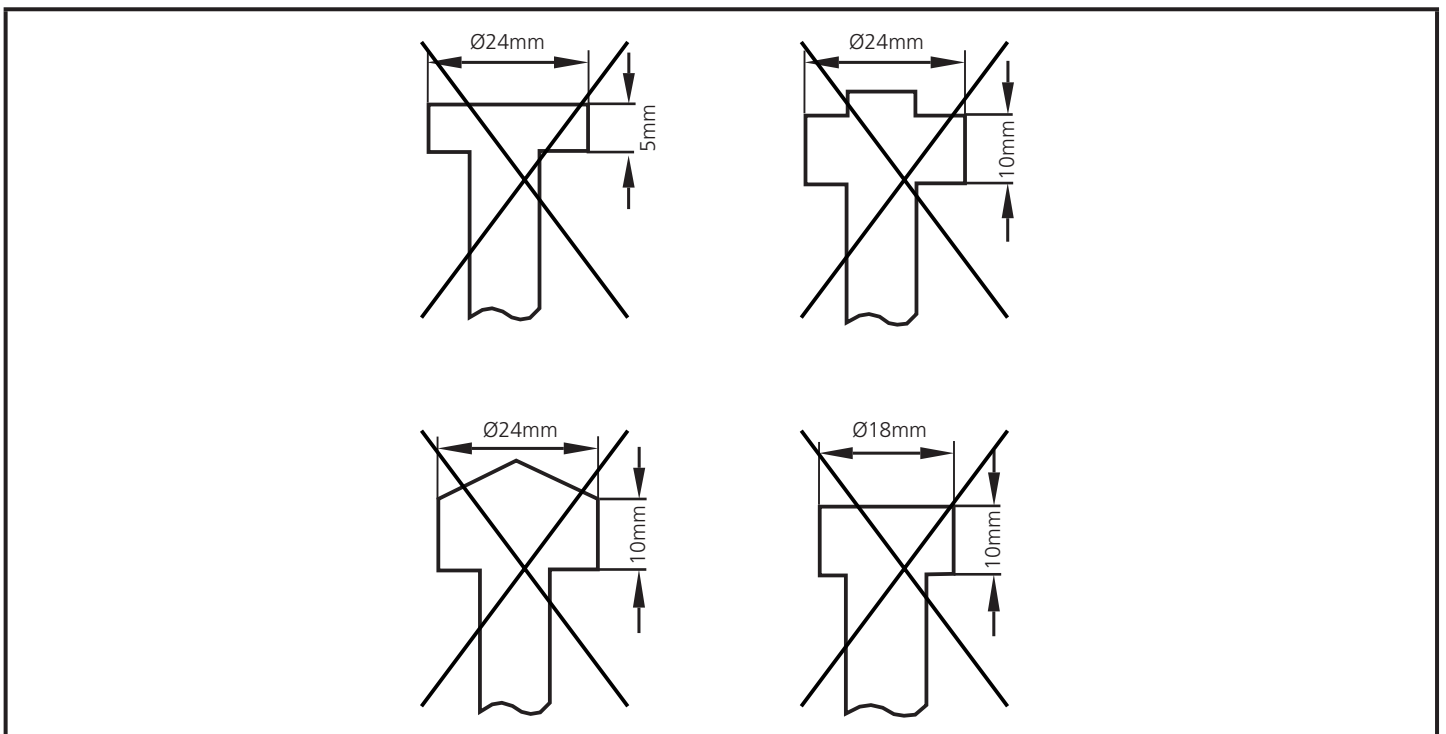

3 Function description

- The sensor measures the upper edge of the valve spindle
- Non-contact and wear-free detection of the valve positions: closed (close), open (open) and the position for seat lift (seat) during the cleaning process.
- It is also possible to monitor the state of the valve seals instead of the seat lift. Due to the high resolution of 0.2 mm even slight changes can be detected.
- Easy and time-saving adjustment by "teaching" (reading) the valve positions. The taught valve positions are automatically assigned certain switching characteristics of the three outputs, several operating modes are available (see chapters Programming and Set-up).
- Monitored stroke (detection zone) 80 mm. The condition "valve spindle outside detection zone" is indicated.
- After adjustment the unit can be electronically locked to prevent unauthorised manipulation.

3.1 Application example

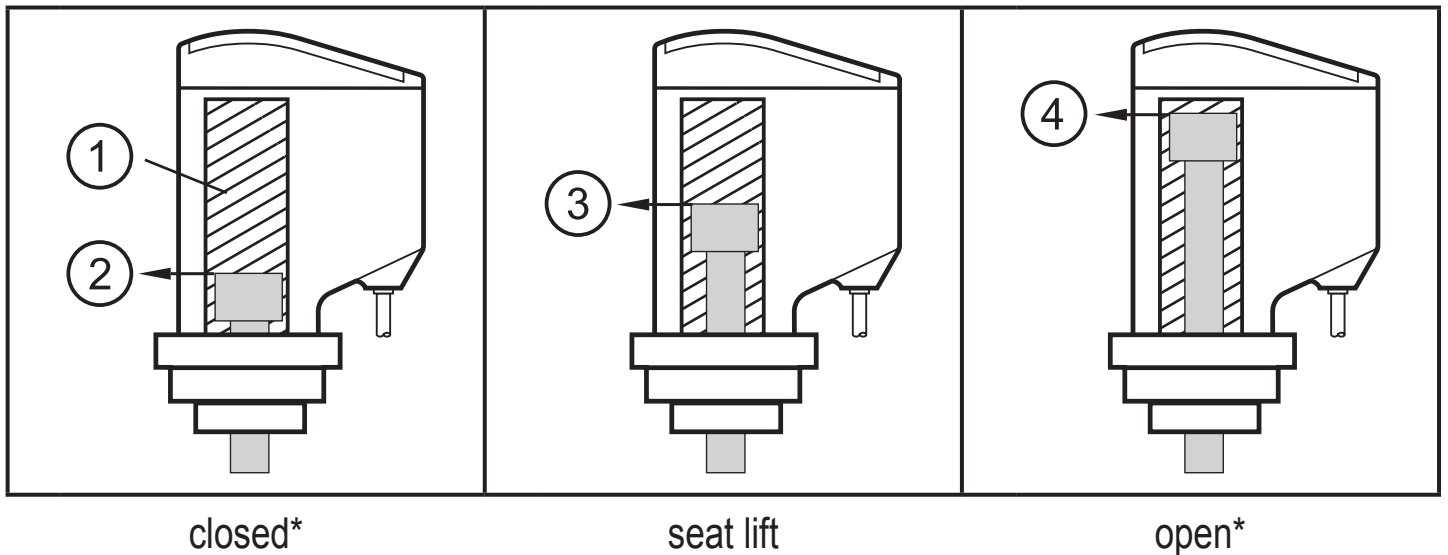

- ① Active detection range of the sensor ③ Position seat lift is taught ④ Open position is taught
② Closed position is taught

* The valve positions closed and open may also be reversed.

4 Installation

Place the sensor (1) on the valve spindle (2) until the limit stop in a suitable fixture / adapter (3).

Fix the sensor to the 3-hole flange (3) by means of the included fixing screws (6).

The sensor (1) must either be integrated into a valve top or correctly fitted to the actuator (4) by means of a suitable adapter (3).

If necessary adapt the length of the valve spindle to the measuring range.

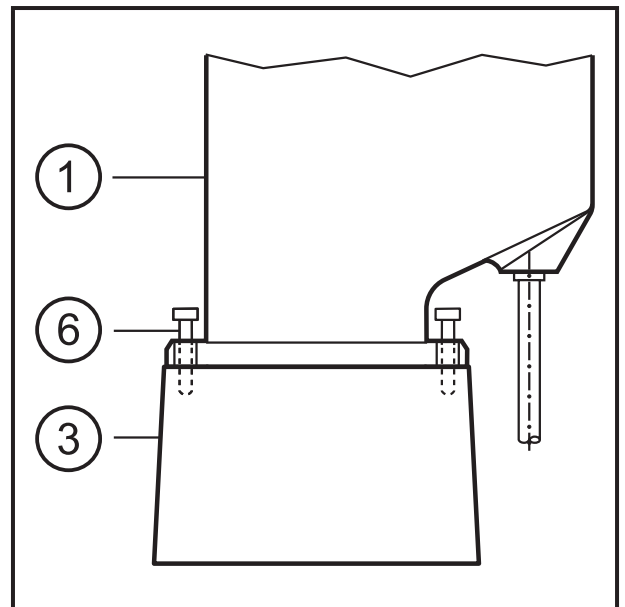
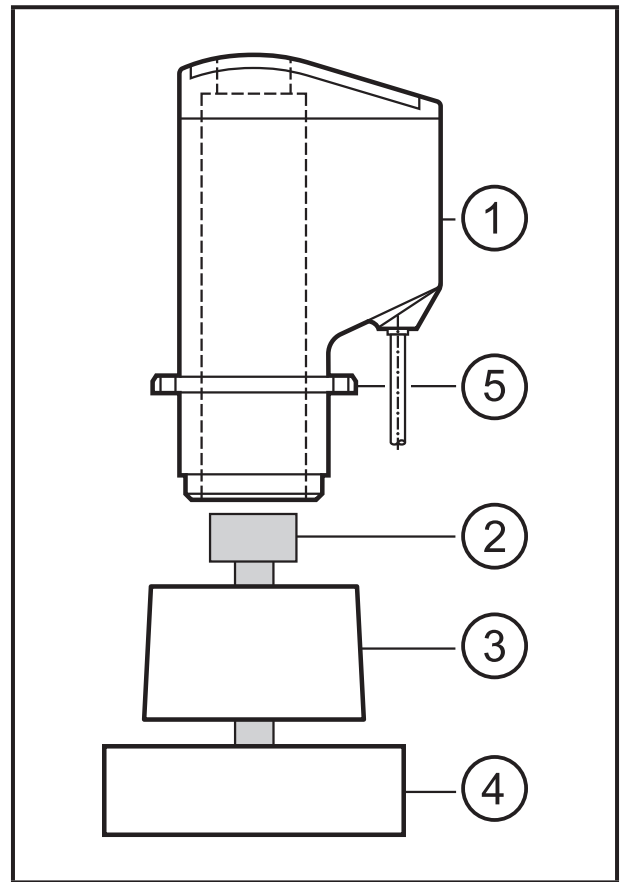

UK

Ensure a tight and secure fit.

Make sure that no metallic components are in the immediate vicinity of the sensor or approach the sensor during operation (especially no metal rings which enclose the sensor)! This might affect the functioning of the sensor.

Fixing elements such as screws, clamps and similar small metal parts (< 20 x 20 x 30 mm) have no impact on the sensor. For safe functioning the adapter (3) must be made of plastic.

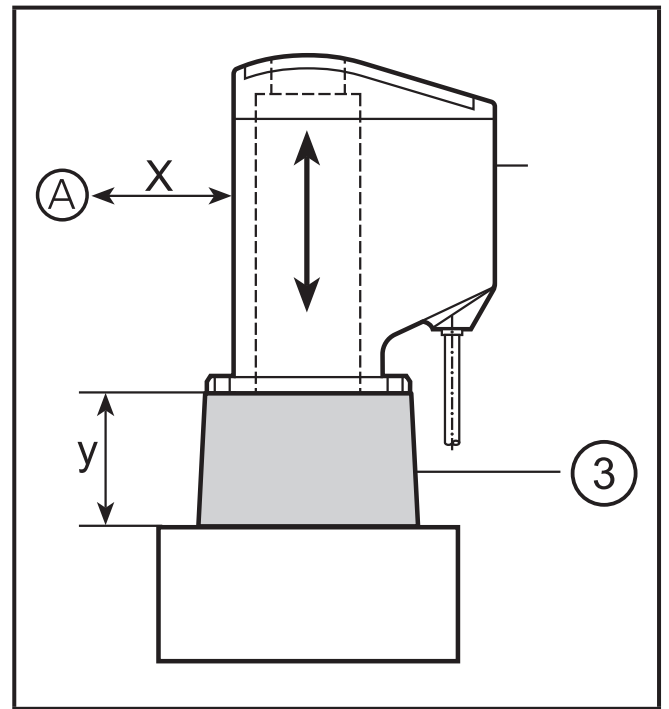

A = metallic objects
 x = min. 10 mm
 y = min. 46.5 mm

5 Electrical connection

The unit must be connected by a qualified electrician. The national and international regulations for the installation of electrical equipment must be adhered to.

Disconnect power before connecting the unit as follows:

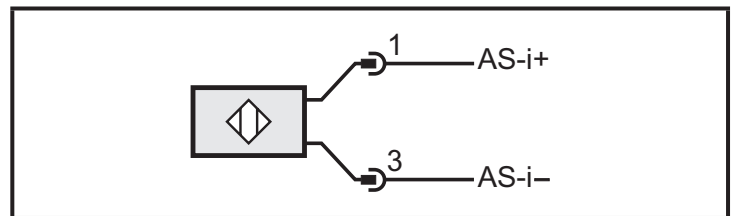

5.1 Assignment of the data bits

Data bit	D0	D1	D2	D3
Description	close	seat	open	not used
state = 0	plunger outside the 'close' zone	plunger outside the 'seat' zone	plunger outside the 'open' zone	default value
state = 1	plunger inside the 'close' zone	plunger inside the 'seat' zone	plunger inside the 'open' zone	-

6 Operation

The sensor is operated via the pushbuttons Pos. and Teach. To do so, press the buttons with a blunt object.



Sharp edges may damage the buttons!

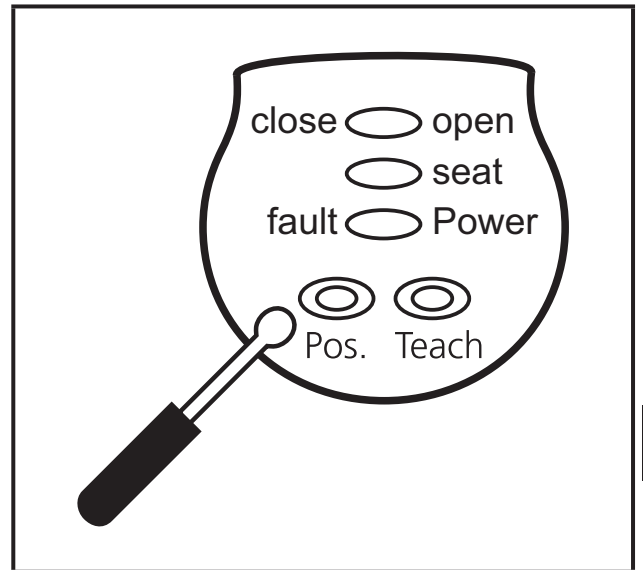

UK

7 Programming

7.1 Programming overview

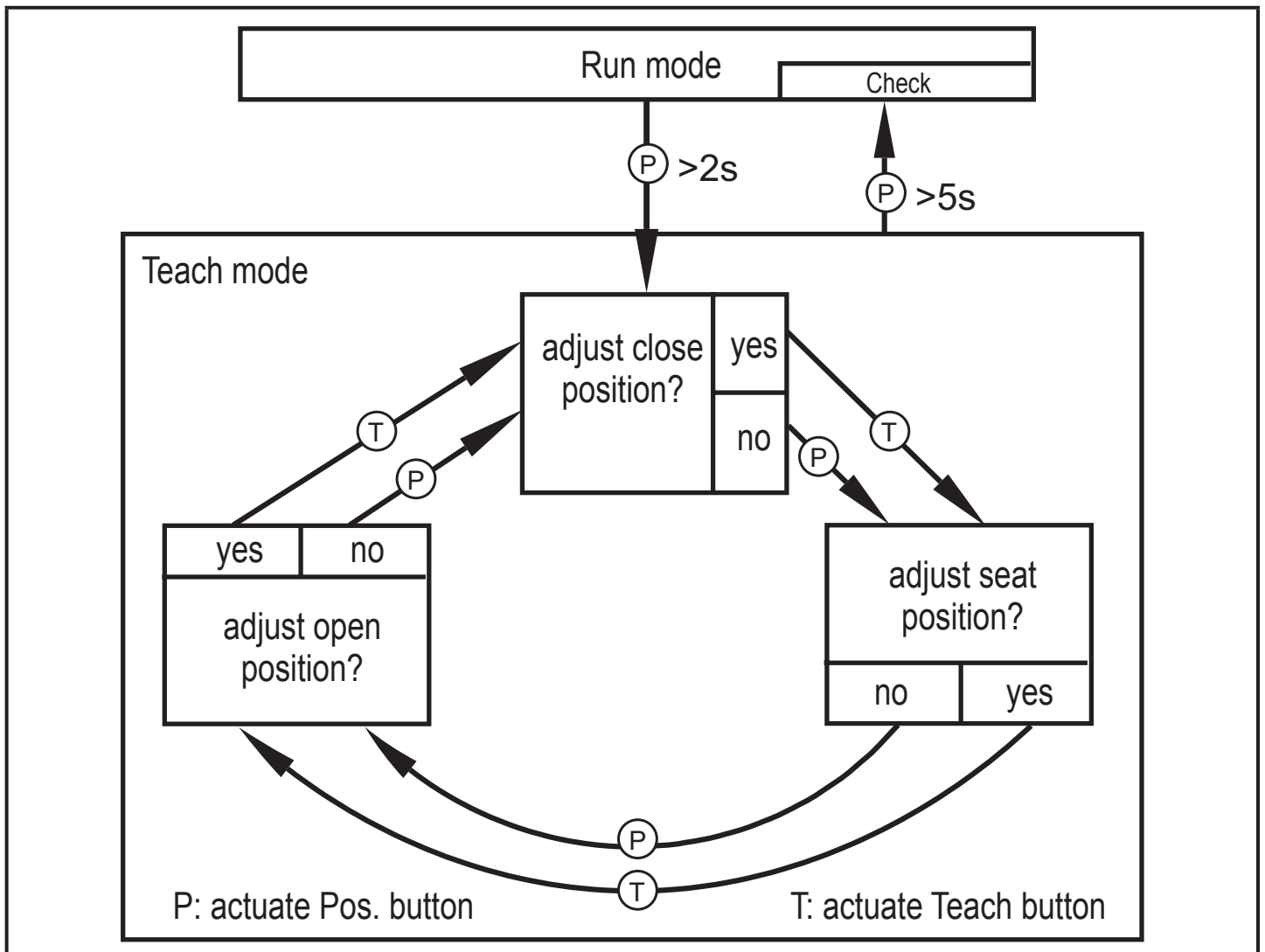

After installation you have to adjust the unit to the valve positions to be detected. You can carry out the adjustment process in a variable and time-saving way. First clarify which type of valve you have. The sensor differentiates between two types:

1. Valves with 2 operating positions (closed and open)
2. Valves with 3 operating positions (closed, open and a position inbetween for the seat lift)

For valves with 2 operating positions the wear of the valve seals is monitored automatically. This function is not possible for the detection of three operating positions.

The programming options are shown in the programming overview (→ 7.1) After entering into the programming mode (Teach mode) the unit first expects the adjustment of the closed position (close).

However, you can also start with any other position.





If e.g. the valve is already in the open position (open), just start adjusting this position. To do so, press the Pos. button 2 x, thus skipping the adjustment of the closed and the seat position. You can carry out the skipped adjustment steps afterwards.

Skipping a current programming step is also required for example if you use valves with only 2 operating positions for which the position of the seat lift is not available. If the position seat lift is not adjusted ("taught") the unit automatically passes into an operating mode which monitors the wear of the valve seals (see also chapter Set-up / operation).







The unit cannot be taught via the AS-i bus.

7.2 Adjustment of the valve positions of valves with 2 operating positions

1	Press the Pos. button for at least 2 s.		All LEDs flash 2 x simultaneously. The unit is in the programming mode. Then only the LED "close" is lit. The unit is now ready for the adjustment of the closed position (close).
2	Put the valve into the closed position and press the Teach button.		The LED "close" goes out and the LED "seat" lights. The unit has stored the closed position and is now ready for the adjustment of the position seat lift (seat).
3	Press the Pos. button once, thus skipping the current programming step. This is necessary because your valve does not have the position seat lift.		The LED "open" lights. The unit is now ready for the adjustment of the open position.
4	Put the valve into the open position and press the Teach button.		The LED "open" goes out and the LED "close" lights again. The unit has now stored all positions.
5	Press the Pos. button for at least 5 s. After 5 s the LED "open" flashes at about 2 Hz.		After releasing all stored measured values are checked. If no errors are detected all LEDs simultaneously flash 2 x. The unit automatically quits the programming mode and immediately passes into the operating mode. If, however, an error is found during the check the LED "close" flashes at about 8 Hz. Acknowledge the error message by pressing the Pos. button and repeat the adjustment.

7.3 Adjustment of the valve positions of valves with 3 operating positions

1	Press the Pos. button for at least 2 s.		All LEDs flash 2 x simultaneously. The unit is in the programming mode. Then only the LED "close" is lit. The unit is now ready for the adjustment of the closed position (close).
2	Put the valve into the closed position and press the Teach button.		The LED "close" goes out and the LED "seat" lights. The unit has stored the closed position and is now ready for the adjustment of the position seat lift (seat).
3	Put the valve into the position seat lift and press the Teach button.		The LED "seat" goes out and the LED "open" lights. The unit has stored the position seat lift and is now ready for the adjustment of the open position (open).
4	Put the valve into the open position and press the Teach button.		The LED "open" goes out and the LED "close" lights again. The unit has now stored all positions.
5	Press the Pos. button for at least 5 s. After 5 s the LED "open" flashes at about 2 Hz.		After releasing all stored measured values are checked. If no errors are detected all LEDs simultaneously flash 2 x. The unit automatically quits the programming mode and immediately passes into the operating mode. If, however, an error is found during the check the LED "close" flashes at about 8 Hz. Acknowledge the error message by pressing the Pos. button and repeat the adjustment.

7.4 Locking/unlocking

The unit can be locked electronically to prevent unintentional operations.

Press both setting pushbuttons simultaneously for at least 10 s in the operating mode. After 10 s each LED lights briefly one after the other. Then the unit is locked or unlocked.

In the locked state operations are ignored.

On delivery: unlocked.

8 Set-up/operation

UK

After installation, wiring and adjustment check whether the unit operates correctly. If possible, put the valve into all available positions and check whether the unit switches correctly and whether the operations are correctly indicated by the LEDs.

8.1 Indication by LED for the different operating modes

The sensor has 3 operating modes which the sensor automatically generates depending on the programming.

- Mode A:
For valves with 2 operating positions. The wear of the valve seals is monitored.
- Mode B:
For valves with 3 operating positions. The position seat lift (seat) is between the positions closed and open.
- Mode C:
For valves with 3 operating positions. The position seat lift (seat) is outside the positions closed and open.

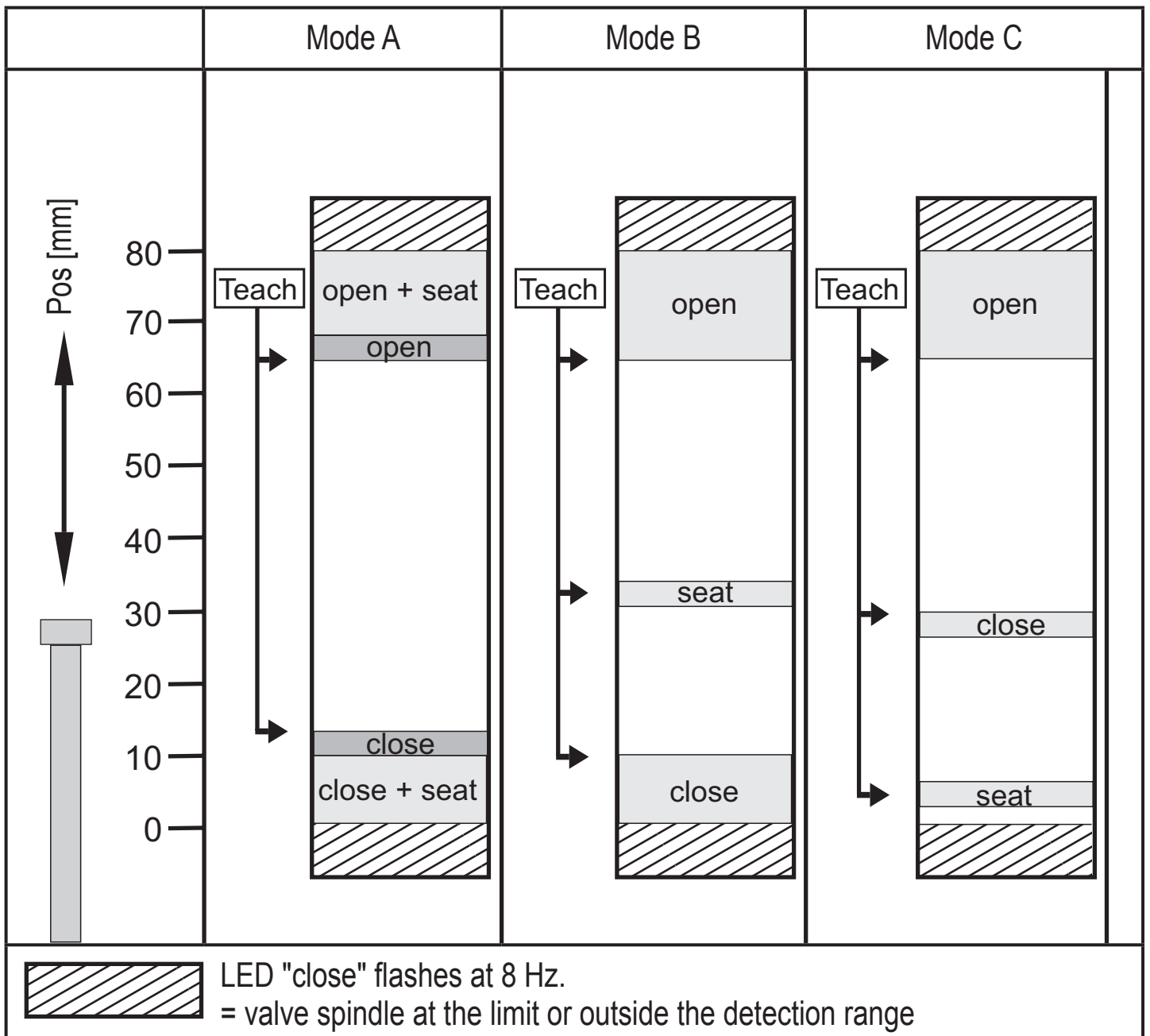

- The respective LED at the zones marked in grey lights, at the same time the output corresponding to this state is closed (switched). At the zones marked in white and outside the detection area (zones hatched diagonally) all outputs are open (not switched).
- All modes are also possible in inverted form, i.e. the open and closed positions can be inverted. The sensor detects this automatically, the assignment of the switching characteristics is carried out automatically.
- The open and closed zones are placed nearly at the limits, i.e. the Teach positions are at the limit of the zones. The seat zones are placed in the middle, i.e. symmetrically around the Teach position.
- To monitor the seal the open and closed zones in the mode A are only 1.5 mm. The zones open+seat and close+seat are adjacent. In these zones the

outputs "open" and "seat" and the outputs "close" and "seat" are switched simultaneously. This signals wear of the valve seal!!

- In the mode A only 2 valve positions are to be adjusted, the positions closed and open. The adjustment of the seat lift must not be carried out, please skip this program step by pressing the Pos. button. The sensor then automatically generates the mode A.

9 Error messages

	LED	Fault description	Measure
during adjustment	close	Flashes at 8 Hz directly after leaving the programming mode = adjustment error! Taught position values are not within the detection range or positions are not allowed or plausible.	▶ Acknowledge the error message by pressing the Pos. button and repeat the adjustment.
during operation	close	Flashes at 8 Hz = target is at the limit or outside the detection range or the target is in non defined zones (white zones, see above diagram) for longer than 20 s.	▶ Check the position of the valve.
	close	Flashes at 8 Hz = fault in the electronics. Contrary to the other error messages this error message cannot be acknowledged or terminated.	▶ Replace the sensor.

UK

10 Scale drawing

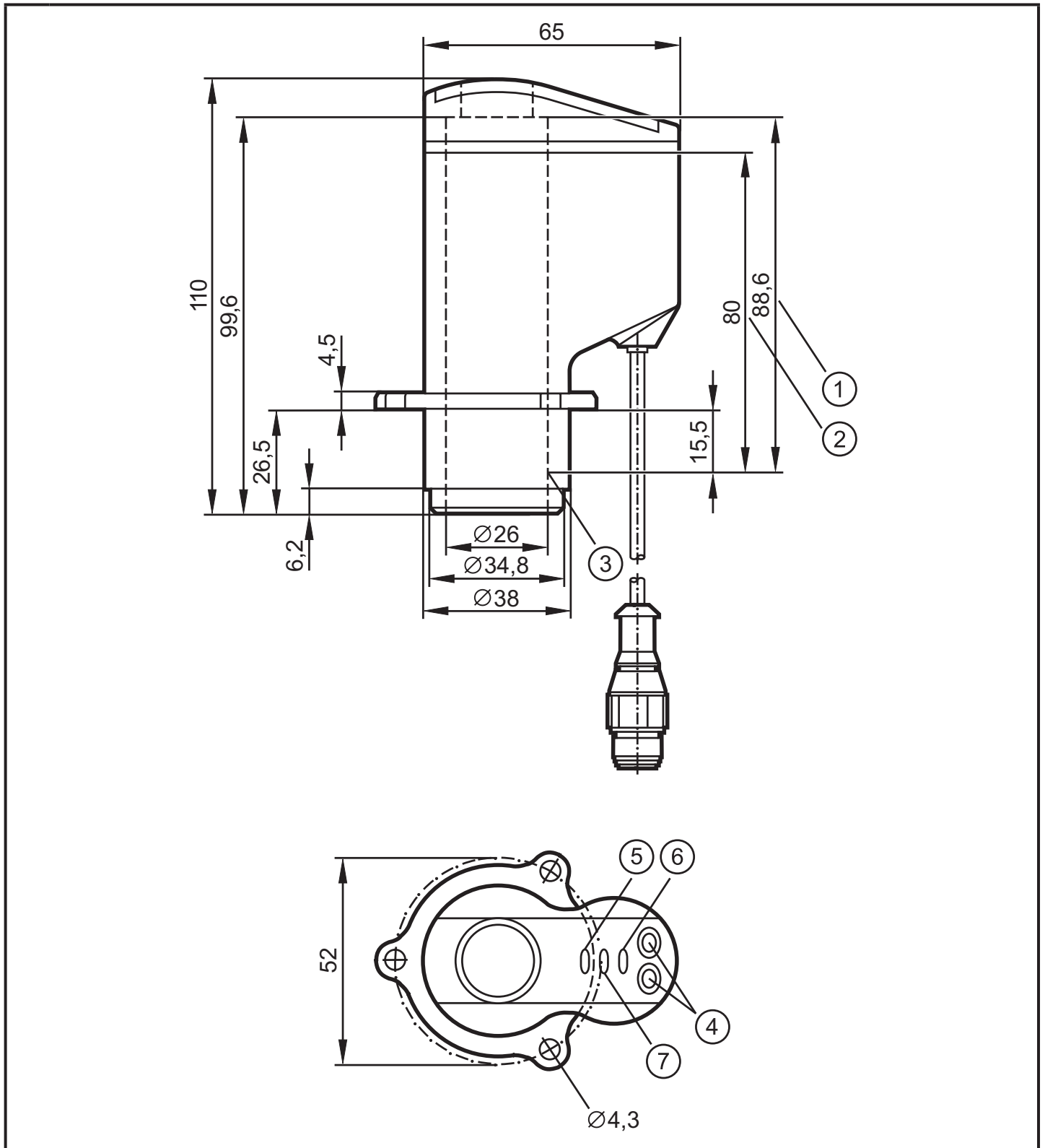

- ① Max. spindle stroke
- ② Measuring distance
- ③ Initial value of the measuring range (zero point)
- ④ Programming buttons (Pos. / Teach)
- ⑤ LED green = open / LED red = close
- ⑥ LED green = AS-i voltage / LED red = error
- ⑦ LED yellow = seat

