



Operating instructions

AC2256

AC2258

GB

11467554 / 00 08 / 2022



Contents

1	Preliminary note	3
1.1	Symbols used	3
1.2	Safety symbol on the device	3
1.3	Warnings used	3
2	Safety instructions	4
3	Intended use	5
4	Installation	6
4.1	Installation location	6
4.2	Installation of the device	6
4.3	Identical devices mounted side by side	6
4.4	Deratings for side by side mounting of identical devices	7
4.5	Side by side mounting of different devices	7
4.6	Removing the device	8
4.7	Installation of the sensors	8
5	Electrical connection	9
5.1	General wiring information	9
5.2	Wiring	10
5.2.1	Digital input and output module AC2256	10
5.2.2	Digital input and output module AC2258	11
5.3	Safety instructions relay connections	11
5.4	Connection technology	12
5.5	Connection accessories	12
6	Set-up / addressing	13
6.1	Addressing with the AC1154 addressing unit	13
7	Operating and display elements	14
7.1	Operation / LEDs	14
7.2	Scale drawing	15
8	Maintenance, repair and disposal	16
8.1	Maintenance	16
8.2	Cleaning the housing surface	16
8.3	Repair	16
8.4	Disposal	16

1 Preliminary note

You will find instructions, technical data, approvals, accessories and further information using the QR code on the device / packaging or at www.ifm.com.

1.1 Symbols used

- ✓ Requirement
- ▶ Instructions
- ▷ Reaction, result
- [...] Designation of keys, buttons or indications
- Cross-reference
-  Important note
Non-compliance may result in malfunction or interference.
-  Information
Supplementary note



1.2 Safety symbol on the device



Safety symbol on the device:

- ▶ Adhere to the operating instructions for the safe operation of the unit.

1.3 Warnings used

	<p>ATTENTION</p> <p>Warning of damage to property</p>
	<p>CAUTION</p> <p>Warning of personal injury</p> <p>▷ Slight reversible injuries may result.</p>
	<p>WARNING</p> <p>Warning of serious personal injury</p> <p>▷ Death or serious irreversible injuries may result.</p>

2 Safety instructions

- The unit described is a subcomponent for integration into a system.
 - The system architect is responsible for the safety of the system.
 - The system architect undertakes to perform a risk assessment and to create documentation in accordance with legal and normative requirements to be provided to the operator and user of the system. This documentation must contain all necessary information and safety instructions for the operator, the user and, if applicable, for any service personnel authorised by the architect of the system.
- Read this document before setting up the product and keep it during the entire service life.
- The product must be suitable for the corresponding applications and environmental conditions without any restrictions.
- Only use the product for its intended purpose (→ Intended use).
- If the operating instructions or the technical data are not adhered to, personal injury and/or damage to property may occur.
- The manufacturer assumes no liability or warranty for any consequences caused by tampering with the product or incorrect use by the operator.
- Installation, electrical connection, set-up, operation and maintenance of the product must be carried out by qualified personnel authorised by the machine operator.
- Protect units and cables against damage.
- Replace damaged units, otherwise the technical data and safety will be impaired.
- Observe applicable documents.

3 Intended use

- The devices act as digital input and output modules in the AS-i network. They connect max. 4 sensors (2-wire or 3-wire sensors) and max. 4 actuators each with the AS-i master.
- Outputs (relays) for direct control of contactors, smaller drives, valves, etc.
- In the control cabinet in an industrial environment (indoors) as a permanently installed device with supply from SELV/PELV according to the technical data.

Operation by trained, authorised specialist personnel due to protection class IP20.

AC2256: 4 digital inputs / 2 digital outputs (relay), sensor supply from AS-i

AC2258: 4 digital inputs / 4 digital outputs (relay), sensor supply from AS-i

4 Installation

4.1 Installation location

To ensure correct operation, install the device in a housing that can only be opened using a tool or in a locked control cabinet (both protection rating IP 54 or higher) as an enclosure in accordance with EN61010-1.

4.2 Installation of the device

- Mount the device on a 35 mm DIN rail.

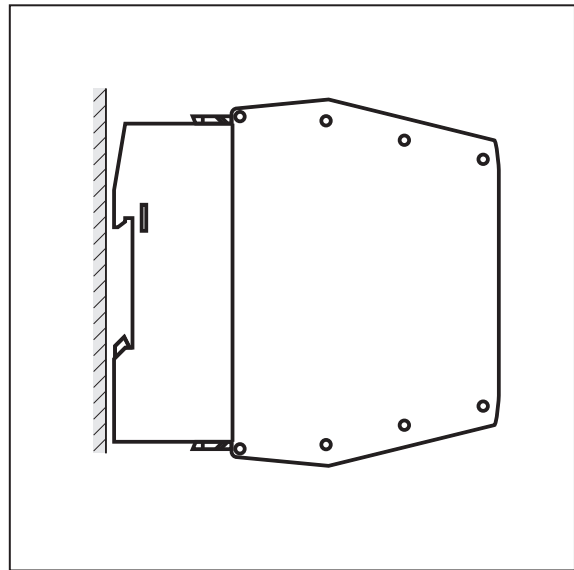
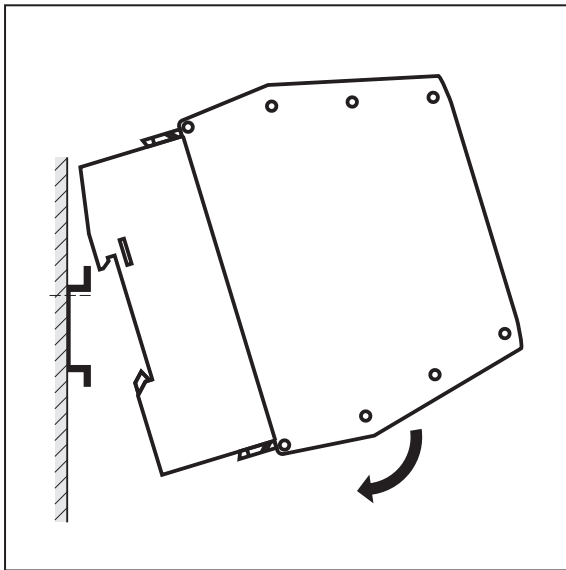

- Leave enough space (≥ 50 mm) between the device and the top and bottom of the control cabinet to enable air circulation and to avoid excessive heating.

4.3 Identical devices mounted side by side

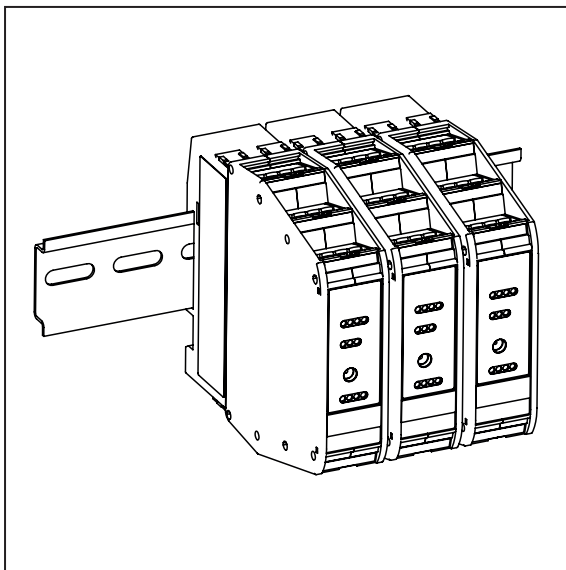

Fig. 1: Identical devices mounted side by side (25 mm)

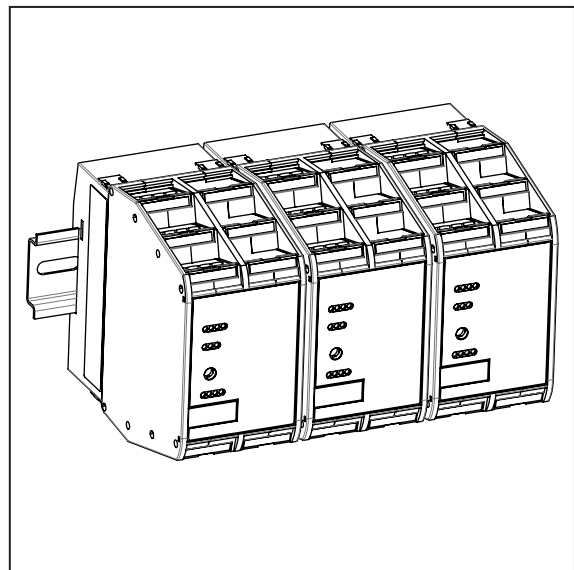
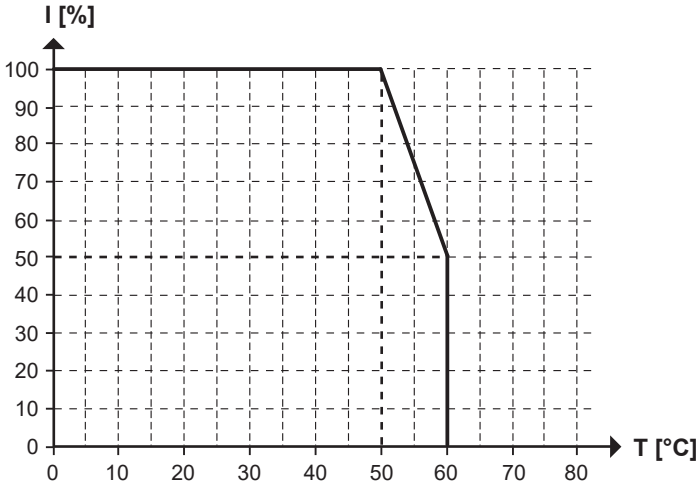

Fig. 2: Identical devices mounted side by side (50 mm)

4.4 Deratings for side by side mounting of identical devices

When identical devices are mounted next to each other, derating according to the following table applies:

Article number	Derating
AC2258	<p>Overall current rating of inputs and outputs when mounted side by side</p>  <p>Ambient temperature -25...60°C / linear derating 50...60°C Overall current rating for the inputs and outputs 50% at 60°C corresponds to a sensor current of 100 mA and 2 x 6 A or 4 x 3 A (example outputs)</p>

4.5 Side by side mounting of different devices

ATTENTION

If units are mounted side by side, inadmissible heating may occur between the units.

- ▷ Malfunction / damage is possible.
- ▶ Take into account the internal heating of all devices when mounting different devices side by side and observe the environmental conditions for each device.

4.6 Removing the device

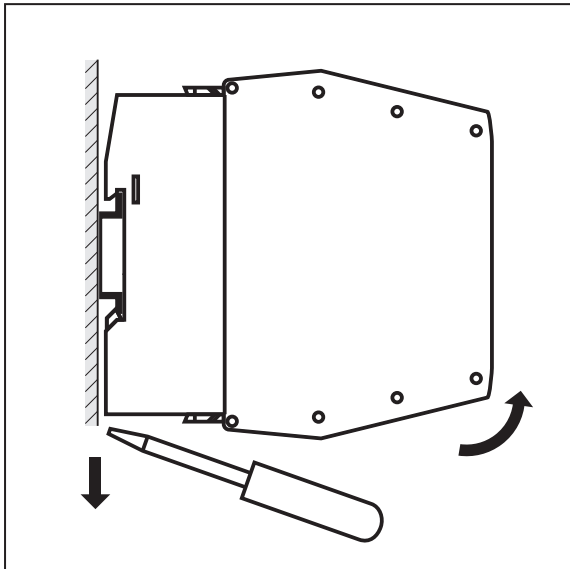



4.7 Installation of the sensors

- ▶ Follow the manufacturer's installation instructions.

5 Electrical connection

5.1 General wiring information

-  ▶ Disconnect the device from the mains supply before installation; if necessary, also disconnect any independently supplied input / output load circuits.
- ▶ Observe the national and international regulations for the installation of electrical equipment.
-  AS-i / AUX only permissible as SELV / PELV.
-  Do not connect the terminals I1...I4 and I+, I- to external potential.



WARNING

Use of unconnected terminals

- ▷ Electric shock possible.
- ▶ Do not use unconnected terminals (n.c) which are not shown in the drawing as support point terminals.
- ▷ Protection guaranteed.

Accessible surfaces of the device are insulated to the AS-i / AUX circuits and to the relay circuits O1...O4 (AC2258) or to the relay circuits O1...O2 (AC2256) with basic insulation according to IEC 61010-1 (mains circuit of overvoltage category II up to 300 V nominal mains voltage).

This does not apply to connection areas and cooling openings (IP20).

The AS-i / AUX circuits are insulated from each other with basic insulation according to IEC 61010-1 (secondary circuit with max. 32 V DC, supplied from the mains circuit up to 300 V of overvoltage category II).

The relay circuits O1...O4 (AC2258) or O1...O2 (AC2256) are insulated from AS-i / AUX and from each other with reinforced insulation according to IEC 61010-1 (mains circuit of overvoltage category II up to 300 V nominal mains voltage).

The external wiring has to be carried out in a way that ensures the required separation from other circuits.

5.2 Wiring

5.2.1 Digital input and output module AC2256

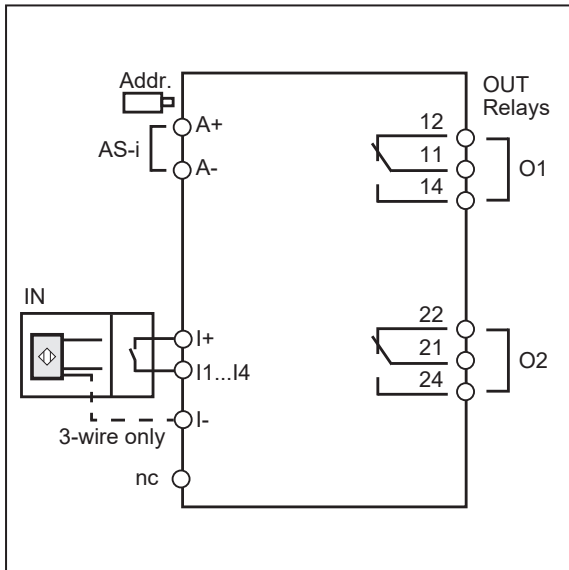

Fig. 3: Wiring

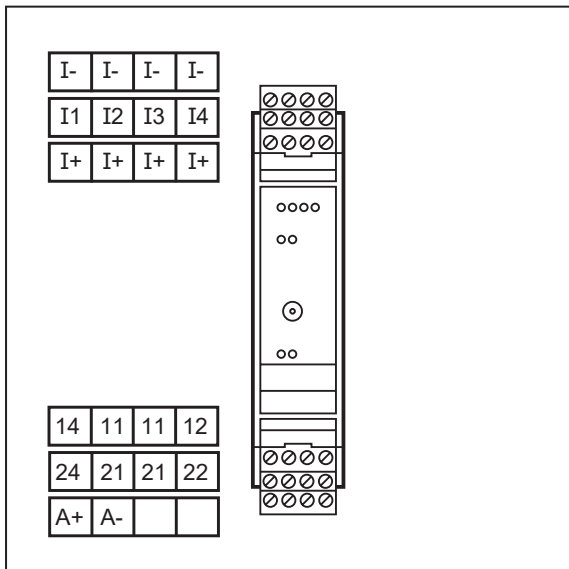

Fig. 4: Terminal connection

- I-: sensor supply 0 V
- I+: sensor supply +24 V
- I1...I4: switching input sensor 1...4,
sensor supply from AS-i
- A+: AS-i +
- A-: AS-i -
- O1...O2: switching output relays 1...2
- 11: relay O1 changeover contact, common
- 12: relay O1 changeover contact, normally closed
- 14: relay O1 changeover contact, normally open
- 21: relay O2 changeover contact, common
- 22: relay O2 changeover contact, normally closed
- 24: relay O2 changeover contact, normally open
- nc: not connected

5.2.2 Digital input and output module AC2258

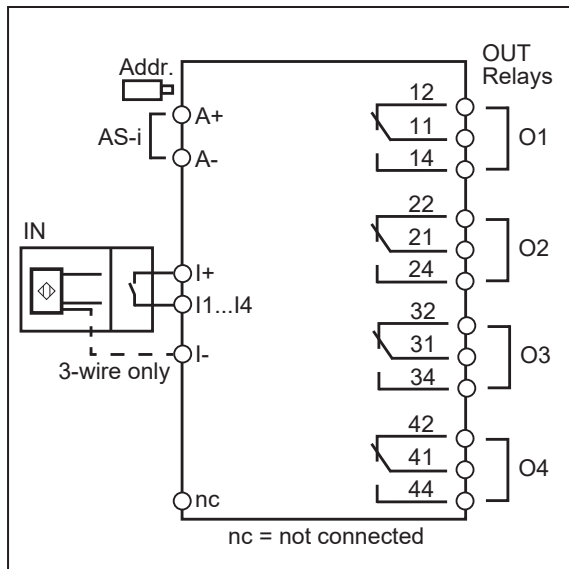

Fig. 5: Wiring

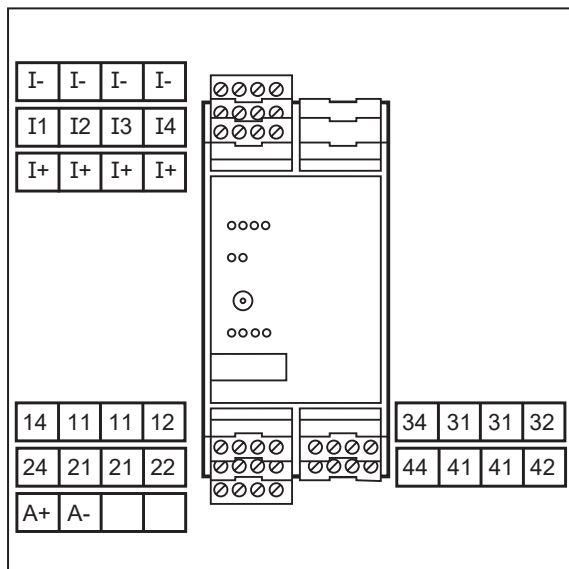





Fig. 6: Terminal connection

I-:	sensor supply 0 V
I+:	sensor supply +24 V
I1...I4:	switching input sensor 1...4, sensor supply from AS-i
A+:	AS-i +
A-:	AS-i -
O1...O4:	switching output relays 1...4
11:	relay O1 changeover contact, common
12:	relay O1 changeover contact, normally closed
14:	relay O1 changeover contact, normally open
21:	relay O2 changeover contact, common
22:	relay O2 changeover contact, normally closed
24:	relay O2 changeover contact, normally open
31:	relay O3 changeover contact, common
32:	relay O3 changeover contact, normally closed
34:	relay O3 changeover contact, normally open
41:	relay O4 changeover contact, common
42:	relay O4 changeover contact, normally closed
44:	relay O4 changeover contact, normally open
nc:	not connected

5.3 Safety instructions relay connections

-  The external protection of the relay currents according to the valid regulations to the values of the technical data is the responsibility of the system manufacturer.
-  The relays are not designed for small switching currents. If the relay outputs are used for switching very small currents (e.g. PLC inputs), considerable contact resistance can arise.
-  External interference suppression of inductive loads is required.

5.4 Connection technology

ATTENTION

No IP 20 protection without connector.

- ▷ Cover unused connectors with terminals.
 - ▶ Observe IP 20.
-

5.5 Connection accessories

The device is supplied without connector.

6 Set-up / addressing

The address is set to 0 at the factory.

6.1 Addressing with the AC1154 addressing unit

When mounted and wired, the module can be addressed with the addressing cable (E70213) via the integrated addressing interface.

If a slave is used in combination with a master of the new generation (version 2.1), it is possible to select an address between 1A and 31B with the AC1154 addressing unit.

If a slave with the ID code "A" (extended address mode possible) is used in combination with a master of the 1st generation (version 2.0), the parameter P3 must be 1 and the output bit D3 must be 0.* The output bit D3 must not be used.

An address between 1A and 31A must be assigned to this slave.

* Default setting

7 Operating and display elements

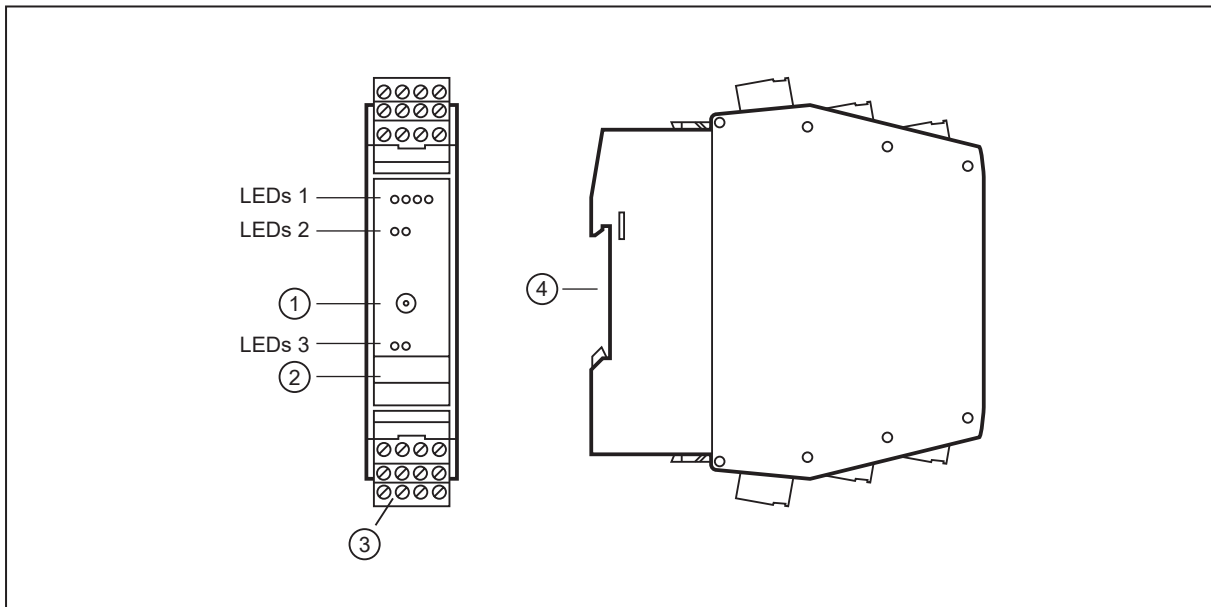

Fig. 7: LED assignment AC2256

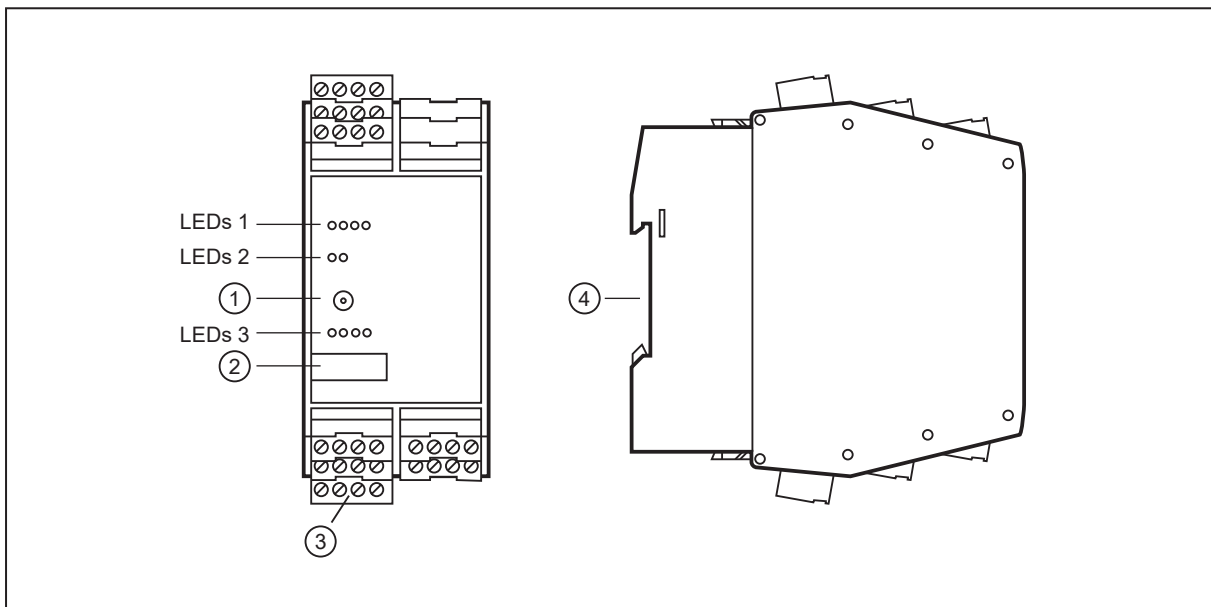

Fig. 8: LED assignment AC2258

1: Addressing socket	LEDs 1: switching status indication sensor inputs I1...I4
2: Panel for labelling	LEDs 2: AS-i, FAULT
3: Connector with screw terminals	LEDs 3: switching status indication relay outputs O1...O4 (AC2258) / O1...O2 (AC2256)
4: DIN rail mounting	

7.1 Operation / LEDs

LED 1 yellow on:	Input (I1...I4) switched
LED 2 AS-i green on:	AS-i voltage supply OK

LED 2 FAULT red on:	AS-i communication error, slave does not participate in the "normal" exchange of data, e.g. slave address 0
LED 2 FAULT red flashes:	Peripheral fault, e.g. sensor supply / output overloaded or shorted
LED 3 yellow on:	Relay output (O1...O4) / (O1...O2) switched

7.2 Scale drawing

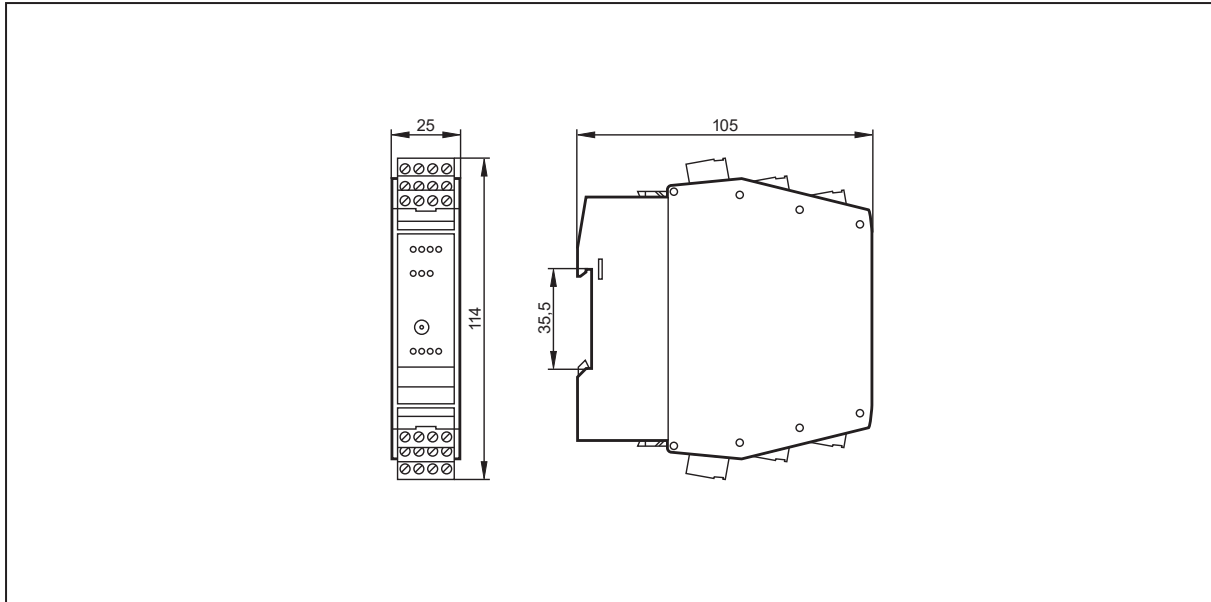

Fig. 9: AC2256

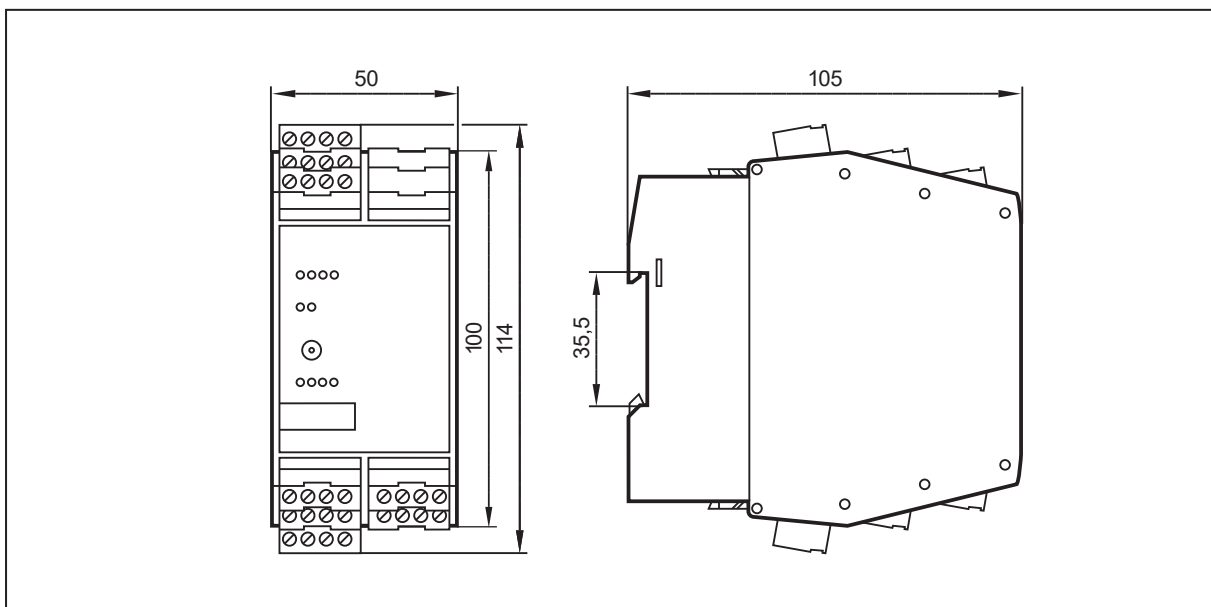

Fig. 10: AC2258

8 Maintenance, repair and disposal

8.1 Maintenance

The unit is maintenance-free.

8.2 Cleaning the housing surface

- ▶ Disconnect the device.
- ▶ Clean the device from dirt using a soft, chemically untreated and dry cloth.



Micro-fibre cloths without chemical additives are recommended.

8.3 Repair

- ▶ The device must only be repaired by the manufacturer. Observe the safety instructions (→ 2 Safety instructions) .

8.4 Disposal

- ▶ Dispose of the unit in accordance with the national environmental regulations.