

ifm electronic



Operating instructions

AS interface

AS-i AirBox

AC528A

UK

7390767 / 00 01 / 2009



Contents

1	Safety instructions	3
2	Functions and features	3
3	Operating and display elements	4
4	Assembly	5
5	Addressing	9
5.1	Addressing with the AC1144 addressing unit	9
6	Electrical connection.....	10
7	Pneumatics	11
7.1	Compressed air	11
7.1.1	Removal of the tubes	11
7.1.2	Manual override	11
7.2	Specification of the compressed air purity.....	11
8	Electromagnetic compatibility (EMC).....	12
9	Operation	13
10	Maintenance / repair	14
11	Technical data	14



Observe the instructions for the safe use in hazardous areas: → Operating instructions (Ex protection related part) for AS-i modules according to EU directive 94/9/EC annex VIII (ATEX) group II, equipment category 3D.

If no operating instructions (Ex protection related part) or EC declaration of conformity is supplied with this product in the language of the EU user country, these can be requested from your dealer (see delivery note) or manufacturer (see cover sheet / back).

1 Safety instructions

- Please read the product description prior to set-up of the unit. Ensure that the product is suitable for your application without any restrictions.
- The unit conforms to the relevant regulations and EC directives.
- Improper or non-intended use may lead to malfunctions of the unit or to unwanted effects in your application.

That is why installation, electrical connection, set-up, operation and maintenance of the unit must only be carried out by qualified personnel authorised by the machine operator.

2 Functions and features

- maximum number of modules per master: 62
- AS-interface version 3.0, downward compatible
- connection to the pneumatic system via tube fitting, outside calibration according to CETOP standards RP 54 P
- operating pressure range 2...8 bar

Operation outside the indicated operating pressure range or use of incorrectly processed compressed air can cause permanent leaks and irreparable damage to the pneumatic components and may lead to malfunctioning.

3 Operating and display elements

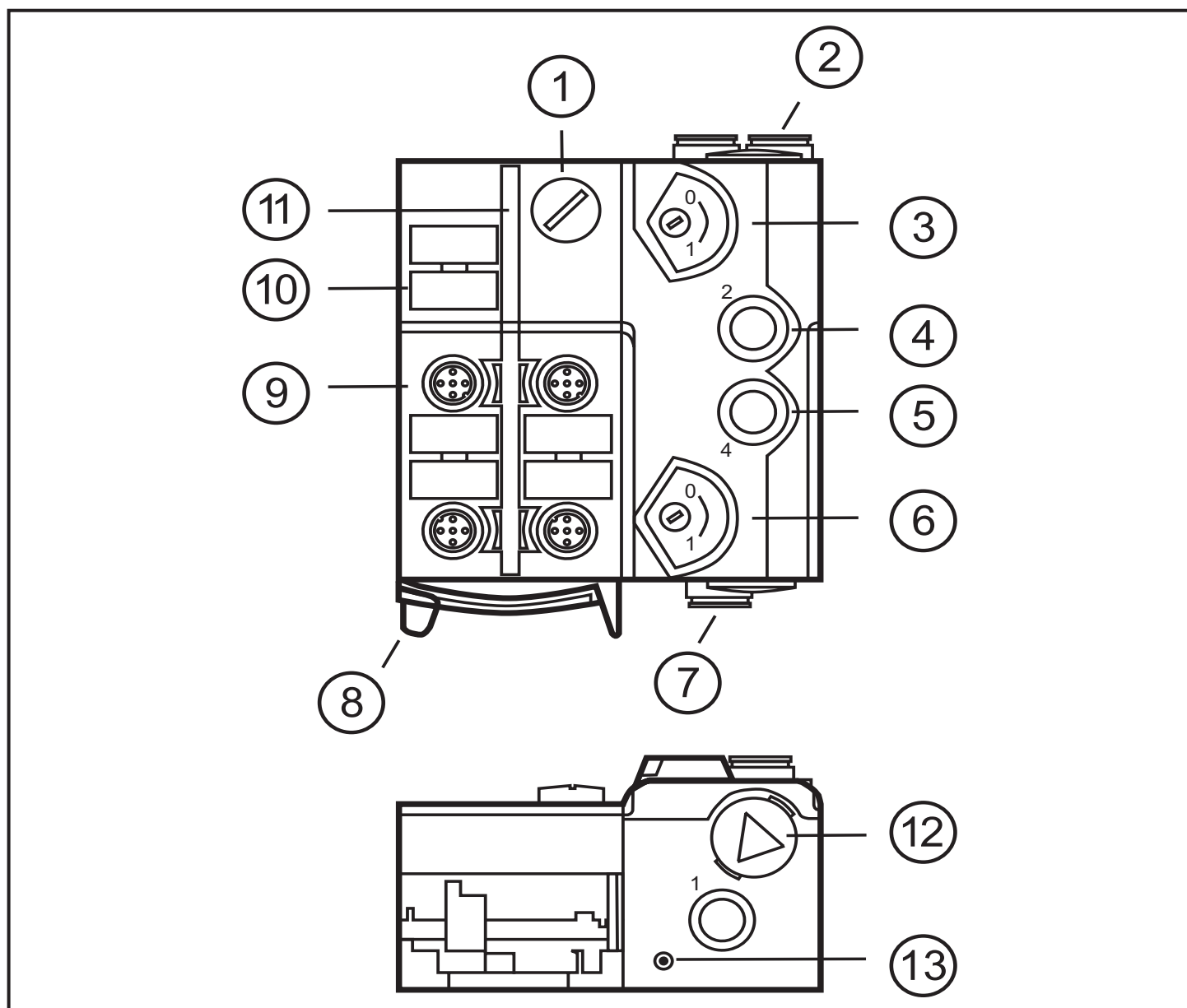

1: addressing interface

2: exhaust air [3,5]

3: manual override

4: operating connection [2]

5: operating connectio [4]

6: manual override

7: compressed air [1]

8: locking/unlocking

9: 4 M12 sockets

10: labels

11: LED

12:/13: parts without function. Do not open, do not actuate. Risk of destruction.

4 Assembly

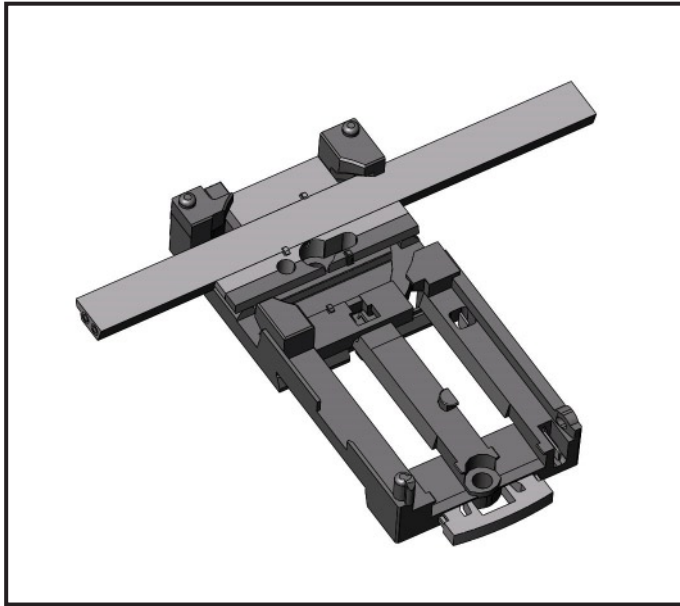

Orientation of the flat cable on delivery

Carefully place the yellow AS-i flat cable into the profile slot.

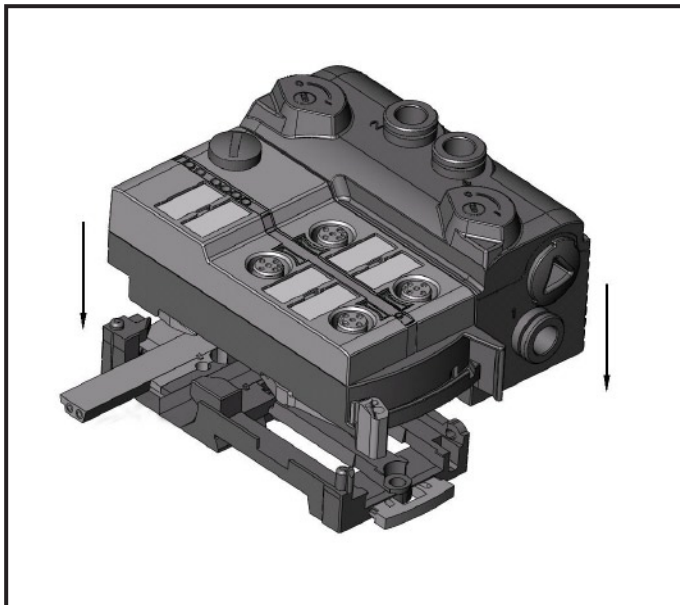

Mount the upper part.



Lock the unit.

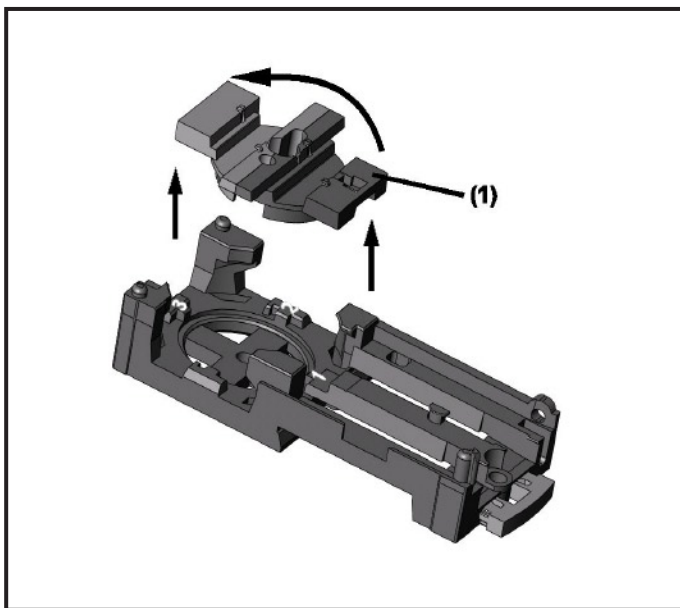

With the supplied lower part the flat cable can be aligned in three directions.

For the requested direction place the flat cable guide (1) accordingly.

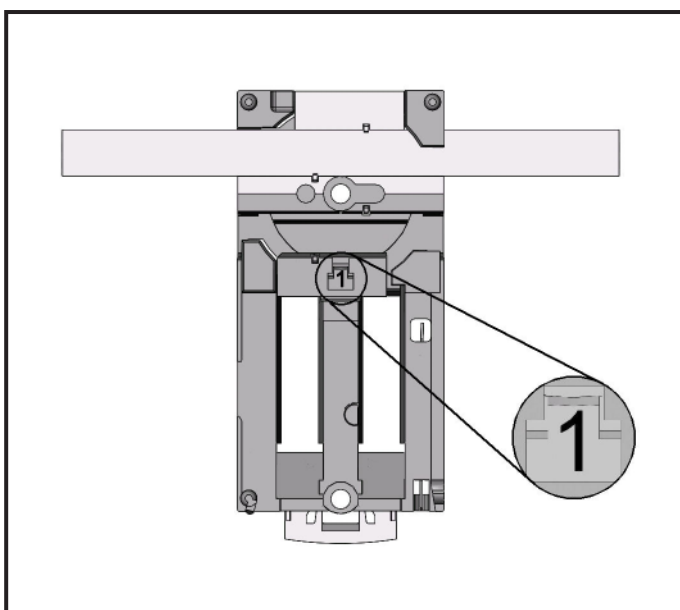
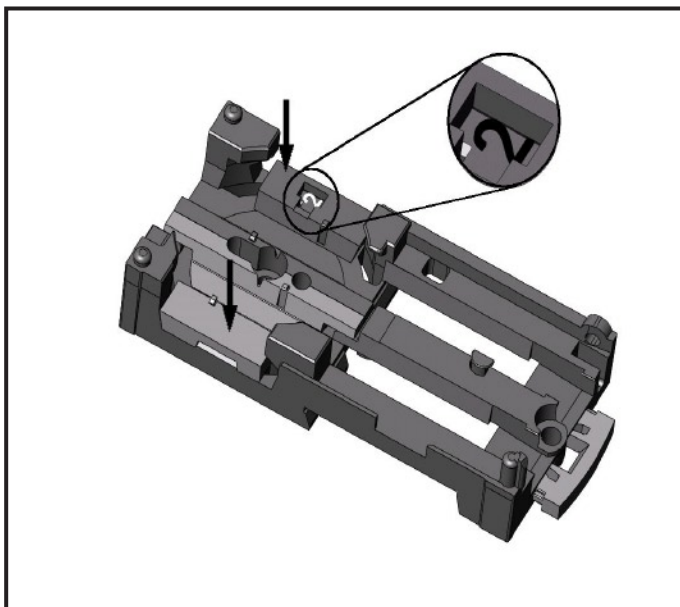

Settings at the lower part

Select the position 1, 2 or 3 depending on the requested flat cable alignment (®).

A = Factory setting

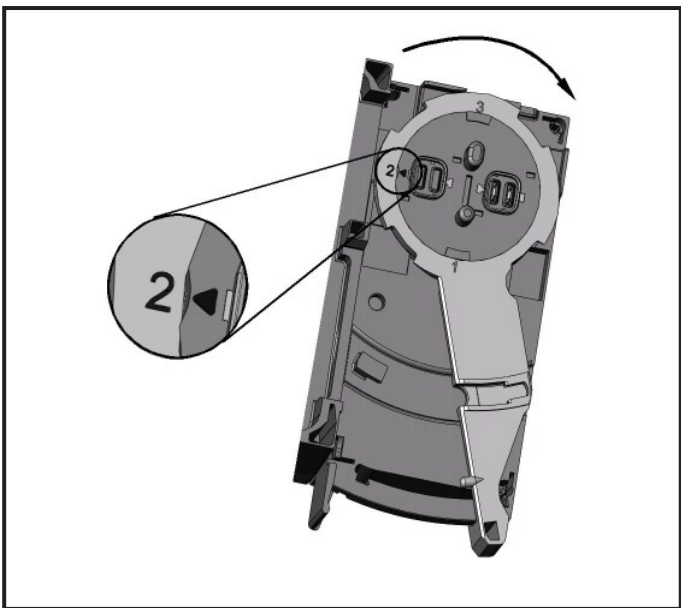
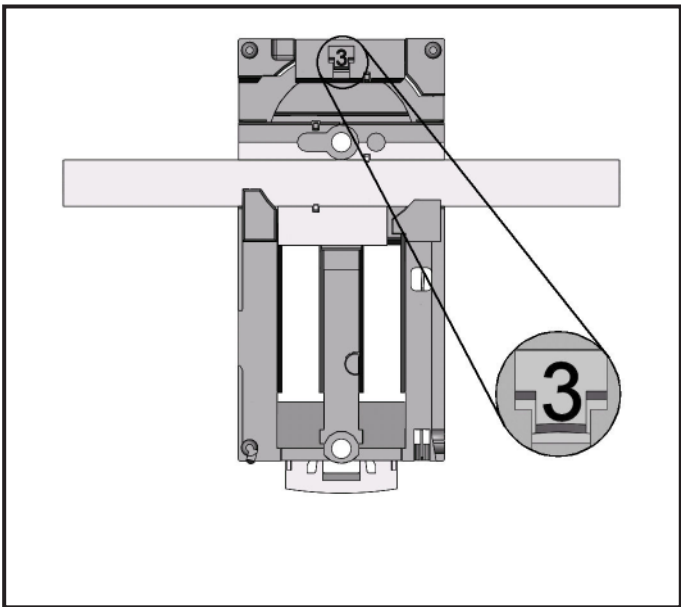
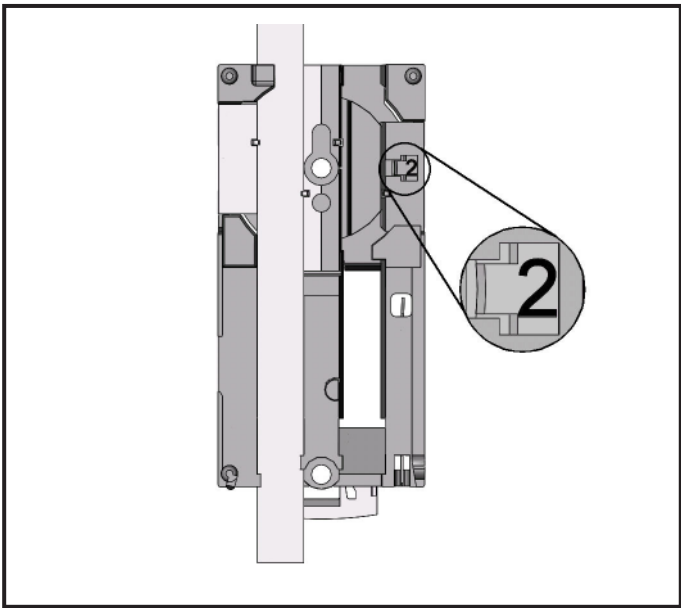

Settings at the upper part

Then set the selected position at the upper part. To do so, turn the arrow to the corresponding number (figure D1 and D2).

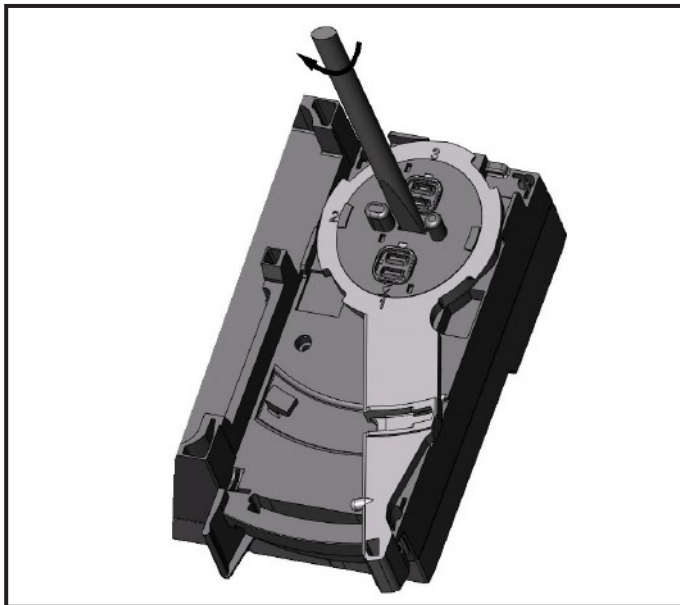

Use a tool, e.g. a screwdriver (figure D1) or the yellow / black flat cable guide (figure D2).

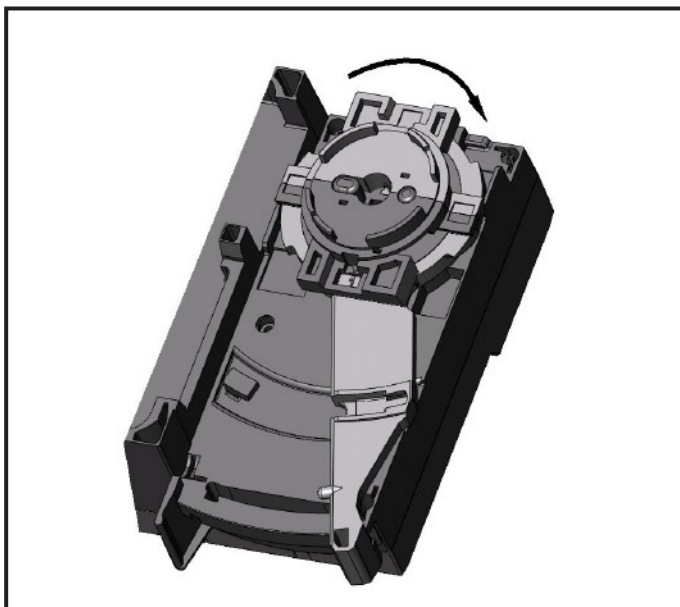

Open the unit

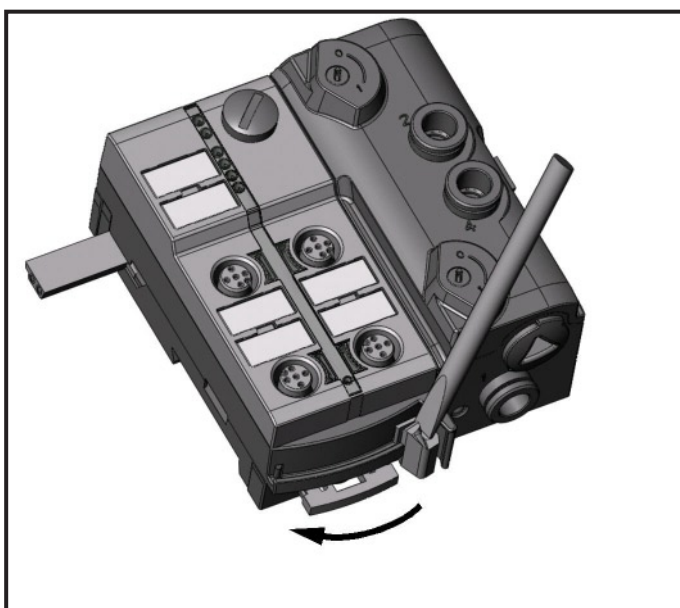

Open the unit using a tool as shown (e.g. screwdriver).

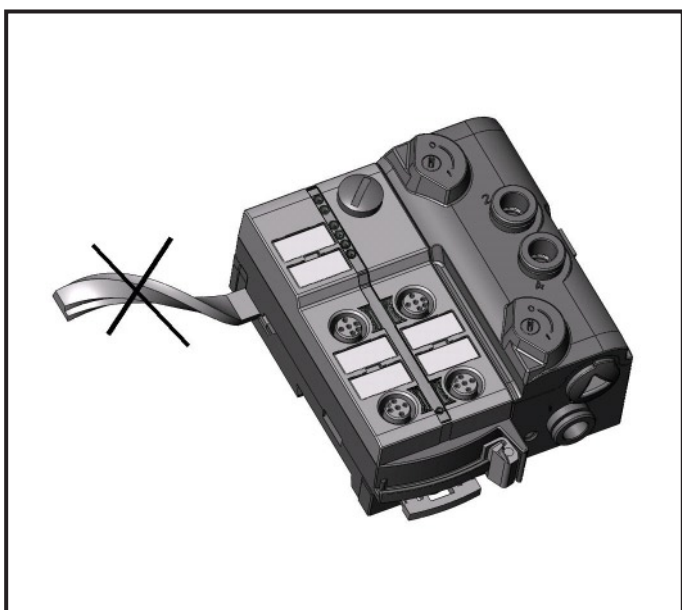

Take care in laying the AS-i flat cable, the flat cable should be laid straight for about 15 cm.

5 Addressing

At the factory the address is set to 0.

5.1 Addressing with the AC1144 addressing unit

When mounted and wired the module can be addressed with the addressing cable (E70213) via the implemented addressing interface.

If a slave with the extended addressing mode is used in combination with a master of the first generation (version 2.0), the parameter P3 must be 1 and the output bit D3 must be 0*. The output bit D3 and the parameter bit P3 must not be used.

* Default setting

If a slave with the extended addressing mode is used in combination with a master of the first generation (version 2.0), an address between 1A and 31A must be assigned to this slave.

6 Electrical connection

Connect the plugs of the sensors / actuators to the M12 sockets. Cover the unused sockets with protective caps (E73004)*, the addressing socket with the supplied protective cap. Tightening torque 0.8 Nm.

The flat cable end seal (E70413)* must be used if the module is at the end of the cable line. * to be ordered separately

AC528A

4 inputs / 2 pneumatic outputs

AS-i profile S-7.A.E / extended addressing mode: yes

Data bit	D0		D1		D2		D3	
Input	1		2		3		4	
Socket	I1/2		I1/2	I2	I3/4		I3/4	I4
Pin	4		2	4	4		2	4
Pneumatic output	2		4		-		-	

Inputs (Y-circuit)

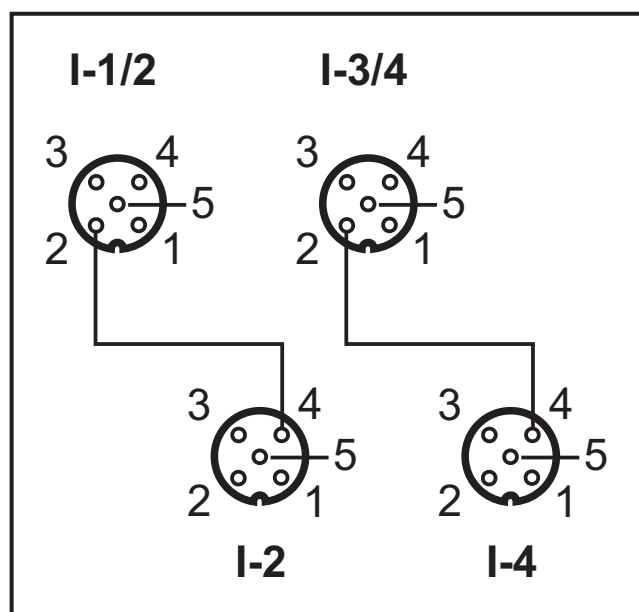

7 Pneumatics

Circuit diagram pneumatics 2x 3/2-way valve

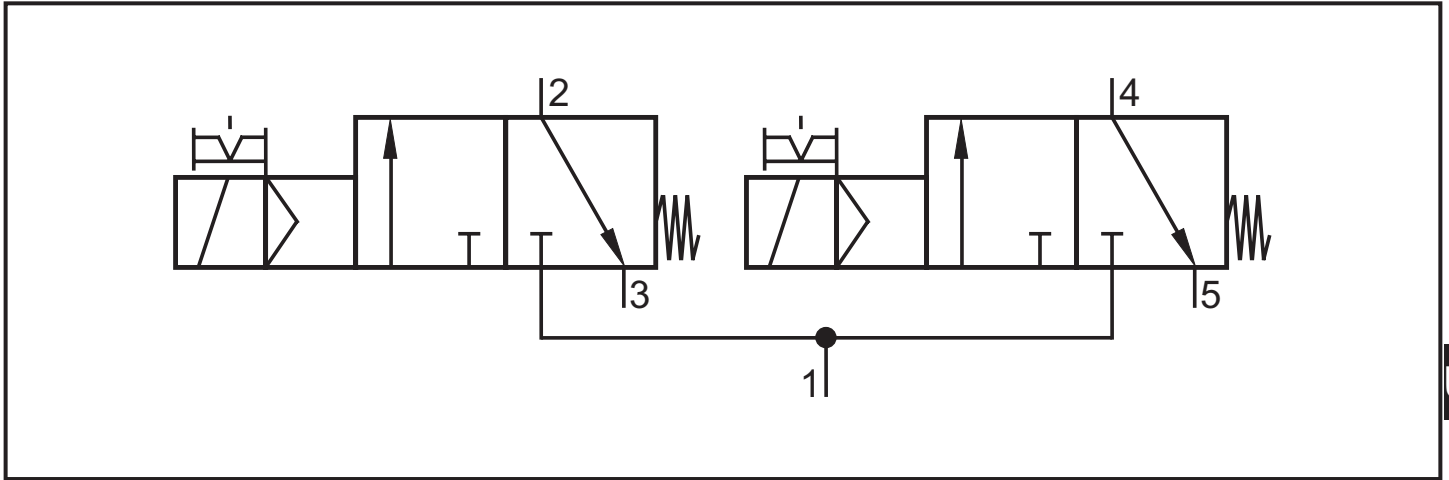

UK

7.1 Compressed air

Adhere to the safety regulations and provisions for the installation of pneumatic systems. Switch off pressure. Connect the compressed air supply 1, the operating connections 2 and 4 and if necessary the exhaust 3 and 5 to the pneumatic system. Cut the connection tube straight and push it into the tube fitting.

7.1.1 Removal of the tubes

To remove the tube push the grey clamping ring and pull out the tube at the same time.

7.1.2 Manual override

The pneumatic output can be activated manually using the manual override (pressing/releasing or pressing/turning/locking).

For trouble-free operation sufficiently treated air must be used.



The electrical triggering has priority over the mechanical triggering.

7.2 Specification of the compressed air purity

According to ISO 8573-1: 2001 the air purity is divided into three classes:

1. The purity class of the solid particle content
2. The purity class for the humidity content
3. The purity class for the total oil content

The AirBoxes are suitable for non-lubricated compressed air of the purity classes 6- 3- 1 and for lubricated compressed air of the purity classes 6-3-4.

Meaning:

1. Solid particle contamination according to class 6:
Max. particle size 5 μm , max. particle density 5 mg / m^3
2. Maximum water content according to class 3:
Pressure dew point $-20\text{ }^\circ\text{C}$
3. Maximum total oil content according to class 1:
for non-lubricated compressed air 0.01 mg / m^3
Maximum total oil content according to class 4:
for lubricated compressed air $< 5\text{ mg} / \text{m}^3$, this corresponds to approx. 1 oil drop / 4000 litres of air

Once the AirBox has been operated with lubricated air, it always has to be operated with lubricated air as the oil removes the initial lubrication.

8 Electromagnetic compatibility (EMC)

The AirBox is rated for operation in industrial environments. The test of the electrostatic discharge was carried out in accordance with EN 61000-4-2 with the following test levels:

- contact discharge $\pm 4\text{ kV}$
- air discharge $\pm 8\text{ kV}$

Special applications such as the conveying and distribution of bulk material can generate higher electrostatic charges. To avoid electrostatic discharge the following remedial actions are possible, among others:

- Equalisation of potential according to the installation instructions
- Separate laying of
 - signal and bus cables
 - equipotential bonding conductors
 - power cables
- Physical separation of the AirBox and all cables from all parts carrying or discharging electrostatic charges

If these discharges are not avoided there is the danger of:

- injury to / incapacitation of operators and maintenance staff
- spark formation
- damage to the AirBox

- damage to the electrical equipment

9 Operation

Avoid build-up of dirt and dust on the upper and lower parts so that the locking mechanism is not affected.

Check the reliable functioning of the unit. Display by LEDs:

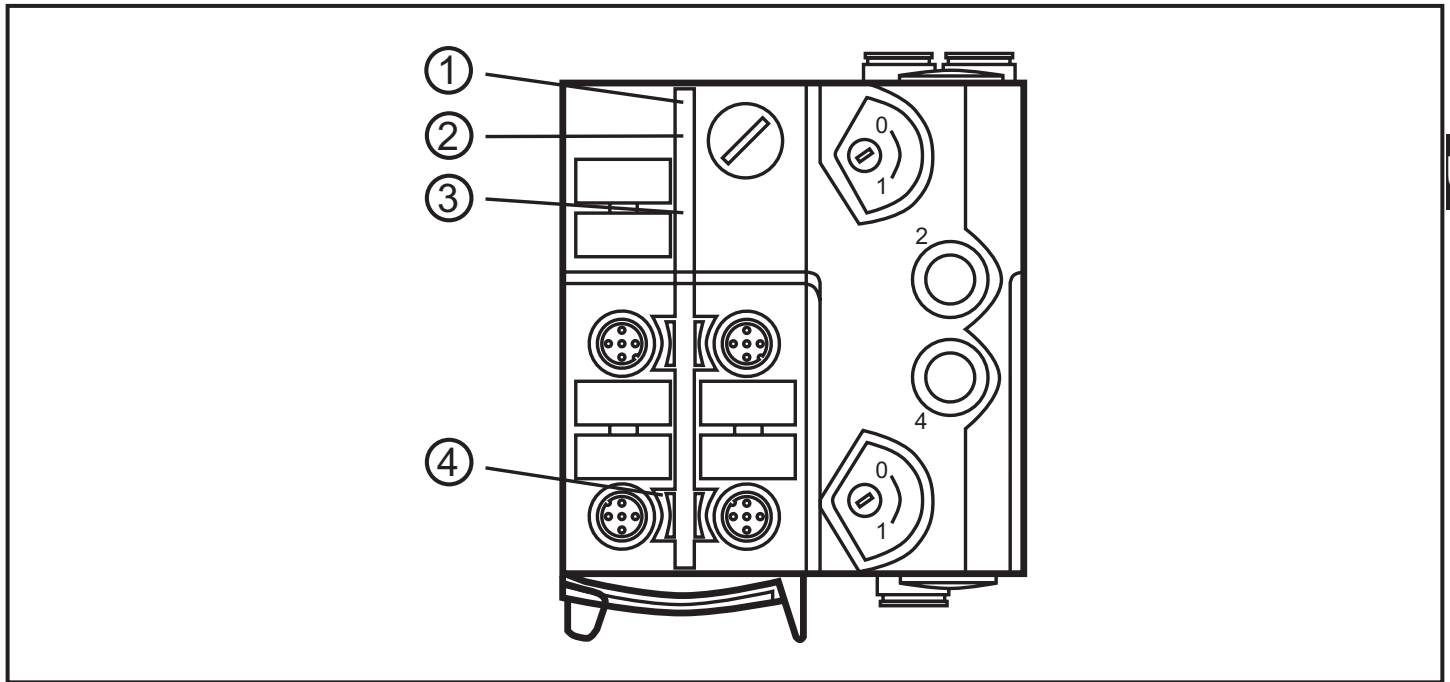

1: LED PWR

2: LED FAULT

3: LED 1

4: LED 2

- LED 2 yellow: input switched
- LED PWR green: AS-i voltage supply ok
- LED FAULT red lights: AS-i communication error, slave does not participate in the „normal“ exchange of data, e.g. slave address 0
- LED FAULT red flashing: peripheral fault, e.g. overload or short circuit of the sensor supply

Important note to LED 1

LED 1 yellow

Only indicates the logic state of the PLC outputs. The pneumatic output status does not necessarily correspond to the indicated status of LED 1. The pneumatic output status is not indicated on the unit.

10 Maintenance / repair

The unit must not be modified nor can it be repaired. In case of a fault please contact the manufacturer.

11 Technical data

Technical data and further information at
www.ifm.com --> Select your country --> Data sheet direct