

ifm electronic



Operating instructions  
ClassicLine module

**AS interface**

**AC5234**

**UK**

80222440/00 08/2014

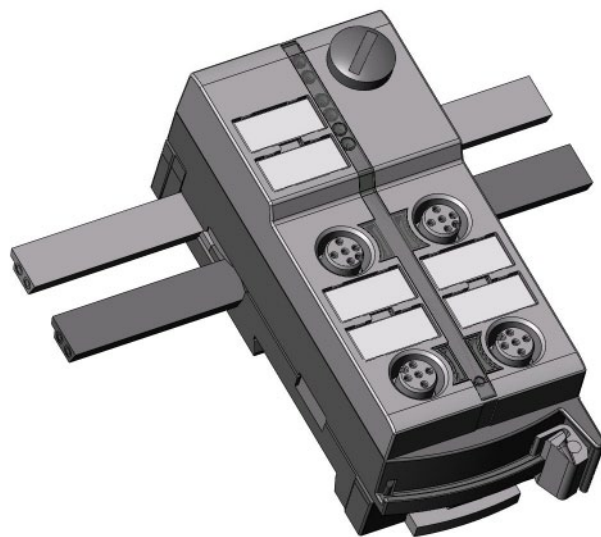

# Contents

1 Preliminary note.....	3
2 Safety instructions .....	3
3 Functions and features .....	3
4 Installation.....	4
5 Operating and display elements .....	9
6 Addressing.....	9
6.1 Addressing with the AC1154 addressing unit.....	9
7 Electrical connection.....	10
8 Operation.....	11
9 Technical data.....	11

# 1 Preliminary note

- An instruction is indicated by „►“:  
Example: ► Mount the unit as shown.
- A reaction to the action is indicated by „>“:  
Example: > yellow LED lights.



Important note

Non-compliance can result in malfunction or interference.



Information

Supplementary note.

UK

## 2 Safety instructions

- Please read the operating instructions prior to set-up of the device. Ensure that the product is suitable for your application without any restrictions.
- The unit conforms to the relevant regulations and EC directives.
- Improper or non-intended use may lead to malfunctions of the unit or to unwanted effects in your application.
- Installation, electrical connection, set-up, operation and maintenance of the unit must only be carried out by qualified personnel authorised by the machine operator.

## 3 Functions and features

- maximum number of modules per master: 62
- AS-interface version 3.0, downward compatible

## 4 Installation



▶ Disconnect the system from power before installation.

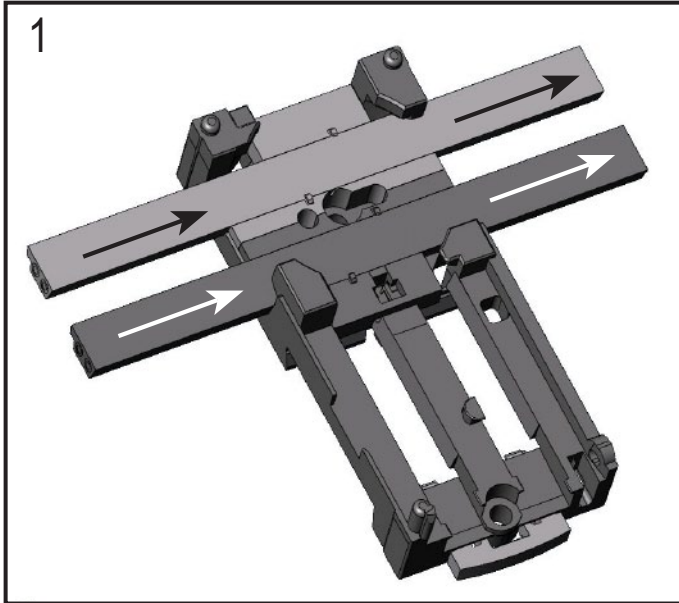

### Alignment of the flat cable on delivery

Carefully place the yellow and optionally the black AS-i flat cable into the profile slot.

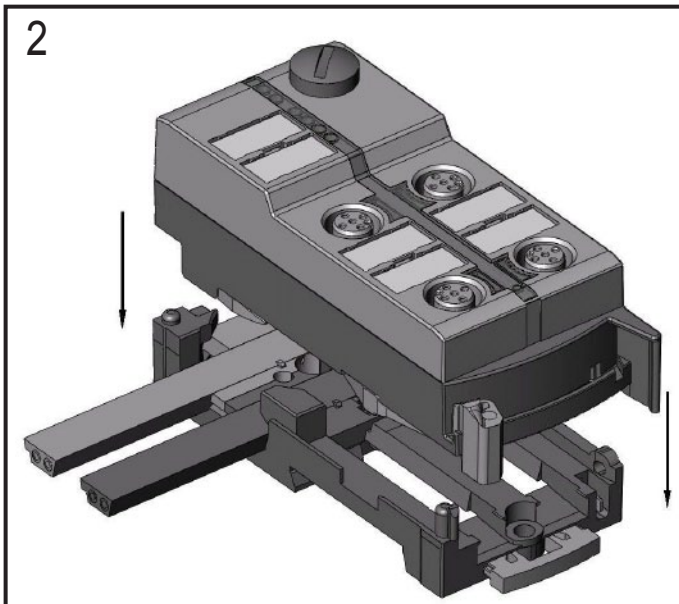

Mount the upper part.

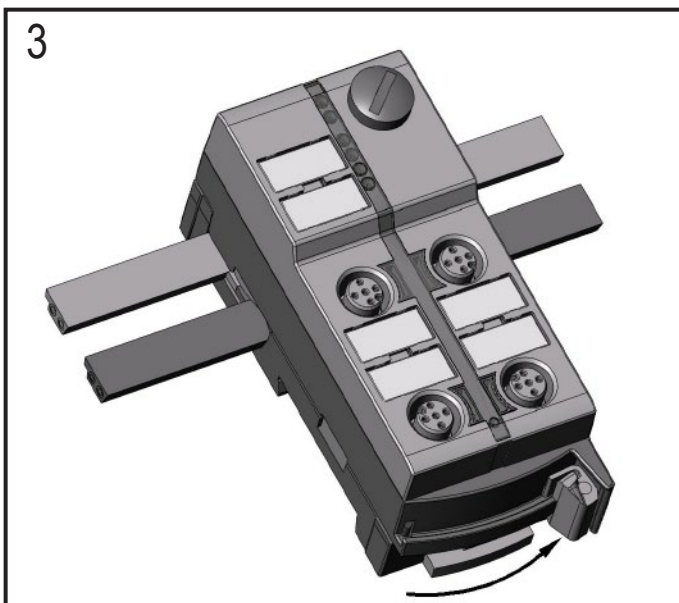

Lock the unit.

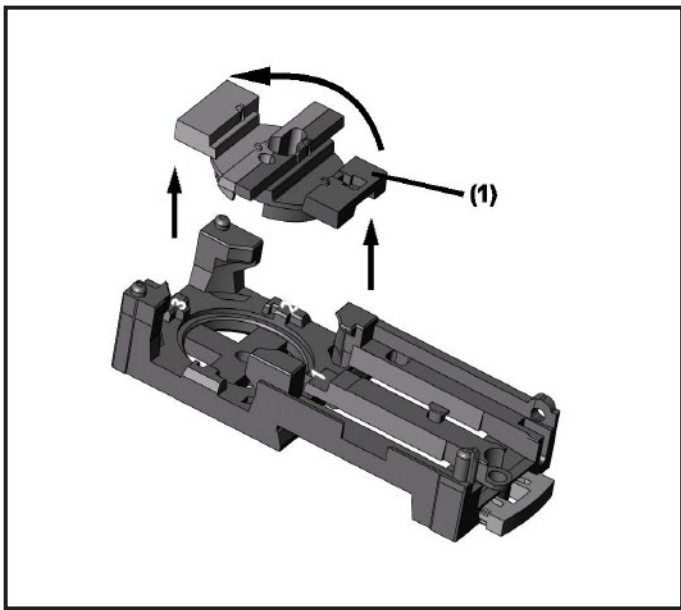

With the supplied lower part the flat cable can be aligned in three directions.

For the requested direction place the flat cable guide (1) accordingly.

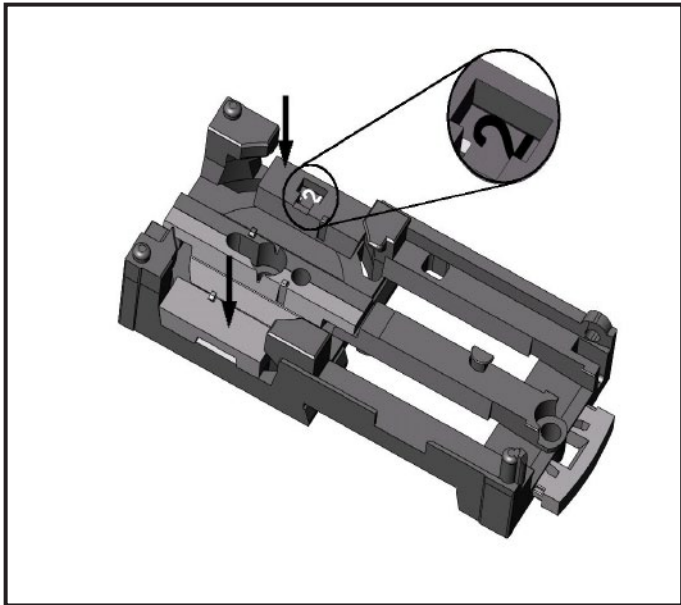

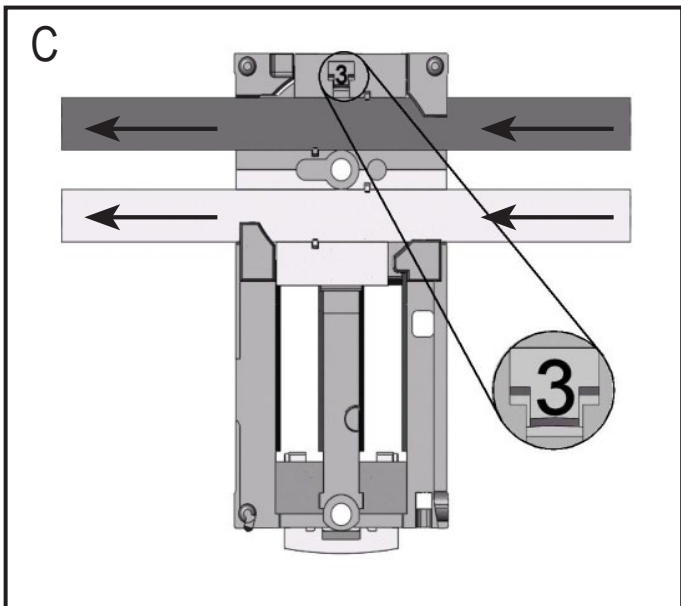
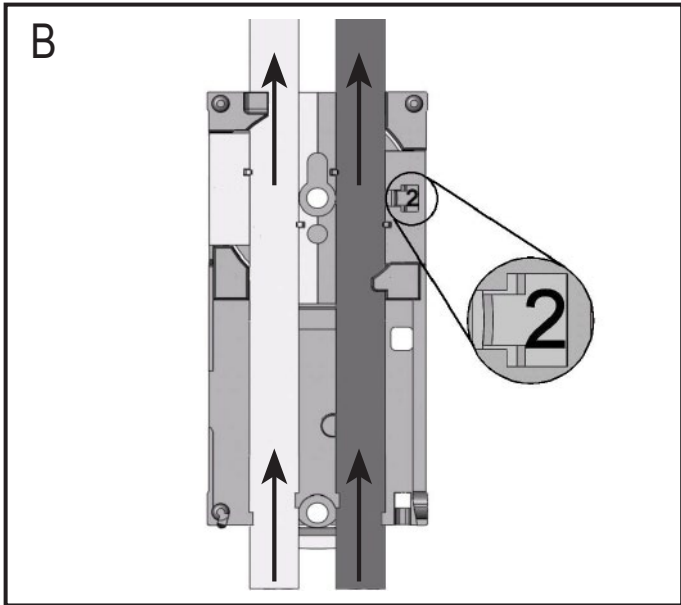
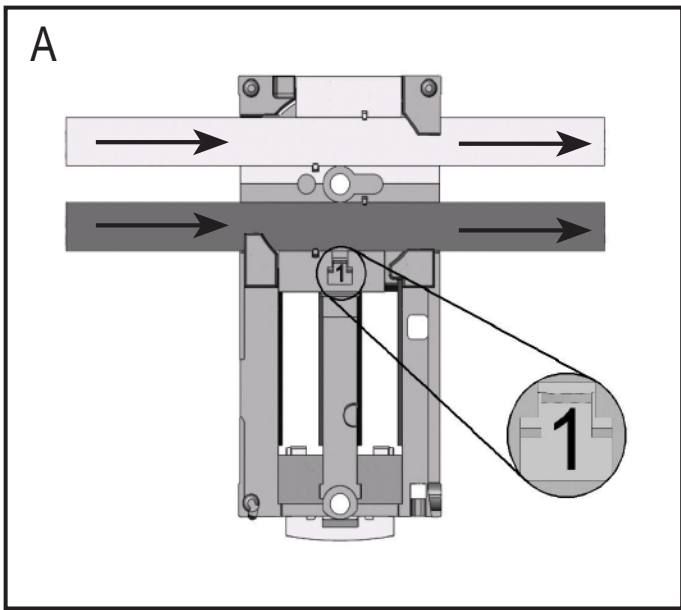

## Settings at the lower part

Select the position 1, 2 or 3 depending on the requested flat cable alignment (→).

A = factory setting

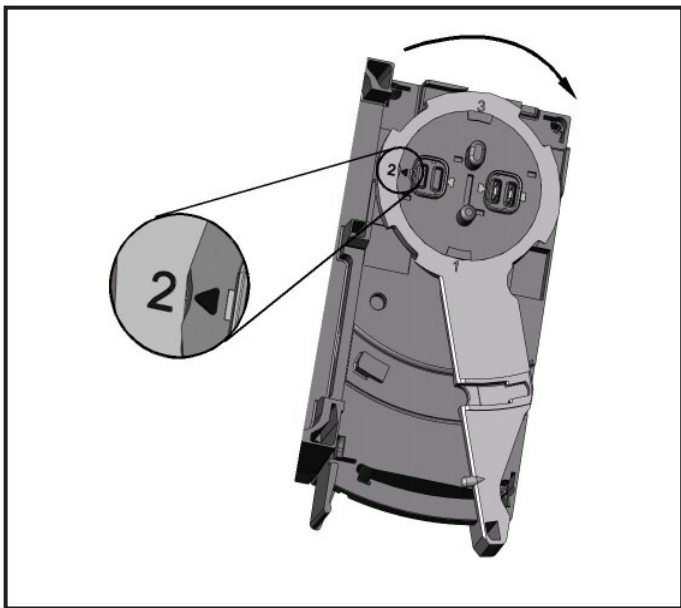

## Settings at the upper part

Then set the selected position at the upper part. To do so, turn the triangle to the corresponding number (fig. D1 and D2).

UK

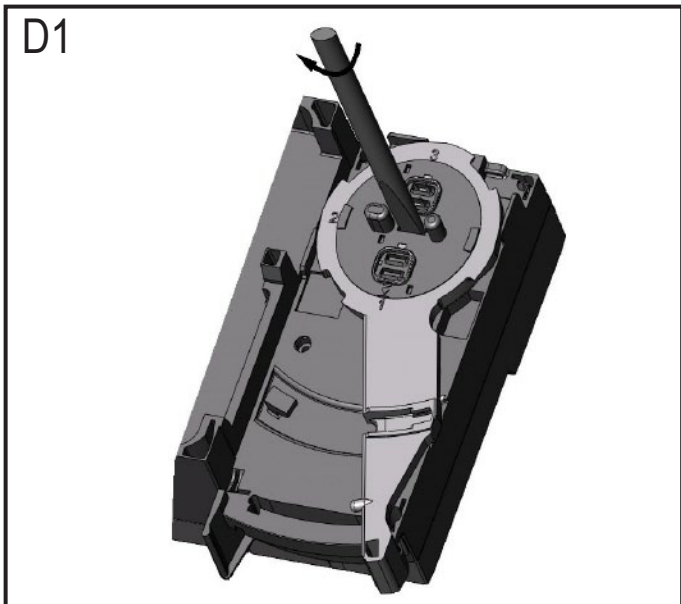

Use a tool, e.g. a screwdriver (figure D1) or the yellow / black flat cable guide (figure D2).

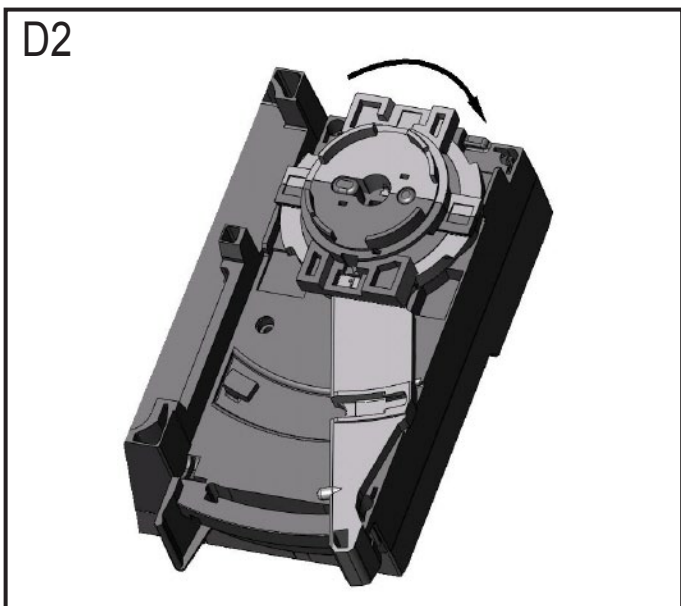

## Open the unit



Open the unit using a tool as shown (e.g. screwdriver).

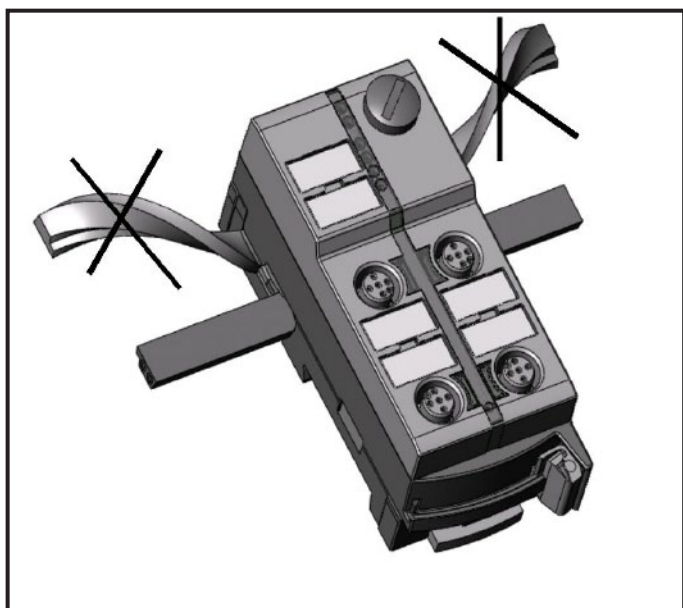
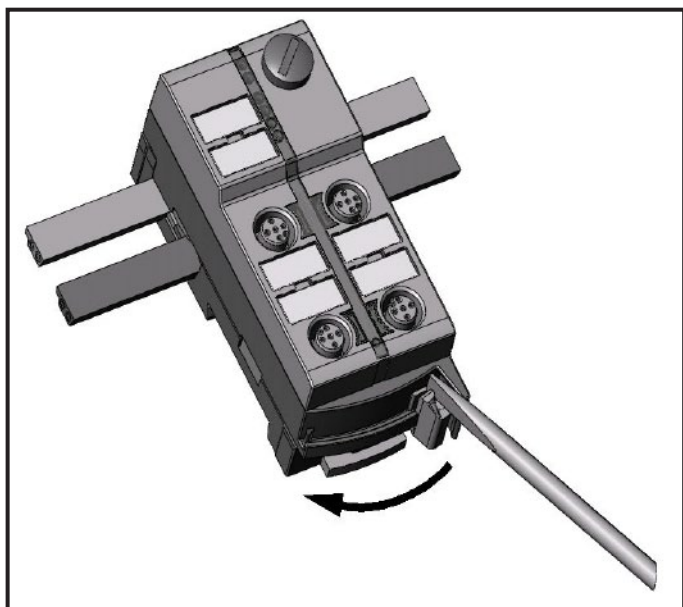

Take care in laying the AS-i flat cable, the flat cable should be laid straight for about 15 cm.



## 5 Operating and display elements

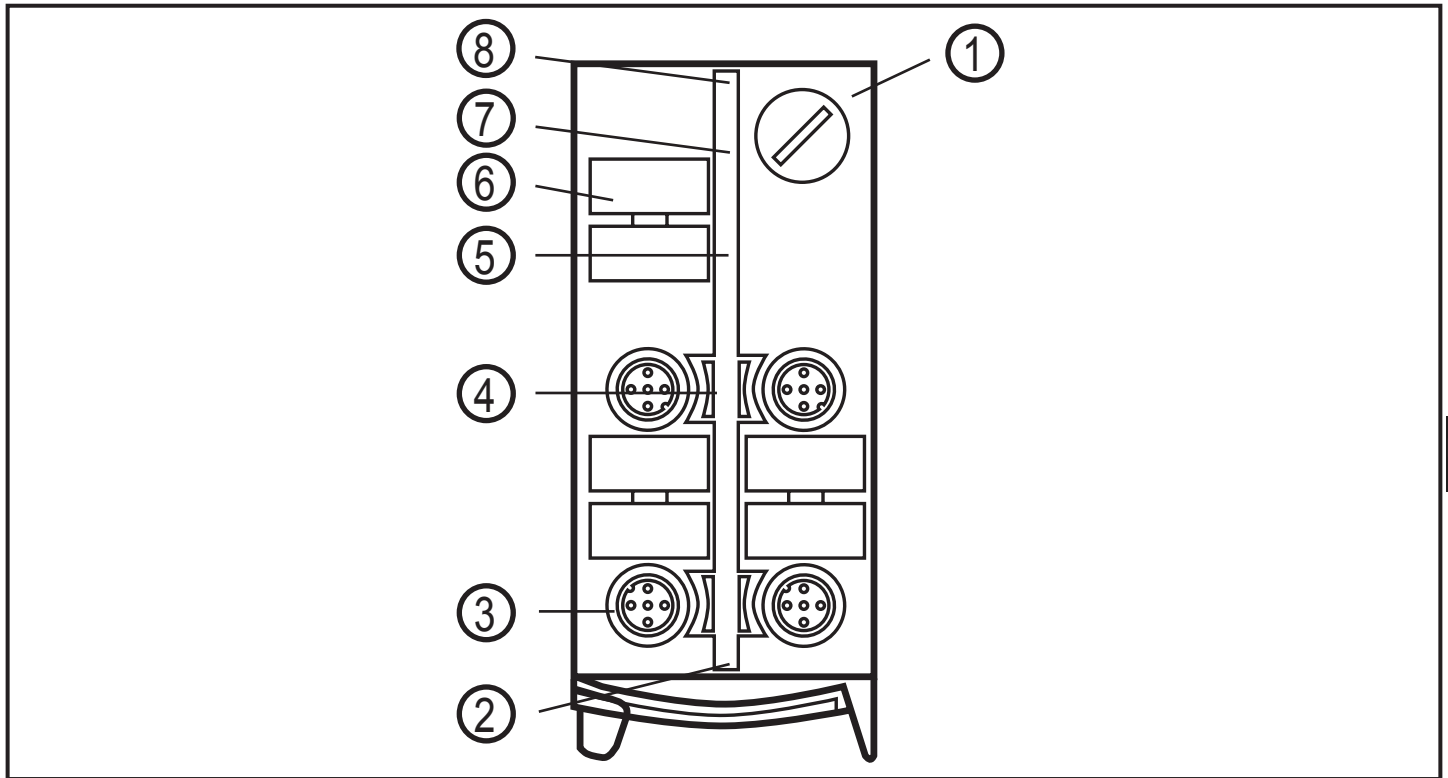

- 1: addressing interface
- 2: LED AUX
- 3: 4 M12 sockets
- 4: LED 2
- 5: LED 1
- 6: labels
- 7: LED FAULT
- 8: LED PWR

## 6 Addressing

The address is set to 0 at the factory.

### 6.1 Addressing with the AC1154 addressing unit

When mounted and wired the module can be addressed with the addressing cable (E70213) via the integrated addressing interface.

If a slave with the extended addressing mode is used in combination with a master of the first generation (version 2.0), the parameter P3 must be 1 and the output bit D3 must be 0\*. The output bit D3 and the parameter bit P3 must not be used.

\*default setting

If a slave with the extended addressing mode is used in combination with a master of the first generation (version 2.0), an address between 1A and 31A must be assigned to this slave.

## AC5234

2 outputs (2 Ampère) / 2 inputs

AS-i profile S-B.A.E / extended addressing mode: yes

Data bit	D0	D1	D2	D3
Input	-	-	I3	I4
Socket	-	-	I-3/4	I-3/4   I-4
Output	O1	O2	-	-
Socket	O-1/2	O-1/2   O-2	-	-

Y-circuit inputs

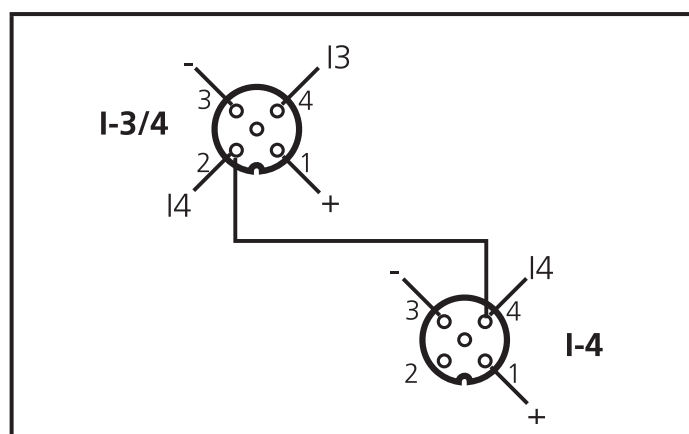

Y-circuit outputs

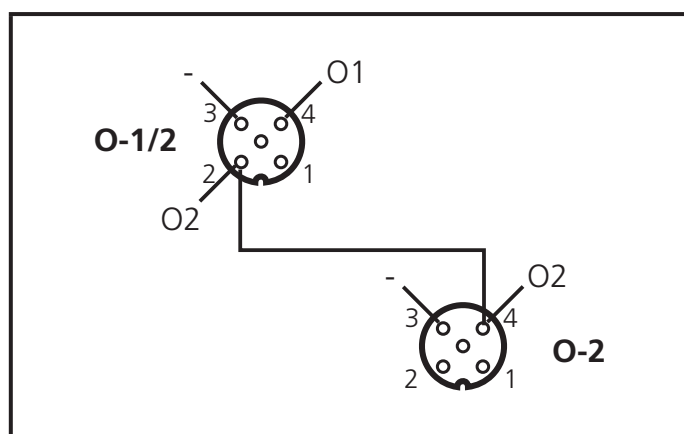

## 7 Electrical connection



The unit must be connected by a qualified electrician.

The national and international regulations for the installation of electrical equipment must be adhered to.

- ▶ Disconnect power.
- ▶ Connect the unit.

Connect the plugs of the sensors / actuators to the M12 sockets, tightening torque 0.6...0.8 Nm. Cover the unused sockets with protective caps (E73004)\*, the addressing socket with the supplied protective cap. Tightening torque 0.6...0.8 Nm.

To guarantee protection rating IP 67 you also have to

- use the flat cable end seal (E70413)\* if the module is at the end of the cable line

\* to be ordered separately

## 8 Operation



Avoid build-up of dirt and dust on the upper and lower parts so that the locking mechanism is not affected.

- LED 2 yellow: input / output switched
- LED PWR green: AS-i voltage supply ok
- LED AUX green: AUX voltage supply ok
- LED FAULT red lights: AS-i communication error, slave does not participate in the „normal“ exchange of data, e.g. slave address 0
- LED FAULT red flashes: peripheral fault, e.g. sensor supply / output overloaded or shorted
- LED 1 yellow: logic state of the outputs



Overload and short circuit of the input supply and the outputs are signalled as peripheral fault to the AS-i master (version 2.1 or higher).

## 9 Technical data

Technical data and further information at [www.ifm.com](http://www.ifm.com).