

ifm electronic

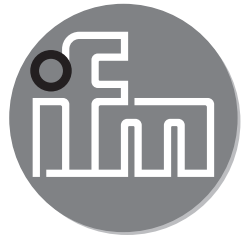

Operating instructions
Retro-reflective sensor

efector200[®]

O5P5xA

UK

704500 / 00 10 / 2008

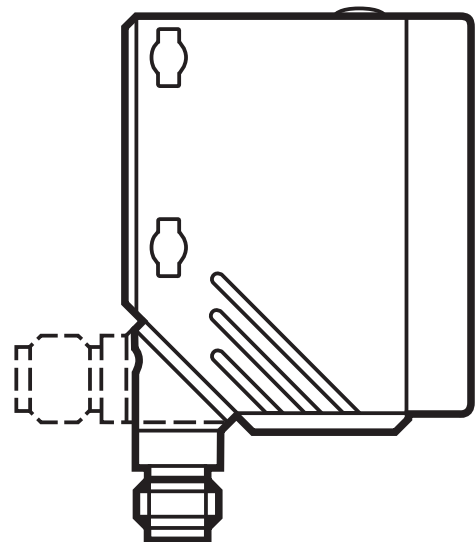

1 Preliminary note

1.1 Symbols used

▶ Instruction

> Reaction, result

[...] Designation of pushbuttons, buttons or indications

→ Cross-reference



Important note

Non-compliance can result in malfunctions or interference.

2 Safety instructions

- Please read this document prior to set-up of the unit. Ensure that the product is suitable for your application without any restrictions.
- Observe the instructions for the safe use in hazardous areas: → Operating instructions (Ex protection related part) for photoelectric sensors according to EU directive 94/9/EC annex VIII (ATEX) group II, equipment category 3D.

If no operating instructions (Ex protection related part) or EC declaration of conformity is supplied with this product in the language of the EU user country, these can be requested from your dealer (see delivery note) or manufacturer (see cover sheet / back).

3 Functions and features

In conjunction with a prismatic reflector or reflective tape the retro-reflective sensor detects objects and materials without contact and indicates their presence by a switching signal.

Range → type label.

4 Installation

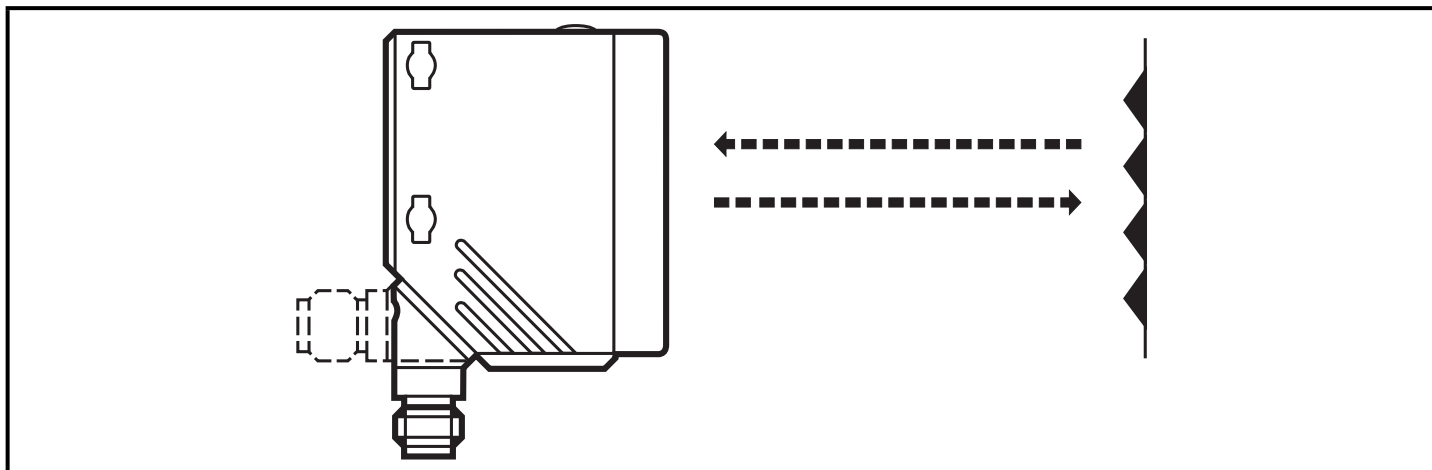

- ▶ Fit the prismatic reflector or the reflective tape behind the object to be detected.
- ▶ Align the retro-reflective sensor to it and secure it to a bracket.

Maximum range is only possible with precise alignment.

5 Operating and display elements

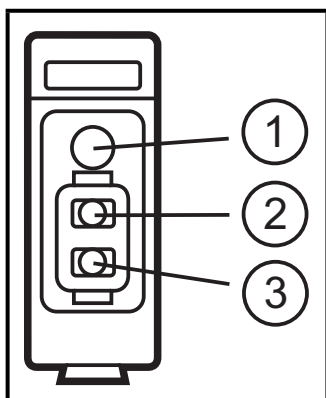

- 1: LED
- 2: [OUT on]
- 3: [OUT off]

6 Electrical connection



The unit must be connected by a qualified electrician.

- ▶ The national and international regulations for the installation of electrical equipment must be adhered to.
- ▶ Ensure voltage supply according to EN 50178, SELV, PELV.

- ▶ Disconnect power.
- ▶ Connect the unit as follows:

DC PNP

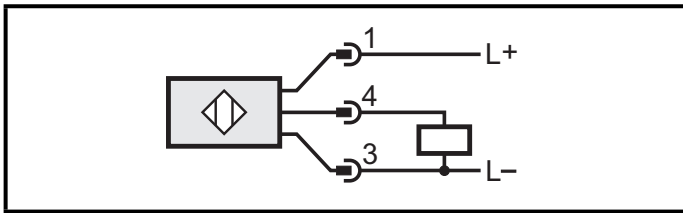

pin 1 = L+
 (pin 2 = not connected)
 pin 3 = L-
 pin 4 = load

7 Settings

7.1 The sensor is to switch when the object is detected

1	<p>▶ Position the object.</p>
	<p>▶ Press [OUT on] for 2 s.</p> <ul style="list-style-type: none"> > The sensitivity is set to the object. > The yellow LED flashes.
2	<p>▶ Remove the object.</p>
	<p>▶ Press [OUT off].</p> <ul style="list-style-type: none"> > The sensitivity is set without object. > The yellow LED goes out. The programming is finished.

7.2 The sensor is not to switch when the object is detected

- ▶ Position the object (see figure 1) and press [OUT off].
- ▶ Remove the object (see figure 2) and press [OUT on].

The setting can also be carried out first without object (step 1) and then with object (step 2).

7.3 Setting of the maximum sensitivity

- ▶ Align the sensor so that no light is reflected.

The sensor is to switch when the object is detected

- ▶ First press [OUT on], then [OUT off].

The sensor is to switch when the object is not detected

- ▶ First press [OUT off], then [OUT on].

7.4 Programming unsuccessful

- > The LED flashes quickly, 8 Hz.
 - Measured value difference too small.
 - Max. programming time of 15 min. exceeded.

7.5 Electronic lock

Lock or unlock the buttons

- ▶ Press [OUT on] and [OUT off] simultaneously for 10 s.
- > Acknowledgement is indicated by a change of the LED status.

8 Operation

- ▶ Check whether the unit operates correctly.
- > The LED lights when the switching output is switched.

9 Maintenance, repair and disposal

- ▶ Keep the front pane of the sensor free from soiling.
- ▶ For cleaning do not use any solvents or cleaning agents which could damage the plastic material.

Technical data and further information at
www.ifm.com → Select your country → Data sheet direct: