



Operating instructions
ClassicLine module

AC5216

AC5226

GB

11461353/00 05/2022



Contents

1 Preliminary note.....	3
1.1 Safety instructions	3
1.2 Symbols used	3
2 Functions and features	4
3 Operating and display elements	5
4 Installation.....	6
5 Addressing.....	11
5.1 Addressing with the AC1154 addressing unit.....	11
6 Electrical connection.....	11
6.1 Wiring analogue input.....	11
6.2 Current measurement AC5216	12
6.3 Current measurement AC5226.....	13
7 Parameter setting of the analogue module.....	14
8 Measuring range of the device	15
9 Operation.....	16

1 Preliminary note

Technical data, approvals, accessories and further information at www.ifm.com.

1.1 Safety instructions

- Read this document before setting up the product and keep it during the entire service life.
- The product must be suitable for the corresponding applications and environmental conditions without any restrictions.
- Only use the product for its intended purpose (→ Functions and features).
- If the operating instructions or the technical data are not adhered to, personal injury and/or damage to property may occur.
- The manufacturer assumes no liability or warranty for any consequences caused by tampering with the product or incorrect use by the operator.
- Installation, electrical connection, set-up, operation and maintenance of the product must be carried out by qualified personnel authorised by the machine operator.
- The plant manufacturer is responsible for the safety of the plant in which the device is installed.
- If the device is used in a way that is not intended by the manufacturer, the protection supported by the device may be impaired.
- Protect units and cables against damage.

1.2 Symbols used

▶ Instructions

→ Cross-reference



Important note

Non-compliance may result in malfunction or interference.



Information

Supplementary note

2 Functions and features

The slave converts analogue input signals and transfers them to the AS-i master via the AS-Interface. The AS-i module operates as a slave with bidirectional data transfer in the AS-i network.

The data transfer to the host is asynchronous according to the AS-i profile S-7.3.E and the AS-i specification 3.0, downward compatible.

- Maximum number of modules per master: 31
- Current measurement 4...20 mA
- Maximum voltage drop across load for nominal current:
< 10 V (< 500 Ω)
- Time for converting the measured values in the slave and transmission via the AS-Interface in a fully expanded network
 - for one channel: 60 ms
 - for two channels: 120 ms
 - for three channels: channel 1: 120 ms / channel 2 and channel 3: 240 ms
 - for four channels: 240 ms

The analogue inputs and AS-i as well as AS-i and AUX are electrically separated.

The sensor supply (+ 24 V, 0 V) on pins 1 and 3 can be used to supply the sensors.

Max. 2 A may be taken from the sensor supply per module.

3 Operating and display elements

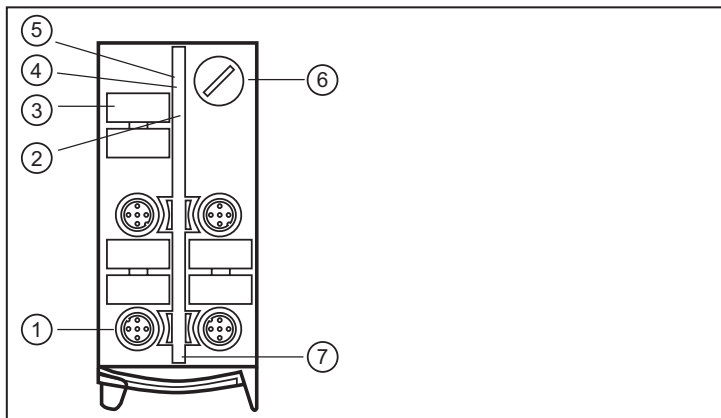

- 1: 4 M12 sockets
- 2: LEDs channels 1...4
- 3: Labels
- 4: LED FAULT
- 5: LED PWR
- 6: Addressing interface
- 7: LED AUX

4 Installation



▶ Disconnect the system from power before installation.

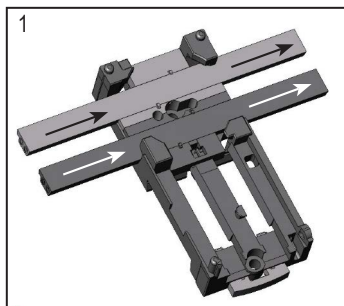

Alignment of the flat cable on delivery

Carefully place the yellow and optionally the black AS-i flat cable into the profile slot.

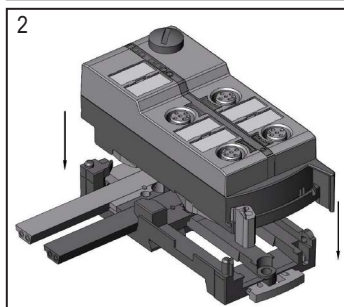

Mount the upper part.



Lock the unit.

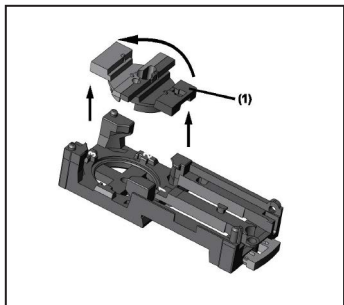

With the supplied lower part the flat cable can be aligned in three directions.

For the requested direction place the flat cable guide (1) accordingly.

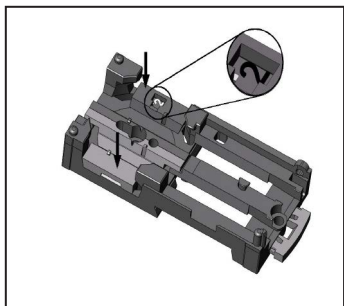

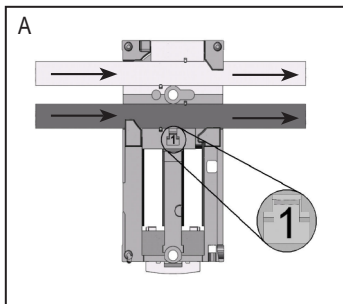

Settings at the lower part

Select the position 1, 2 or 3 depending on the required flat cable alignment (→).

A = factory setting

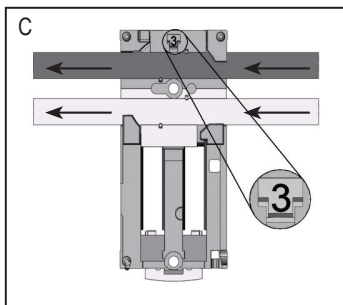
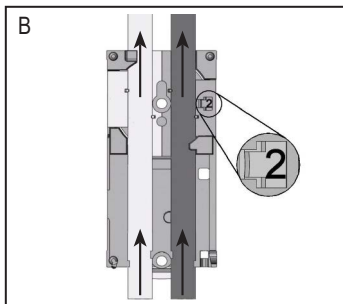

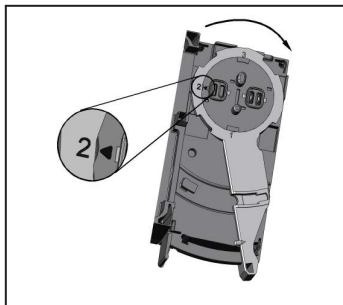

Settings at the upper part

Then set the selected position at the upper part. To do so, turn the triangle to the corresponding number (figures D1 and D2).

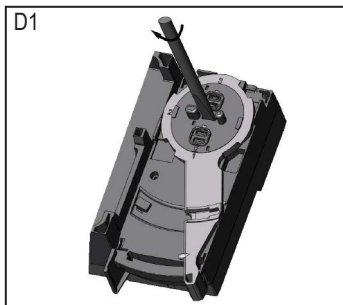

Use a tool, e.g. a screwdriver (figure D1) or the yellow / black flat cable guide (figure D2).

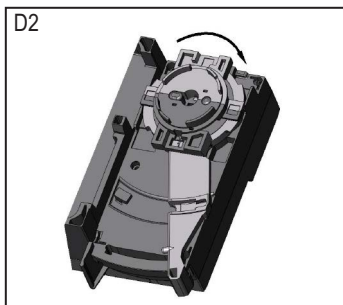

Open the unit



Open the unit using a tool as shown (e.g. screwdriver).

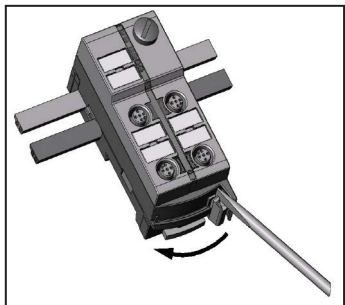

Take care in laying the AS-i flat cable, it should be laid straight for about 15 cm.

5 Addressing

- ▶ Assign a free address between 1 and 31.

The address is set to 0 at the factory.

5.1 Addressing with the AC1154 addressing unit

When mounted and wired the module can be addressed with the addressing cable (E70213) via the integrated addressing interface.

6 Electrical connection

Connect the plugs of the sensors to the M12 sockets.

To guarantee protection rating IP 67

- ▶ cover the unused sockets with protective caps (E73004)*, tightening torque 0.6...0.8 Nm.
- ▶ the flat cable end seal (E70413)* must be attached if the module is at the end of the cable line.

* to be ordered separately.



The signal cable length for external devices (sensors, actuators) is to be limited to max. 10 m.

The signal cables must not leave the building.

6.1 Wiring analogue input

AC5216		AC5226	
M12 socket	Pin	M12 socket	Pin
Sensor supply +24 V	1	Sensor supply +24 V	1
Analogue input AI +	2	Analogue input AI +	2
Sensor supply 0 V / AI -	3	Sensor supply 0 V	3
not connected (n.c.)	4	Analogue input AI -	4
Functional earth FE	5	Functional earth FE	5

6.2 Current measurement AC5216

In all the following wiring diagrams the indicated pin connection refers to the unit.

Wiring of a 2-wire sensor without own supply

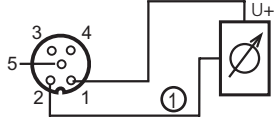
<ul style="list-style-type: none">• Pin 1: Sensor supply +24 V• Pin 2: Analogue input AI+• Pin 3: Sensor supply 0 V / analogue input AI-• Pin 4: not connected (n.c.)• Pin 5: Functional earth FE	
	1: analogue in current

Wiring of a 2-wire sensor with electrically isolated and earth-free supply

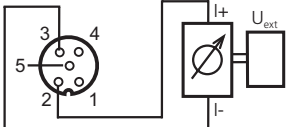
<ul style="list-style-type: none">• Pin 1: Sensor supply +24 V• Pin 2: Analogue input AI+• Pin 3: Sensor supply 0 V / analogue input AI-• Pin 4: not connected (n.c.)• Pin 5: Functional earth FE	
-----------------------------------------------------------------------------------------------------------------------------------------------------------------------------------------------------------------------------------------------------	-----------------------------------------------------------------------------------

Wiring of a 3-wire sensor without own supply

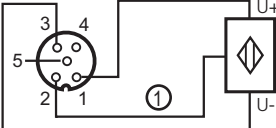
<ul style="list-style-type: none">• Pin 1: Sensor supply +24 V• Pin 2: Analogue input AI+• Pin 3: Sensor supply 0 V / analogue input AI-• Pin 4: not connected (n.c.)• Pin 5: Functional earth FE	
	1: analogue in current

6.3 Current measurement AC5226

In all the following wiring diagrams the indicated pin connection refers to the unit.

Wiring of a 2-wire sensor with own (grounded) supply

- 1: Sensor supply 24 V
- 2: Analogue input AI +
- 3: Sensor supply 0 V
- 4: Analogue input AI -
- 5: Functional earth FE

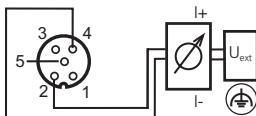

Wiring of a 2-wire sensor without own supply

- 1: Sensor supply 24 V
- 2: Analogue input AI +
- 3: Sensor supply 0 V
- 4: Analogue input AI -
- 5: Functional earth FE

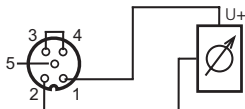

Wiring of a 3-wire sensor without own supply

- 1: Sensor supply 24 V
- 2: Analogue input AI +
- 3: Sensor supply 0 V
- 4: Analogue input AI -
- 5: Functional earth FE

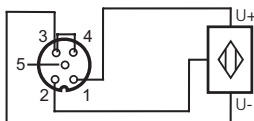

When connecting a 2-wire or 3-wire sensor without own supply there has to be an external link between pin 3 and pin 4.

Wiring of a 4-wire sensor without own supply

- 1: Sensor supply 24 V
- 2: Analogue input AI +
- 3: Sensor supply 0 V
- 4: Analogue input AI -
- 5: Functional earth FE

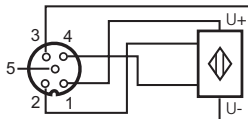

7 Parameter setting of the analogue module

Parameter bit	Description		Comments			
P0	1*	50 Hz	50/60 Hz suppression			
	0	60 Hz				
P1, P2	Channel activation **					
	P1	P2	Chan- nel 1	Chan- nel 2	Chan- nel 3	Chan- nel 4
	0	0	on	off	off	off
	0	1	on	on	on	off
	1	0	on	on	off	off
1*	1*	on	on	on	on	
P3	1*	peripheral fault indication active	peripheral fault if outside the measuring range			
	0	peripheral fault indication non active				
* default setting						
** The number of activated channels influences the conversion time and transmission time (see chapter 2).						

8 Measuring range of the device

► For the measuring ranges and their significance please refer to the following table:

Analogue input module 4...20 mA

Range [mA]	Unit dec.	Unit hex.	LED	Peripheral fault	Description
< 3.4	32768 → 32767 *	8000 → 7FFF *	flashing	on***	wire break
3.4...3.59	3400...3599 → 32767 *	0D48...0E0F → 7FFF *	flashing	off	below nominal range
3.6...22	3600...22000	0E10...55F0	on	off	extended and nominal range**
22.01...23	22001...23000 → 32767 *	55F1...59D8 → 7FFF *	flashing	off	above nominal range
> 23	32767	7FFF	flashing	on***	outside range

Note:

* the master replaces the value transmitted by the slave by the default value 7FFFh (32767)

** The accuracy is only guaranteed in the nominal range (4...20 mA) but not in the extended nominal range.

*** only for the parameter bit 3 = 1

9 Operation



Avoid build-up of dirt and dust on the upper and lower parts so that the locking mechanism is not affected.

Check whether the unit operates correctly. Display by LEDs:

Channel LED yellow on:	analogue signal in the nominal range (normal operation)
Channel LED yellow flashing:	analogue signal outside the measuring range or no sensor connected
Channel LED yellow off:	channel deactivated, parameter bit P1 or P2 = 0
LED green PWR on:	AS-i voltage is applied
LED red FAULT on:	AS-i communication error
LED red FAULT flashes:	Peripheral fault*
LED green AUX on:	External 24 V voltage is applied

* A peripheral fault is displayed, if

- at least one analogue signal of an activated channel (P1, P2) is outside the value range and parameter bit P3 is activated.
- nothing is connected to an activated channel and parameter bit P3 is activated.

