

Operating instructions
Photoelectric distance sensor

UK

OGD580

OGD581

11477285 / 00 04 / 2019

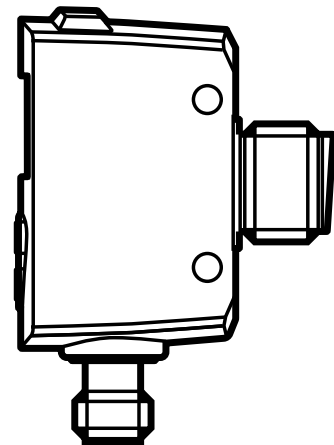

Contents

1	Preliminary note.....	4
1.1	Symbols used	4
1.2	Warnings used.....	4
2	Safety instructions	4
3	Functions and features	5
3.1	General notes	5
3.2	Application areas	6
3.3	Installation notes.....	6
3.3.1	Avoidance of soiling and ambient light	6
3.3.2	Avoidance of mutual interference	6
3.3.3	Sensor alignment to moving objects.....	7
4	Functions	7
4.1	Output function hysteresis	7
4.2	Output function window	7
4.3	Switch off the laser	7
5	Installation.....	8
5.1	Installation conditions	8
5.2	Mounting accessories	8
6	Electrical connection.....	8
6.1	Operation with IO-Link master	9
7	Operating and display elements	9
7.1	Meaning of the display colours	10
7.1.1	Use of the display colours in the menu.....	10
8	Menu	12
8.1	Menu structure for window function	12
8.2	Menu structure for hysteresis function.....	13
8.3	Explanation of the menu	14
9	Operating modes	16
9.1	Run mode	16
9.2	Display mode	16
9.3	Programming mode	16
10	Parameter setting	17

10.1	General parameter setting.....	17
10.1.1	Setting a parameter value	17
10.1.2	Change from menu level 1 to menu level 2.....	18
10.1.3	Electronic lock	18
10.2	Configuration of the basic settings	19
10.2.1	Selection of the display unit.....	19
10.2.2	Setting the display	19
10.2.3	Configure OUT1 / OUT2	19
10.2.4	Hysteresis function	20
10.2.5	Setting of the switch point for hysteresis function OUT1 / OUT2	21
10.2.6	Background teach for hysteresis function OUT1 / OUT2	21
10.2.7	Dynamic hysteresis	21
10.2.8	Window function	22
10.2.9	Setting of the switch points for window function OUT1 / OUT 2.....	23
10.2.10	Teach - Setting of the switch point for window function OUT1 / OUT2.....	23
10.3	Extended functions	24
10.3.1	Setting of the delay time for switching outputs	24
10.3.2	Setting of the fault suppression time for switching outputs.....	24
10.3.3	Reset of all parameters to factory setting	24
11	IO-Link	24
11.1	General information	24
11.2	Device-specific information	25
11.3	Parameter setting tools	25
11.4	Functions	25
12	Set-up / operation	25
12.1	Error indications.....	25
13	Maintenance, repair and disposal.....	26
14	Scale drawing	26
15	Factory setting	27

1 Preliminary note

1.1 Symbols used

- ▶ Instructions
- > Reaction, result
- [...] Designation of keys, buttons or indications
- Cross-reference



Important note

Non-compliance may result in malfunction.



Information

Supplementary note.

1.2 Warnings used

WARNING

Warning of serious personal injury.

Death or serious irreversible injuries may result.

2 Safety instructions

- Please read this document prior to set-up of the unit. Ensure that the product is suitable for your application without any restrictions.
- Improper or non-intended use may lead to malfunctions of the unit or to unwanted effects in your application. That is why installation, electrical connection, set-up, operation and maintenance of the unit must be carried out by qualified personnel authorised by the plant operator.
- In case of malfunction of the unit please contact the manufacturer. If the unit is tampered with and/or modified, any liability and warranty is excluded.



Caution - Use of controls or adjustments or procedures other than those specified herein may result in hazardous radiation exposure.



Visible laser light; LASER CLASS 1.

EN/IEC 60825-1 : 2007 and EN/IEC 60825-1 : 2014
complies with 21 CFR 1040 except for deviations
pursuant to Laser Notice No. 50, dated June 2007.

Position of the product label

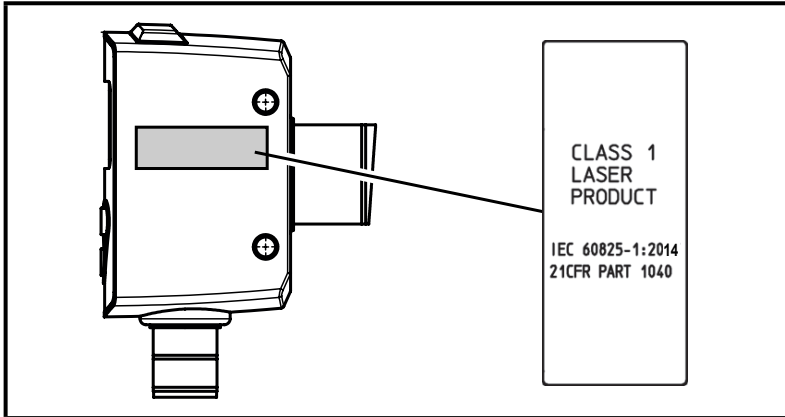

Label

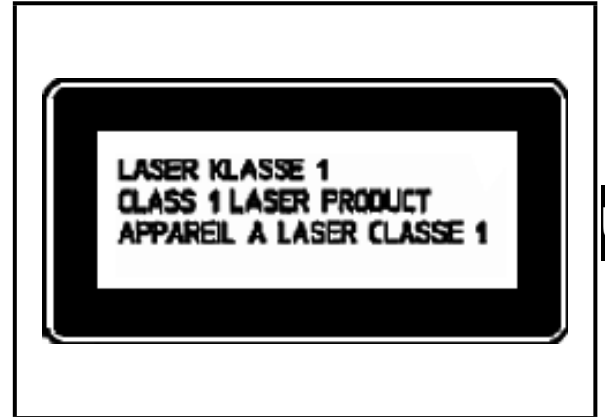

3 Functions and features

3.1 General notes

The unit is used as an optical distance sensor.

The unit continuously detects the distance to the object and generates output signals according to the parameter settings.

- 2 switching outputs are available. They can be set separately. Switch points can either be set or taught.
- The measured value is shown in a 7-segment display and transferred via IO-Link. Two measured values are generated.

Measured distance value:

The distance from the sensor to the target provides the primary measured value.

Object reflectivity:

The reflexivity of the target is also determined.

- This measured value is suitable for monitoring and detecting sensor soiling.

The unit uses a laser diode as light source and creates a light spot. This makes it possible to detect small objects.



The light spot should hit the object or the background. Intermediate states may lead to faulty measured values.

3.2 Application areas

- The optical distance sensor measures distances between 2,5...150 cm.
- It has a background suppression of up to 20 m.



The distance between the sensor and the background must be limited to max. 20 m. Otherwise measured values can be ambiguous. → 5.1

3.3 Installation notes

3.3.1 Avoidance of soiling and ambient light

Preferably align photoelectric sensors with the front lens facing downwards or parallel to the earth's surface.

Background:

- Photoelectric sensors are sensitive to ambient light. Everyday light sources (lamps, sun) radiate from above.
- Photoelectric sensors react sensitively to soiling, as it reduces the excess gain.



Dust deposits can be reduced by downwards or sideways orientation. This allows for longer cleaning intervals.



Make sure that sensors installed with their front lens facing upwards are not oriented towards roof windows or ceiling lamps.

3.3.2 Avoidance of mutual interference

Photoelectric sensors should be installed with a sufficient distance between each other. This particularly applies if the detection range of the two sensors partly intersects.

Background:

- Both sensors have a detection range. This means that the laser light spot of a sensor can be received by its neighbouring sensor. This may lead to the falsification of the measured values and result in incorrect switching.



Mutual interference can be avoided by placing the sensors slightly tilted. Align the light spots so that they impinge as far away from each other as possible.

3.3.3 Sensor alignment to moving objects

Photoelectric sensors have to be installed in a way to ensure that the object is moved into the detection range of the sensor from the side or from the bottom.

Background:

- When the object approaches from the top, it initially covers part of the receiver lens without being detected by the light spot. So far, the sensor only "sees" the background.
- If the object completely covers the receiving lens without the light spot detecting the object, the sensor cannot "see" the background any more. The sensor provides the error indication [--], as no signal is detected any more. When the object approaches further, it is eventually detected.



Avoidance of the error indication by increasing the parameter [dFO] (→ 10.3.2 Setting of the fault suppression time for switching outputs).

4 Functions

4.1 Output function hysteresis

The hysteresis keeps the switching state of the output stable if the measured value varies about the sensing range. Both outputs (OUT1 and OUT2) can be set as hysteresis function (→ 10.2.4 Hysteresis function).

4.2 Output function window

The window function enables the monitoring of a defined acceptable range. Both outputs (OUT1 and OUT2) can be set as window function → 10.2.8.

4.3 Switch off the laser

The laser can be switched off via the input on pin 5.

Input signal at pin 5		Laser
PNP	NPN	
Low / not used	High / not used	On
High	Low	Off

5 Installation

5.1 Installation conditions

- ▶ Install the unit so that the object to be detected is within the specified measuring range.

The unambiguity range of the sensor is fixed to 20 m. Objects outside the measuring range will be suppressed up to the limit of the unambiguity range (20 m).



Reflecting objects in the direct beam path of the sensor – also in the range < 20 m – are to be avoided by the customer. Otherwise the measured values can be ambiguous.

5.2 Mounting accessories

The unit is supplied with mounting accessories.

Pieces	Mounting accessories	Art. no.
2x	Metal lock nuts	E10027

6 Electrical connection



The unit must be connected by a qualified electrician.

- ▶ The national and international regulations for the installation of electrical equipment must be adhered to.
 - ▶ Ensure voltage supply to EN 50178, SELV, PELV. OGD580 and OGD581: cULus, Supply Class 2
- ▶ Disconnect power.
- ▶ Connect the unit as follows:

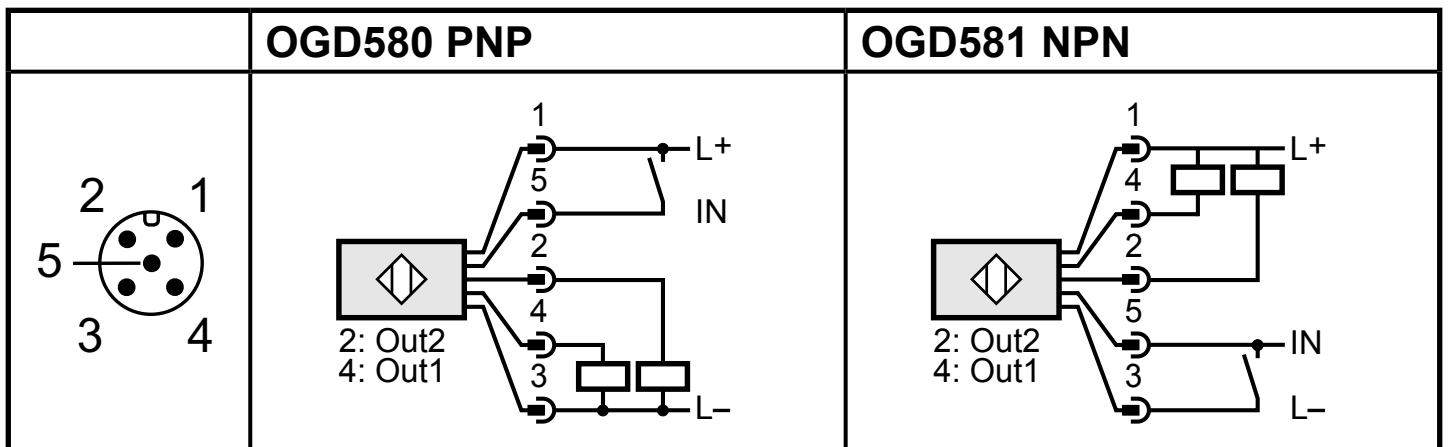

Core colours of ifm sockets:

1 = BN (brown), 2 = WH (white), 3 = BU (blue), 4 = BK (black), 5 = GR (grey).

6.1 Operation with IO-Link master

The unit is compatible with IO-Link master port class A (type A).



For operation with IO-Link master port class B (type B) observe the following:

As a standard, the unit is not compatible with master port class B (type B). Pin 2 (OU2) and pin 5 (IN1) are used for manufacturer-specific functions. That means that the main supply voltage of the unit and the additional voltage supply (master port class B on pins 2/5) are not electrically isolated.

With the following configurations the unit can be used with master port class B:

- Connect unit and IO-Link master via 3 wires: Connect pins 1, 3 and 4 of the unit with the IO-Link master (do not connect pins 2 and 5).
- Connect unit and IO-Link master via 4 wires: Deactivate pin 2 (OU2) via IO-Link (setting OU2 = "off") and connect pins 1, 2, 3 and 4 of the unit with the IO-Link master (do not connect pin 5).

UK

7 Operating and display elements

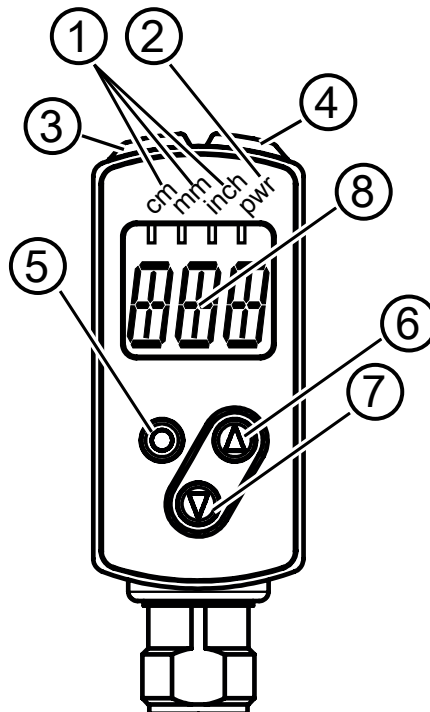

1:	3 x LED green	Active LED = set display unit (cm, mm, inch)
2:	1 x LED green	Active LED = power
3:	1x LED orange	Switching status Out 1
4:	1x LED orange	Switching status Out 2

5:	Programming button [ENTER]	Selection of the parameters and acknowledgement of the parameter values.
6:	Programming button "up"	Setting of the parameter values (scrolling by holding pressed; incremental by pressing briefly).
7:	Programming button "down"	Setting of the parameter values (scrolling by holding pressed; incremental by pressing briefly).
8:	3-digit alphanumeric display	Indication of the measured distance, the parameters and parameter values.

7.1 Meaning of the display colours

7.1.1 Use of the display colours in the menu

Menu level	Green	Red
0	X	X
1		X
2		X

The colours indicate the logic state of the sensor.



The green display colour indicates that there is an object in the monitored area, regardless of the setting of the switching outputs.

Example fig. 1 (setting Out 1 / Out 2 = hno)

Display is green if:

- measured value \leq SP1
- measured value \leq SP2

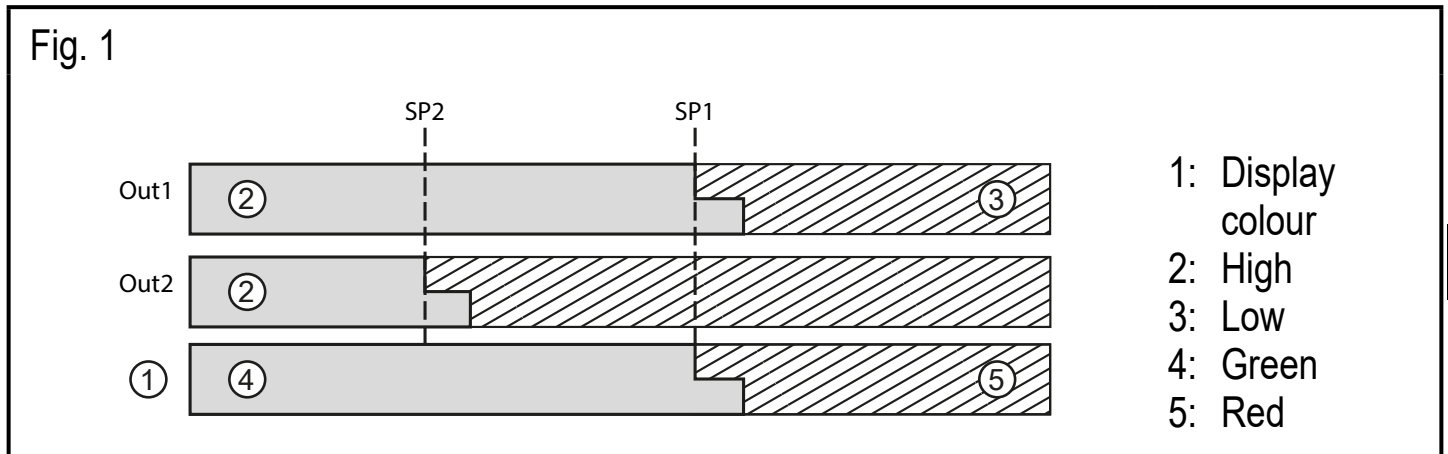

Example fig. 2 (setting Out 1 / Out 2 = fno)

Display is green if:

- $nP1 \leq$ measured value \leq FP1
- $nP2 \leq$ measured \leq FP2

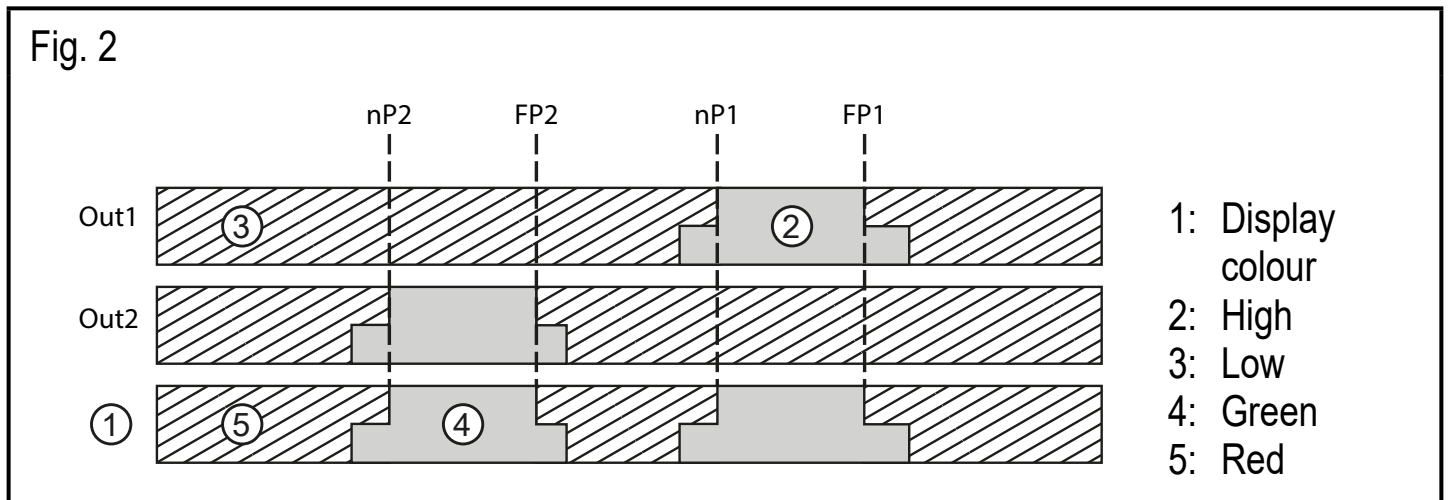

UK

8 Menu

8.1 Menu structure for window function

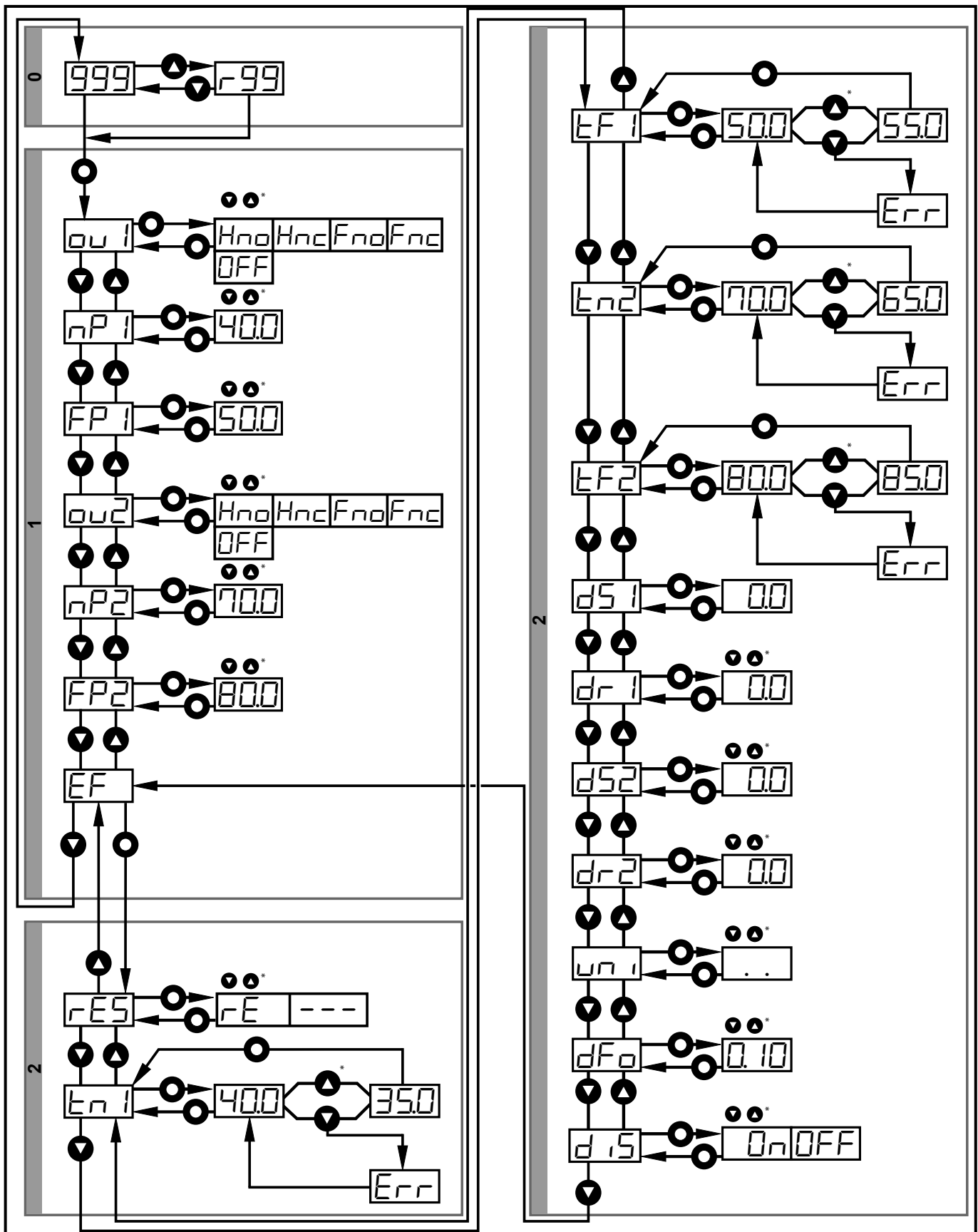

*) Keep the arrow key (up or down) pressed for 3 s for activation. Then press the key several times or keep it pressed for fast scrolling.

○ = [ENTER]

▲ = "Up" button

▼ = "Down" button

8.2 Menu structure for hysteresis function

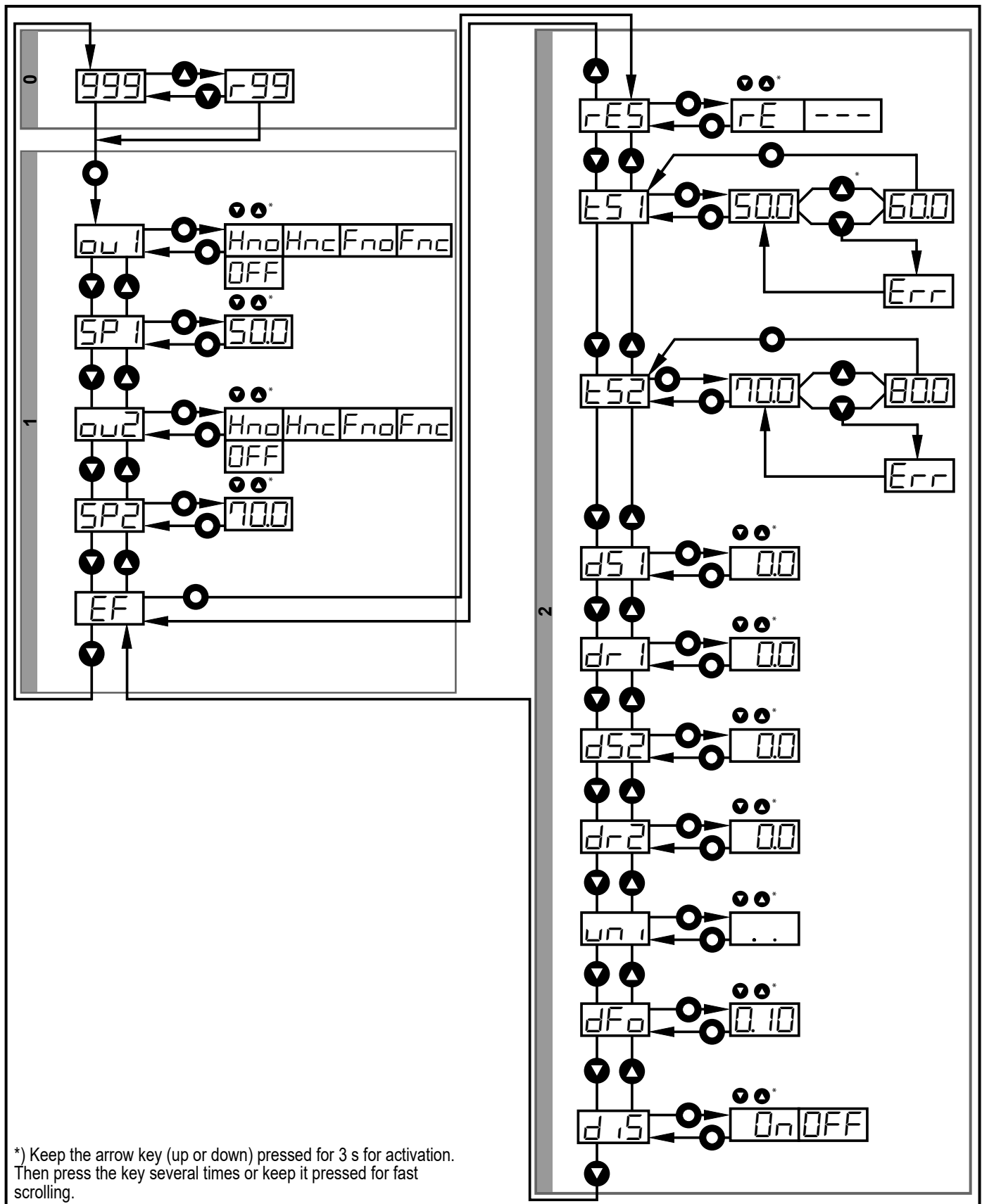

*) Keep the arrow key (up or down) pressed for 3 s for activation. Then press the key several times or keep it pressed for fast scrolling.

○ = [ENTER]

▲ = "Up" button

▼ = "Down" button

UK

8.3 Explanation of the menu

For the factory settings please refer to the end of these instructions (→ 15 Factory setting).

OU 1	Configuration for output 1 5 switching functions can be selected: [Hno], [Hnc], [Fno], [Fnc], [OFF] → 10.2.3 Configure OUT1 / OUT2.
OU 2	Configuration for output 2 5 switching functions can be selected: [Hno], [Hnc], [Fno], [Fnc], [OFF] → 10.2.3 Configure OUT1 / OUT2.
SP 1 SP 2	Switch point for hysteresis function OUT1 / 2 Value at which the output with selected hysteresis function changes its switching state (object nearer/farther than distance set). [SP1/2] is only active if [OU1/2] = [Hno] or [Hnc] → 10.2.5 Setting of the switch point for hysteresis function OUT1 / OUT2.
nP 1 FP 1 nP 2 FP 2	Switch points for window function OUT1 Values at which the output with selected window function changes its switching state (object present / not present between the distance "near" and the distance "far"). [nP1/2] = switch point "near" / [FP1/2] = switch point "far". [nP1/2] / [FP1/2] are only active if [OU1/2] = [Fno] or [Fnc] → 10.2.9 Setting of the switch points for window function OUT1 / OUT 2.
EF	Extended functions Press [ENTER] to open the submenu "Extended functions" → 10.3 Extended functions.
rES	Restore the factory setting → 10.3.3 Reset of all parameters to factory setting.
dS 1 dr 1 dS 2 dr 2	Delay for the switching outputs [dSx] = switch-on delay; [drx] = switch-off delay. The output does not immediately change its switching state when the switching condition is met but only after the delay has elapsed. If the switching condition is no longer met after the delay has elapsed, the switching state of the output does not change. [dSx] and [drx] are not effective if [OU1/2] = [OFF] → 10.3.1 Setting of the delay time for switching outputs.

<p>LS1 LS2</p>	<p>Background teach for hysteresis function OUT1 / 2 Limit value at which the output with selected hysteresis function changes its switching state (object nearer/farther than distance set). [tS1] is only active if [OU1] = [Hno] or [Hnc] [tS2] is only active if [OU2] = [Hno] or [Hnc] (→ 10.2.6 Background teach for hysteresis function OUT1 / OUT2).</p>
<p>Ln1 LF1 Ln2 LF2</p>	<p>Teach - Switch points for window function OUT1 / 2 Limit values at which the output with selected window function changes its switching state (object present / not present between the distance "near" and the distance "far"). [tn1] = switch point "near" / [tF1] = switch point "far". [tn1] / [tF1] are only active if [OU1] = [Fno] or [Fnc]. [tn2] = switch point "near" / [tF2] = switch point "far". [tn2] / [tF2] are only active if [OU2] = [Fno] or [Fnc]. (→ 10.2.10 Teach - Setting of the switch point for window function OUT1 / OUT2)</p>
<p>dFo</p>	<p>Setting of the fault suppression time for switching outputs This function suppresses brief saturation of the measuring element (such saturation may result from direct reflection or strong fluctuations in brightness). During the set delay time, the latest valid value measured is displayed, the output signals remain unchanged. (→ 10.3.2 Setting of the fault suppression time for switching outputs)</p>
<p>d15</p>	<p>Setting of the display 2 settings can be selected: [on], [OFF] With the setting [OFF] the display is switched off automatically after 30 sec. Only the "power-on" LED remains active. Each push of the button re-activates the display for 15 sec. (→ 10.2.2 Setting the display)</p>
<p>Un1</p>	<p>Setting of the display unit Selection of the unit of measurement for [SP1], [SP2], [nP1], [nP2], [FP1], [FP2] Options: [cm], [Inch] (→ 10.2.1 Selection of the display unit)</p>

9 Operating modes

9.1 Run mode

The run mode is the normal operating mode.

After power on the unit is in the run mode. It carries out its monitoring function and generates output signals according to the set parameters.

The display indicates the current distance or the object reflectivity, the yellow LEDs signal the switching state of the outputs.



The measuring distance is displayed in the set unit.

Object reflectivity:

- Value range 1...99

Example:

- r99 corresponds to a white object
- r20 corresponds to a grey object

Switch between the two measured values via the "up" or "down" button.

9.2 Display mode

Indication of the parameters and the set parameter values.

- ▶ Press [ENTER] briefly.
- > The unit goes to the display mode. Internally it remains in the operating mode. The set parameter values can be read:
 - ▶ To scroll through the parameters, press the "up"/"down" button briefly.
 - ▶ To display the parameter value, press [Enter] briefly.
- > After another 15 s the unit returns to the run mode.

9.3 Programming mode

Setting the parameter values → 10.1 General parameter setting.

10 Parameter setting

During parameter setting the unit remains internally in the operating mode. It continues its monitoring function with the existing parameters until the change has been completed.

10.1 General parameter setting

10.1.1 Setting a parameter value



Set the display unit [Uni] before the values for the parameters are defined. In case of subsequent changes of the display unit rounding errors during internal conversion to other units may falsify the set values. → 10.2.1 Selection of the display unit.

UK

<p>1</p>	<p>Select parameter</p> <ul style="list-style-type: none"> ▶ Press [ENTER] to access menu level 1. ▶ Press the "up"/"down" button until the requested parameter is displayed. 	
<p>2</p>	<p>Set parameter value</p> <ul style="list-style-type: none"> ▶ Press [Enter] briefly. > The current parameter value is displayed. ▶ Press the "up" or "down" button and keep it pressed. > The current parameter value flashes for 3 s. ▶ Increase the setting value step by step by pressing the button once or continuously by holding it down. 	
<p>Decrease the value: let the display move to the maximum setting value. Then the cycle starts again at the minimum setting value.</p>		
<p>3</p>	<p>Confirmation of the parameter value</p> <ul style="list-style-type: none"> ▶ Briefly press [ENTER]. > Back to menu level 1 > The parameter is displayed again; the new parameter value is effective. 	

4	<p>Setting of other parameters</p> <ul style="list-style-type: none"> ▶ Select a parameter as described in step 1 and continue with step 2.
5	<p>Finish parameter setting</p> <ul style="list-style-type: none"> ▶ Wait for 15 s or press the "up" and "down" button. ▶ If necessary, repeat several times to access menu level 0. > The current measured value is displayed.

10.1.2 Change from menu level 1 to menu level 2

<ul style="list-style-type: none"> ▶ Press the "down" button until [EF] is displayed. 	
<ul style="list-style-type: none"> ▶ Briefly press [Enter]. > The first parameter of the submenu is displayed (here: [rES]). 	

10.1.3 Electronic lock

The unit can be locked electronically to prevent unauthorised setting. On delivery the unit is not locked.

<p>Locking</p> <ul style="list-style-type: none"> ▶ Make sure that the unit is in the normal operating mode. ▶ Keep the "up" + "down" button pressed (approx. 10 s) until [Lo] is displayed. > The unit is locked. 	
<p>[Lo] is displayed briefly if you try to change parameter values on the locked unit during operation.</p>	

Unlocking

- ▶ Keep the "up" + "down" button pressed until [uLo] is displayed.
- > The unit is unlocked.

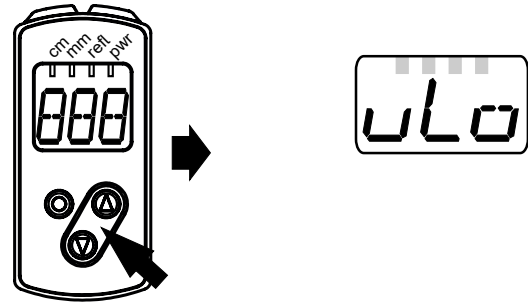

Timeout



If no button is pressed for 15 s during the setting procedure, the unit returns to the run mode with unchanged values.

UK

10.2 Configuration of the basic settings

10.2.1 Selection of the display unit

Set [Uni] before the values for the parameters [SPx], [nPx], [FPx] are defined.

In case of subsequent changes of the display unit rounding errors during internal conversion to other units may falsify the set values.

- ▶ Change to [EF].
- ▶ Select [Uni] and set the unit of measurement.
Selection of the unit of measurement: [cm], [Inch]
- ▶ Confirm with [ENTER].
- > The selected unit is indicated by a green LED on the display.

Uni

10.2.2 Setting the display

- ▶ Change to [EF].
- ▶ Select [diS] and make settings.
2 settings can be selected:
 - [On] = the measured value display is activated in the run mode.
 - [OFF] = the measured value display is deactivated in the run mode.When one of the buttons is pressed, the current measured value is displayed for 15 s.
- ▶ Confirm with [ENTER].

The LEDs remain active even if the display is deactivated.

d 15

10.2.3 Configure OUT1 / OUT2

- ▶ Select [OU1] / [OU2] and set the switching functions.
Switching functions:
 - [Hno] = hysteresis function / normally open
 - [Hnc] = hysteresis function / normally closed
 - [Fno] = window function / normally open
 - [Fnc] = window function / normally closed
 - [OFF] = switching output is deactivated
- ▶ Confirm with [ENTER].

OU1
OU2

10.2.4 Hysteresis function

The hysteresis keeps the switching state of the output stable if the measured value varies about the sensing range. The selected switch point [SPx] is the set point. The reset point is automatically set above the selected switch point [SPx] by the sensor. The nominal distance between switch-on pint and reset point is the hysteresis, it is indicated in the data sheet. The hysteresis depends on the reflectivity of the background.

Example Hno

1. For the output function [Hno] the output switches when the object approaches and when the set point (A) is reached.
2. When the object is removed again, the output does not switch back before the reset point (B) is exceeded.

The reset point (B) is above the set point (A).

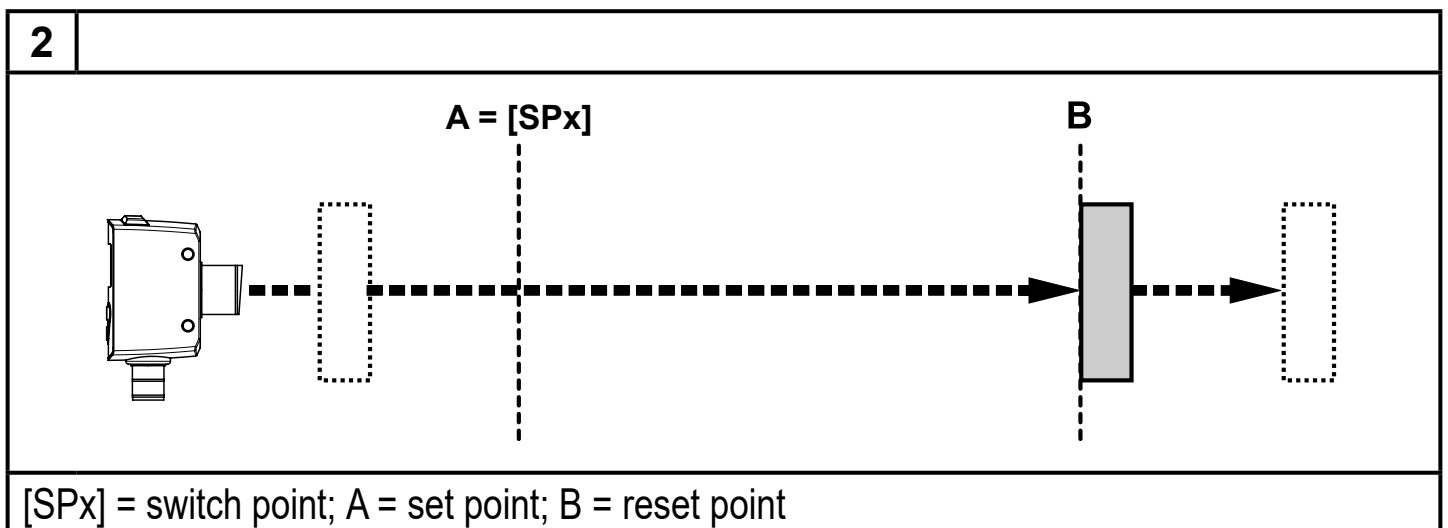
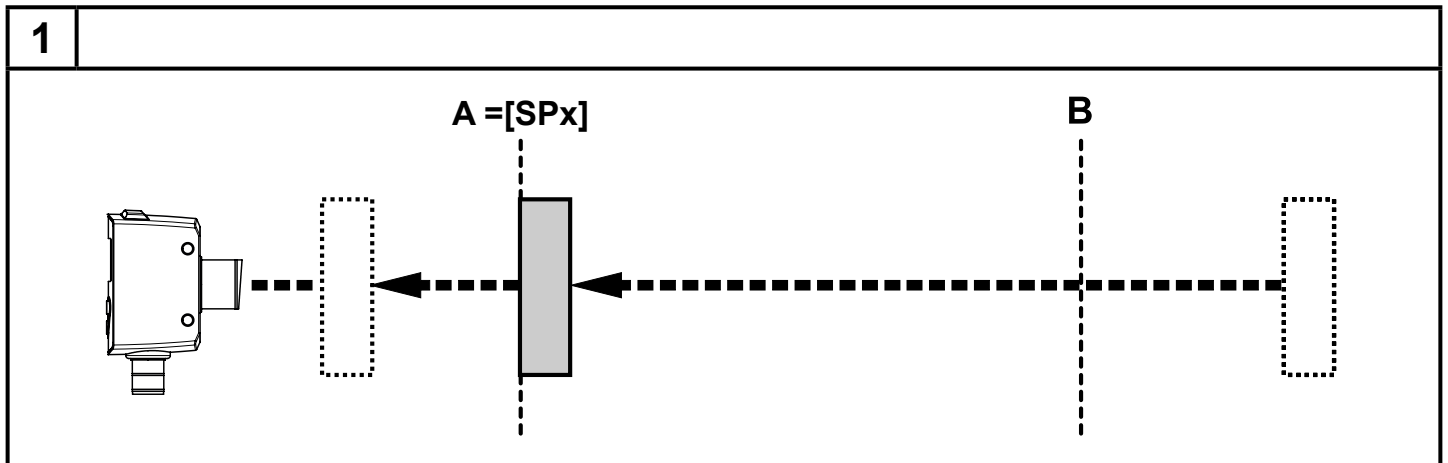

If the output function [Hnc] has been selected, the set and reset points are reversed. The output switches off when the object approaches. When the object is removed again, the output switches.

Switching status of the outputs

Output function	Object distance (D)	Switching status
[Hno]	D < [SPx]	Closed
	D > [SPx]	Open
[Hnc]	D < [SPx]	Open
	D > [SPx]	Closed

10.2.5 Setting of the switch point for hysteresis function OUT1 / OUT2

<ul style="list-style-type: none"> ▶ Change to [EF]. ▶ In [OU1] select the output function [Hno] or [Hnc]. ▶ Confirm with [ENTER]. ▶ Select [SP1] and set the switch point. ▶ Confirm with [ENTER]. 	
--	---

UK

10.2.6 Background teach for hysteresis function OUT1 / OUT2

<ul style="list-style-type: none"> ▶ Change to [EF]. ▶ In [OU1] select the output function [Hno] or [Hnc]. ▶ Confirm with [ENTER]. ▶ Select [tS1]. > Parameter value for [SP1] is displayed. ▶ Press the "up" or "down" button and keep it pressed. > The parameter value flashes for 3 s. > New parameter value is displayed. ▶ Confirm with [ENTER]. > The taught value is saved in [SP1]. 	
--	--

10.2.7 Dynamic hysteresis

The measured values detected by the sensor vary depending on the situation. The highest fluctuation of measured values occurs in case of a small signal to noise ratio. This is the case when very dark targets are detected and when there is very much ambient light. Therefore, the reset point is automatically set by the sensor after [SPx] has been selected.

Very dark background = high hysteresis is selected.

Very bright background = small hysteresis is selected.

The minimum distance between object and background can be reduced if the background is very bright (e.g. white).

A bright background enables the detection of smaller objects.

10.2.8 Window function

It is possible to define a window for the object recognition for each of the two outputs (OUT1 / OUT2).

Switches when the object is detected

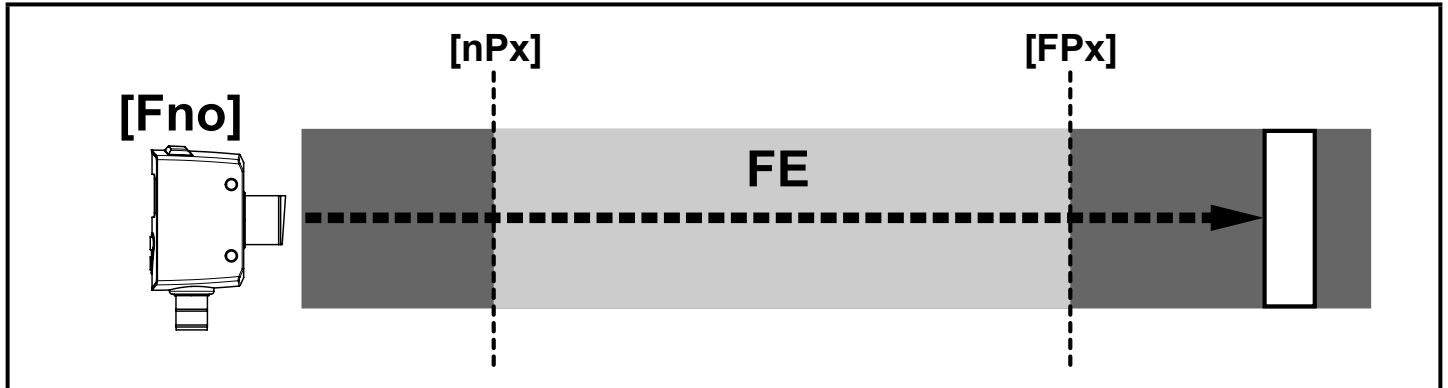

[nPx] = switch point "near"; [FPx] = switch point "far"; FE = window

If the measured value is between the switch point "near" [nPx] and the switch point "far" [FPx], the output is closed (when [OUx] = [Fno]).

Switches off when the object is detected

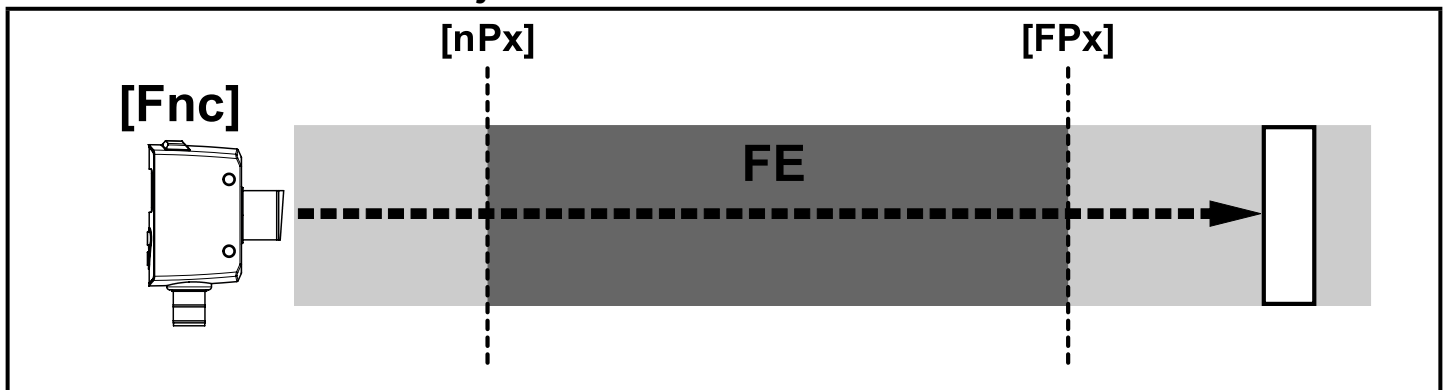

[nPx] = switch point "near"; [FPx] = switch point "far"; FE = window

If the measured value is between the switch point "near" [nPx] and the switch point "far" [FPx], the output is open (when [OUx] = [Fnc]).



The parameters [nP1] and [FP1] can also be set via the teach function. The reset points are set dynamically by the sensor → 10.2.7 Dynamic hysteresis.



The minimum distance between [nP1] and [FP1] is 1 mm.

Condition: $nP1 < FP1$

The teaching of $nP1 > FP1$ will not be adopted by the sensor.

Switching status of the outputs

Output function	Object distance (D)	Switching status
[Fno]	D < [nP _x] D > [FP _x]	Open
	[nP _x] < D < [FP _x]	Closed
[Fnc]	D < [nP _x] D > [FP _x]	Closed
	[nSP _x] < D < [FSP _x]	Open

Both window limit values ([nP_x] and [FP_x]) work with a switching hysteresis
 → 10.2.4 Hysteresis function example for output function [Hno].

UK

10.2.9 Setting of the switch points for window function OUT1 / OUT 2

<ul style="list-style-type: none"> ▶ Change to [EF]. ▶ In [OU1] select the output function [Fno] or [Fnc]. ▶ Confirm with [ENTER]. ▶ Select [nP1] and set the switch point "near". ▶ Confirm with [ENTER]. ▶ Select [FP1] and set the switch point "far". ▶ Confirm with [ENTER]. 	OU 1 OU 2 nP 1 FP 1
--	------------------------------

10.2.10 Teach - Setting of the switch point for window function OUT1 / OUT2

<ul style="list-style-type: none"> ▶ Change to [EF]. ▶ In [OU1] select the output function [Fno] or [Fnc]. ▶ Confirm with [ENTER]. ▶ Change to [EF] and select [tn1]. > Parameter value for [nP1] is displayed. ▶ Press the "up" or "down" button and keep it pressed. > The parameter value flashes for 3 s. > New parameter value is displayed. ▶ Confirm with [ENTER]. ▶ Change to [EF] and select [tF1]. > Parameter value for [FP1] is displayed. ▶ Press the "up" or "down" button and keep it pressed. > The parameter value flashes for 3 s. > New parameter value is displayed. ▶ Confirm with [ENTER]. 	OU 1 OU 2 tn 1 tF 1 nP 1 FP 1
---	--

10.3 Extended functions

10.3.1 Setting of the delay time for switching outputs

<ul style="list-style-type: none">▶ Change to [EF].▶ Select a parameter with the "up" or "down" button: [dSx] = switch-on delay; [drx] = switch-off delay.▶ Set the parameter value with [Enter]:<ul style="list-style-type: none">> Set parameter value is displayed.▶ Keep the "up" or "down" button pressed for at least 3 s.<ul style="list-style-type: none">> Parameter value flashes.▶ Set the parameter value by means of the "up" or "down" button. Setting range [s]: 0 / 0.1...5 s in steps of 0.1 s (0 = delay time is not active)▶ Confirm with [ENTER].	<pre>EF dS1 dr1 dS2 dr2</pre>
--	-------------------------------

10.3.2 Setting of the fault suppression time for switching outputs

<ul style="list-style-type: none">▶ Change to [EF].▶ Select the parameter [dFo] with the "up" or "down" button:▶ Set the parameter value with [Enter]:<ul style="list-style-type: none">> Set parameter value is displayed.▶ Keep the "up" or "down" button pressed for at least 3 s.▶ Parameter value flashes.▶ Set the parameter value by means of the "up" or "down" button. Setting range [s]: 0 / 0.1...5 s in steps of 0.1 s▶ Confirm with [ENTER].	<pre>EF dFo</pre>
--	-------------------

10.3.3 Reset of all parameters to factory setting

<ul style="list-style-type: none">▶ Change to [EF].▶ Select [rES] with the "up" or "down" button, then press [Enter].<ul style="list-style-type: none">> [rE] is displayed.▶ Keep the "up" or "down" button pressed until [---] is displayed.<ul style="list-style-type: none">> All parameters are reset to factory setting.	<pre>EF rES</pre>
---	-------------------

11 IO-Link

11.1 General information

This unit has an IO-Link communication interface which requires an IO-Link-capable module (IO-Link master) for operation.

The IO-Link interface enables direct access to the sensor values and parameters and provides the possibility to set the parameters of the unit during operation.

In addition, communication is possible via a point-to-point connection with a USB adapter cable.

You will find more detailed information about IO-Link at www.ifm.com.

11.2 Device-specific information

You will find the IODDs necessary for the configuration of the IO-Link device and detailed information about sensor values, diagnostic information and parameters in the overview table at www.ifm.com.

11.3 Parameter setting tools

You will find all necessary information about the required IO-Link hardware and software at www.ifm.com.

11.4 Functions

With IO-Link all functions and measured data are available that can also be accessed via the display and pushbuttons on the unit.

The process data value includes the measuring distance and the object reflectivity. All functions are described in detail in the IODD.

UK

12 Set-up / operation

- ▶ After installation, electrical connection and programming, check whether the unit operates correctly.
- > If the unit has been correctly set up, the distance to the object is indicated.



Lifetime of a laser diode: 50000 hours

12.1 Error indications

Display	Possible cause	Switching output			
		[Hno]	[Hnc]	[Fno]	[Fnc]
[- +]	Too much light, e.g. reflective surface	ON	OFF	OFF	ON
[--]	Not enough light, no object	OFF	ON	OFF	ON
[nEA]	Object to be measured outside the measuring range < 25 mm	ON	OFF	OFF	ON
[FAr]	Object to be measured outside the measuring range > 165 cm	OFF	ON	OFF	ON
[OFF]	Laser is switched off	OFF	ON	OFF	High

Display	Possible cause	Switching output			
		[Hno]	[Hnc]	[Fno]	[Fnc]
[Erp]	Plausibility (e.g. object too fast)	X ¹⁾	X ¹⁾	X ¹⁾	X ¹⁾
[SC]	Short circuit in all switching outputs				

¹⁾Unchanged

13 Maintenance, repair and disposal

Faulty sensors must only be repaired by the manufacturer.

- ▶ Keep the front lens of the sensor clean.
- ▶ After use dispose of the unit in an environmentally friendly way in accordance with the applicable national regulations.
- ▶ Do not try to open the module enclosure. There are no user-serviceable components inside.

14 Scale drawing

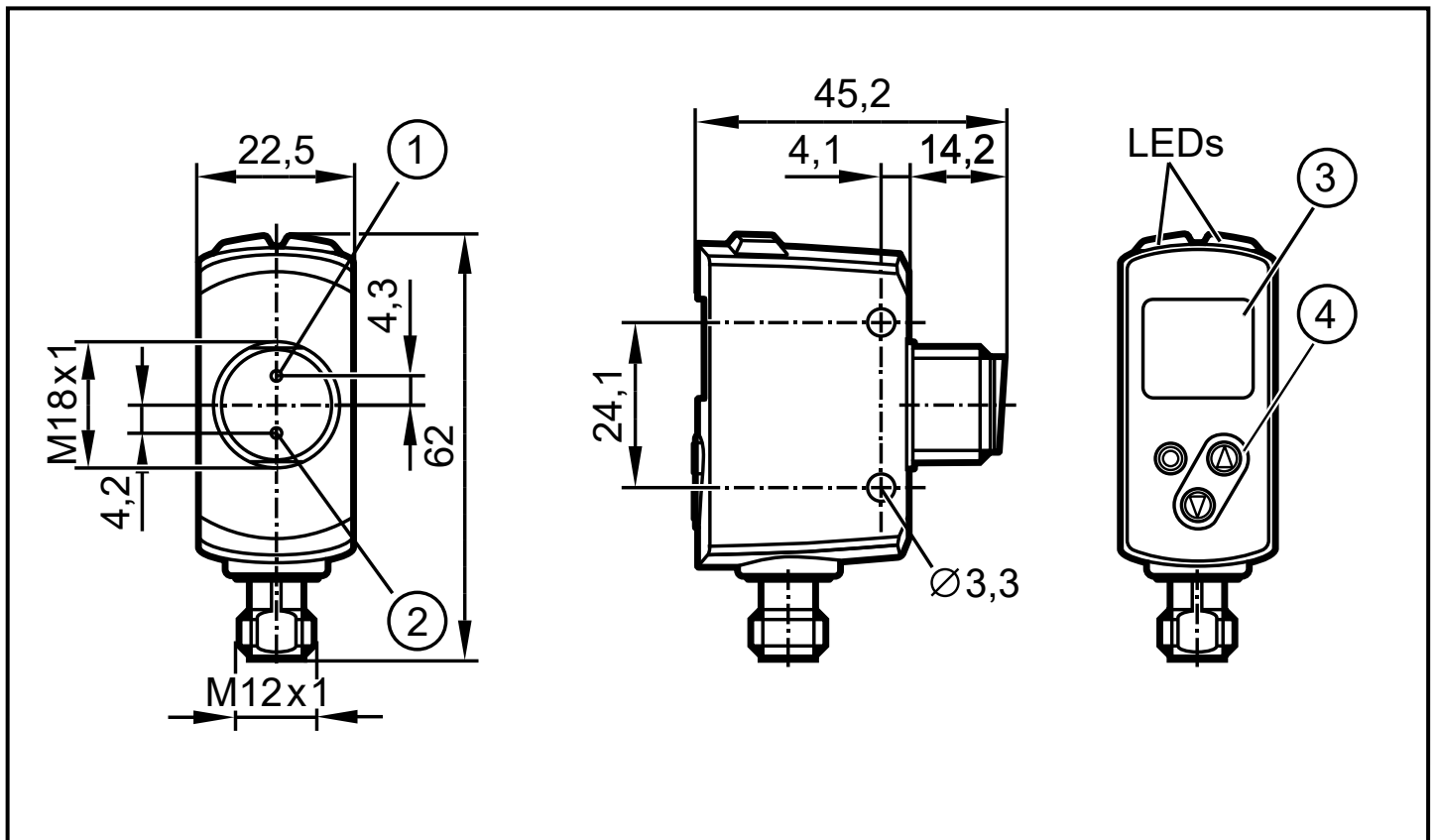

Dimensions in mm

- 1: receiving element
- 2: transmitting element
- 3: 3-digit alphanumeric display / LED function display
- 4: Programming buttons

15 Factory setting

Parameter	Setting range	Factory setting	Own setting
Uni	cm, inch	cm	
OU1	Hno, Hnc, Fno, Fnc	Hno	
SP1	3,0...150	150	
nP1	3,0...150	20	
FP1	3,0...150	25	
OU2	Hno, Hnc, Fno, Fnc, OFF	Hno	
SP2	3,0...150	3,0	
nP2	3,0...150	30	
FP2	3,0...150	35	
dS1	0...0.1...5	0 s	
dr1	0...0.1...5	0 s	
dS2	0...0.1...5	0 s	
dr2	0...0.1...5	0 s	
dFo	0...0.1...5	0.1 s	
diS	On / OFF	On	

UK