

CE

Operating instructions
Through-beam sensor
O6E7xx / O6S7xx

UK

706460 / 00 04 / 2019

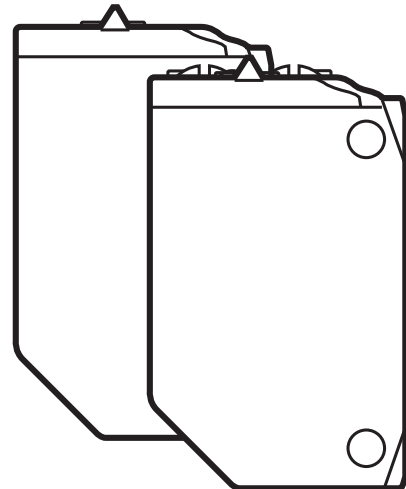

Contents

1	Preliminary note.....	2
1.1	Symbols used	2
2	Safety instructions	3
3	Functions and features	4
4	Installation.....	4
5	Operating and display elements	5
5.1	Stability indication.....	5
6	Electrical connection.....	6
6.1	Transmitter.....	6
6.2	Receiver.....	6
6.2.1	PNP	6
6.2.2	NPN	7
7	Settings.....	8
7.1	Settings on the sensor	8
7.1.1	The sensor is to switch when the object is detected	8
7.1.2	The sensor is not to switch when the object is detected	9
7.1.3	Setting the maximum sensitivity	9
7.1.4	Programming unsuccessful	9
7.1.5	Electronic lock	9
7.2	Setting via IO-Link	9
7.2.1	Adjustable parameters.....	10
7.2.2	Set the sensitivity with object.....	12
7.2.3	Setting the maximum sensitivity	12
8	Operation	13
9	Maintenance, repair, disposal.....	13

1 Preliminary note

Technical data, approvals, accessories and further information at www.ifm.com.

1.1 Symbols used

► Instructions

- > Reaction, result
- [...] Designation of keys, buttons or indications
- Cross-reference



Information

Supplementary note.



Important note

Non-compliance may result in malfunction or interference.

2 Safety instructions

UK

- Read this document before setting up the product and keep it during the entire service life.
- The product must be suitable for the corresponding applications and environmental conditions without any restrictions.
- Only use the product for its intended purpose (→ 3 Functions and features).
- If the operating instructions or the technical data are not adhered to, personal injury and/or damage to property may occur.
- The manufacturer assumes no liability or warranty for any consequences caused by tampering with the product or incorrect use by the operator.
- Installation, electrical connection, set-up, operation and maintenance of the product must be carried out by qualified personnel authorised by the machine operator.
- Protect units and cables against damage.

According to cULus



Caution - Use of controls or adjustments or procedures other than those specified herein may result in hazardous radiation exposure.



Visible laser light; LASER CLASS 1.

EN/IEC 60825-1 : 2007 and EN/IEC 60825-1 : 2014

Complies with 21 CFR 1040 except for deviations

pursuant to Laser Notice No. 50, dated June 2007.

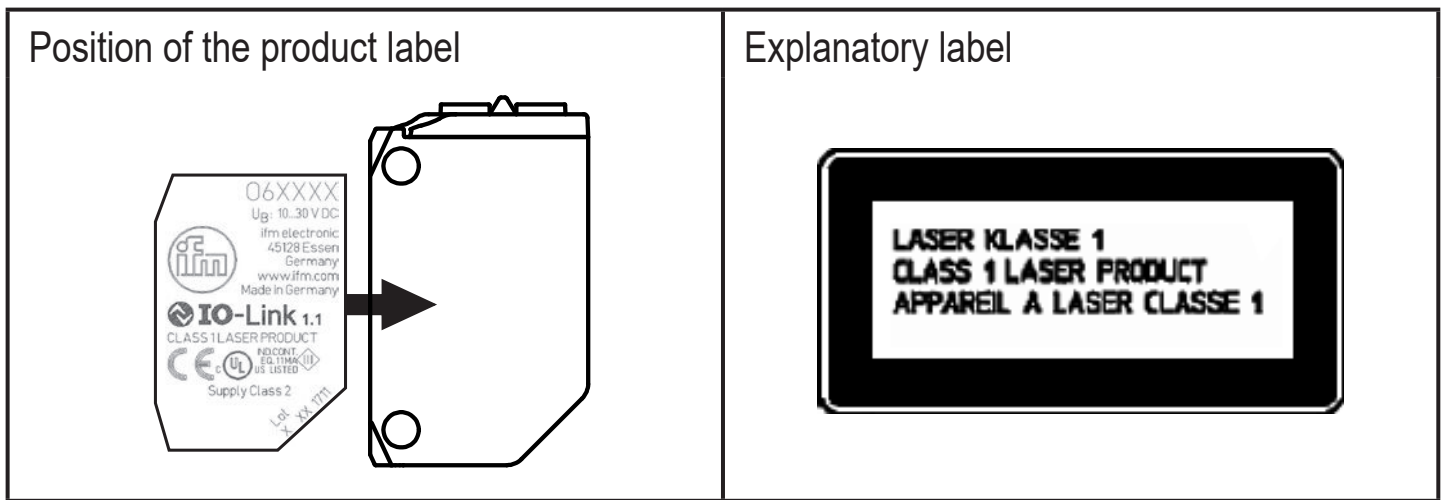

3 Functions and features

The through-beam sensor detects objects and materials without contact and indicates their presence by a switching signal.

4 Installation

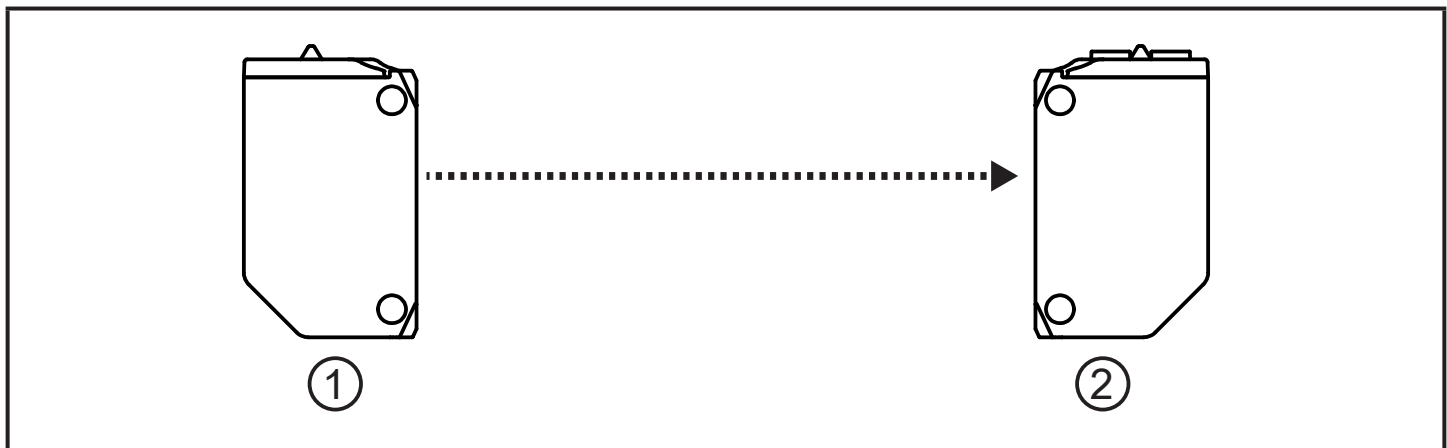

1: Transmitter

2: Receiver

- ▶ Secure the receiver (O6E ...) to a bracket.
- ▶ Align the transmitter (O6S ...) to the receiver and secure it in the same way.



Maximum range only with accurate alignment.

5 Operating and display elements

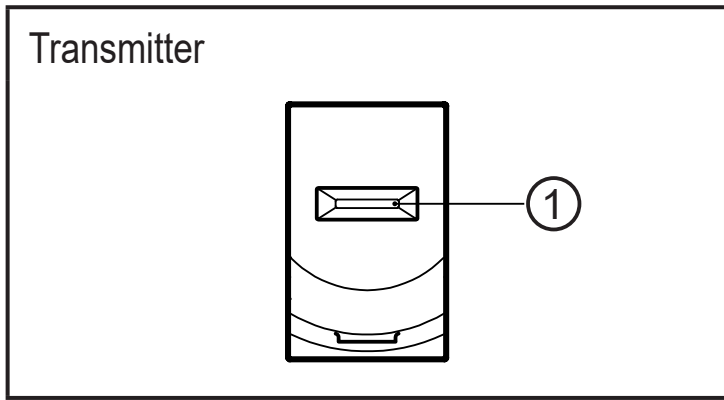

1: LED green - operation

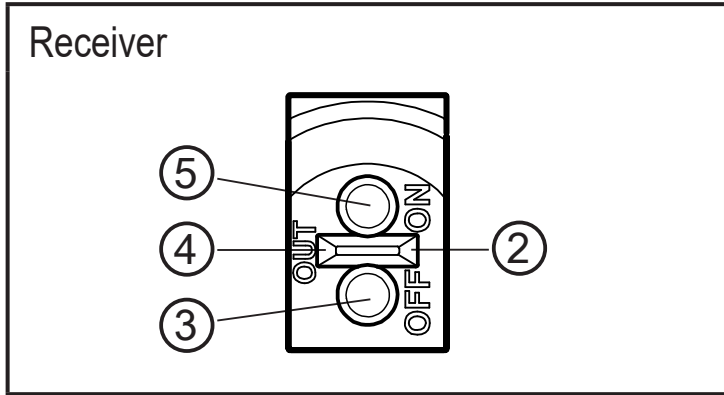

2: LED green - operation, stability indication

3: OUT OFF button





4: LED yellow - switching output active

5: OUT ON button

UK

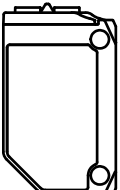
5.1 Stability indication

The green LED is on when the supply voltage is applied and the sensor signal is stable.

	Stable signal	Switch point	Stable signal
			
Light-on mode			
LED green	on	off	on
LED yellow	on	on	off
Dark-on mode			
LED green	on	off	on
LED yellow	off	off	on

6 Electrical connection



The unit must be connected by a qualified electrician.

- ▶ The national and international regulations for the installation of electrical equipment must be adhered to.
- ▶ Ensure voltage supply to EN 50178.

▶ Disconnect power.

▶ Connect the unit as follows:

6.1 Transmitter

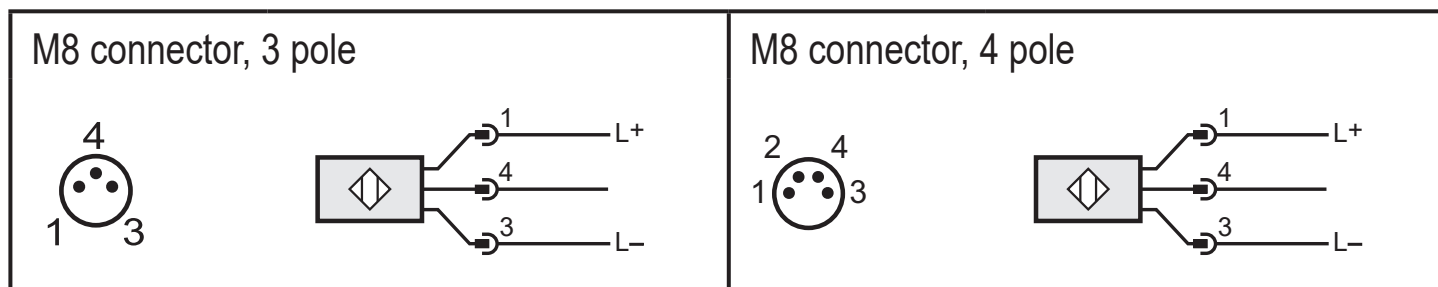
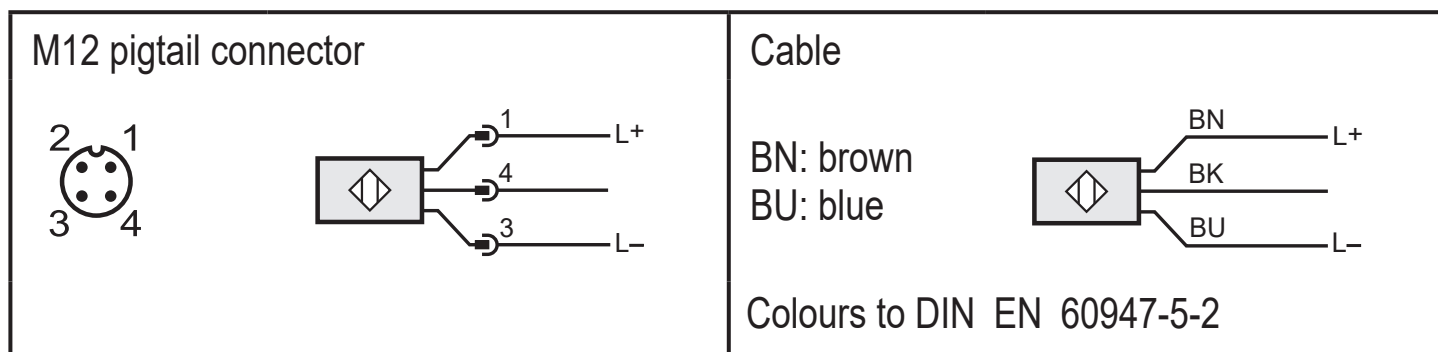

6.2 Receiver

6.2.1 PNP

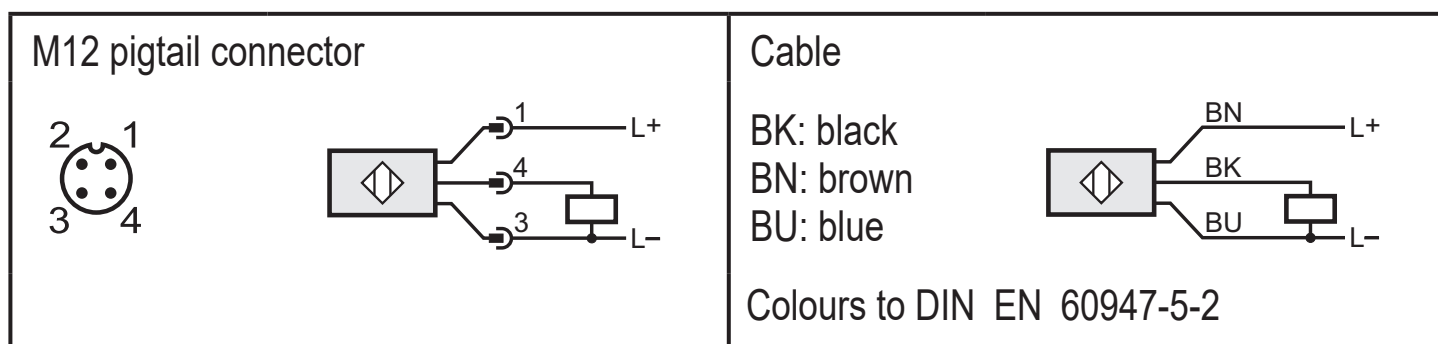

M8 connector, 3 pole

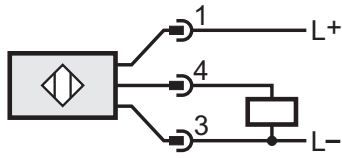

M8 connector, 4 pole

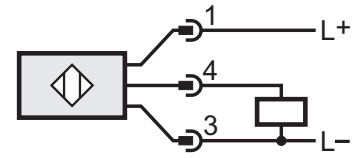

6.2.2 NPN

M12 pigtail connector

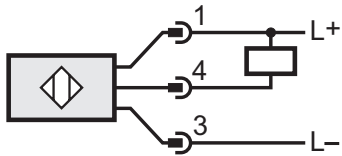

Cable

BK: black
BN: brown
BU: blue

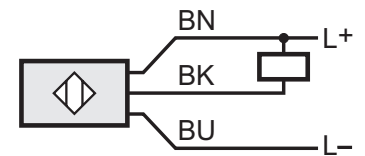

Colours to DIN EN 60947-5-2

UK

M8 connector, 3 pole

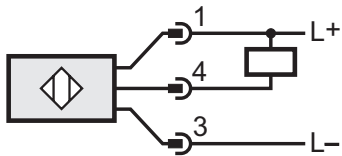

M8 connector, 4 pole

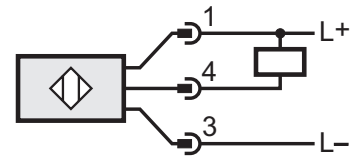
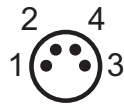

7 Settings

7.1 Settings on the sensor

7.1.1 The sensor is to switch when the object is detected

- ▶ Position object (Fig. 1).
- ▶ Press [OUT ON] for > 2 s.
- > The yellow LED flashes.
- > The setting of the sensitivity with object is made by releasing [OUT ON].
- ▶ Remove object (Fig. 2).
- ▶ Press [OUT OFF].
- > The setting of the sensitivity without object is made by releasing [OUT OFF].
- > The yellow LED goes out. Programming is completed.

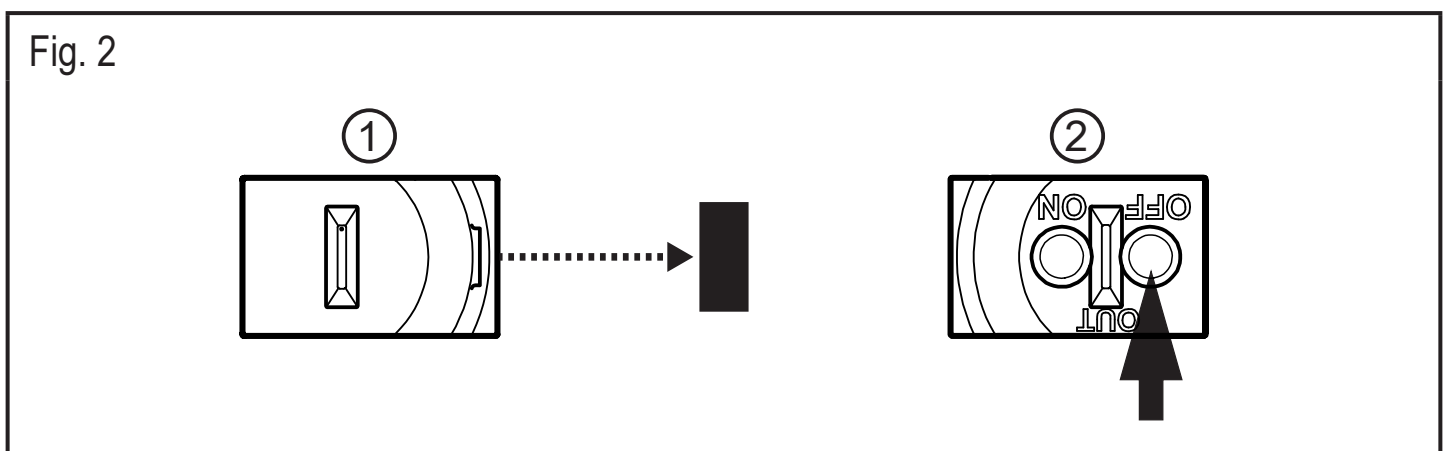
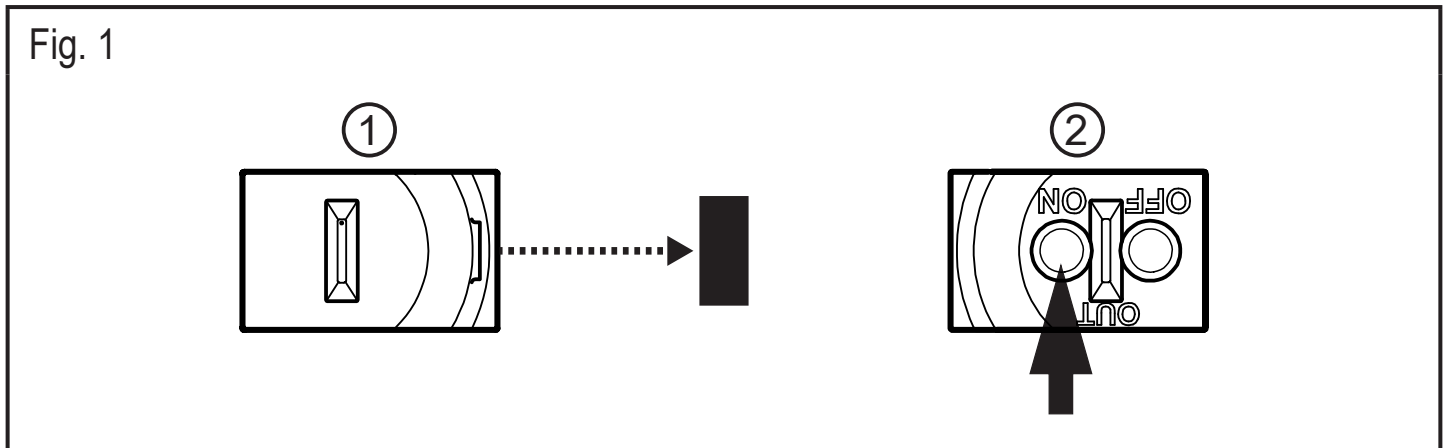

- 1: Transmitter
- 2: Receiver

7.1.2 The sensor is not to switch when the object is detected

- ▶ Position the object (see Fig. 1) and press [OUT OFF] for > 2s.
- ▶ Remove the object (see Fig. 2) and press [OUT ON].



The settings can also be carried out first without object and then with object.

7.1.3 Setting the maximum sensitivity

- ▶ Align the object so that no light is received.

1. The sensor is to switch when the object is detected

- ▶ Press [OUT ON] for > 2 s, then [OUT OFF].

2. The sensor is not to switch when the object is detected

- ▶ Press [OUT OFF] for > 2 s, then [OUT ON].

7.1.4 Programming unsuccessful

- > The LED flashes quickly, 8 Hz.
 - Insufficient difference in measurements.
 - Max. programming time (15 min.) exceeded.

7.1.5 Electronic lock

Lock or unlock the buttons

- ▶ Press [OUT ON] and [OUT OFF] simultaneously for 10 s.
- > Acknowledgement is indicated by a brief change of the LED switching status.

7.2 Setting via IO-Link

This unit has an IO-Link communication interface which enables direct access to process and diagnostic data. In addition it is possible to set the parameters of the unit while it is in operation. Operation of the unit via an IO-Link interface requires an IO-Link master.

With a PC, suitable IO-Link software and an IO-Link adapter cable communication is possible when the system is not in operation.

The IO-DDs necessary for the configuration of the unit, detailed information about process data structure, diagnostic information, parameter addresses and the necessary information about the required IO-Link hardware and software can be found at www.ifm.com.

7.2.1 Adjustable parameters

Among others, the following parameters can be set via IO-Link.



A table of all adjustable parameters can be found at www.ifm.com/de/io-link.

Parameters for the receiver (O6E7xx)

Parameter name	Values	Description	Standard setting
SSC1 Param. SP1	1 ... 100	Setting switch point in step increment "1". After a teach process the resulting value is displayed.	100
Teach SP1 TP1		1. Part of the teach sequence to set switch point SP1 by teach on object. Both parts of the teach sequence for TP1 and TP2 (TP = teach point) have to be carried out.	N. A.
Teach SP1 TP2		2. Part of the teach sequence to set switch point SP1 by teach without object. The second part of the teach sequence has to be carried out after the first part.	N. A.
TI Result.State	- Idle - SP1 Success - Wait for command - Busy - Error - Custom	Teach-in status; after successful teach the value "SP1 Success" is displayed.	N. A.
SSC1 Config. Logic	High active Low active	Switch point logic, status for detected object (High: light-on mode / normally open, Low: dark-on mode / normally closed)	→ Data sheet value "Output function"
SSC1 switch-on delay	0 ... 2	Start-up delay; step increment 0.1 s	0
SSC1 switch-off delay	0 ... 2	Switch-off delay; step increment 0.1 s	0
Excess gain	0 ... 5	Excess gain at receiver.	N. A.
Number of power cycles	0 ... 65535	Number of switching operations (power up) of the sensor	N. A.

Parameter name	Values	Description	Standard setting
Operating hours	0 ... 65535	Operating hours	N. A.

Parameters for the transmitter (O6E7xx)

Parameter name	Values	Description	Standard setting
Transmitter configuration	- On - Off	Configuration transmitted light on / off	On
Number of power cycles	0 ... 65535	Number of switching operations (power up) of the sensor	N. A.
Operating hours	0 ... 65535	Operating hours	N. A.

UK

7.2.2 Set the sensitivity with object

- ▶ Start the LR DEVICE software.
- ▶ Align the transmitter to the object (Fig. 1).
- ▶ Press [Teach SP1 TP1] in the LR DEVICE software.
- ▶ Align the receiver to the transmitter (Fig. 2).
- ▶ Press [Teach SP1 TP2] in the LR DEVICE software.

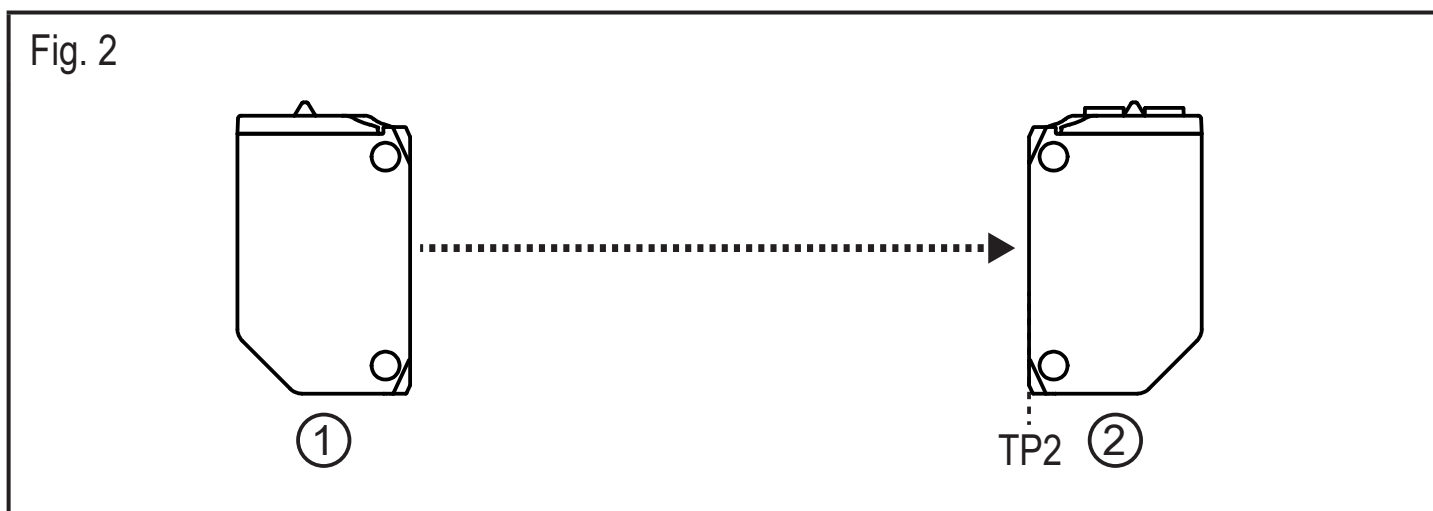
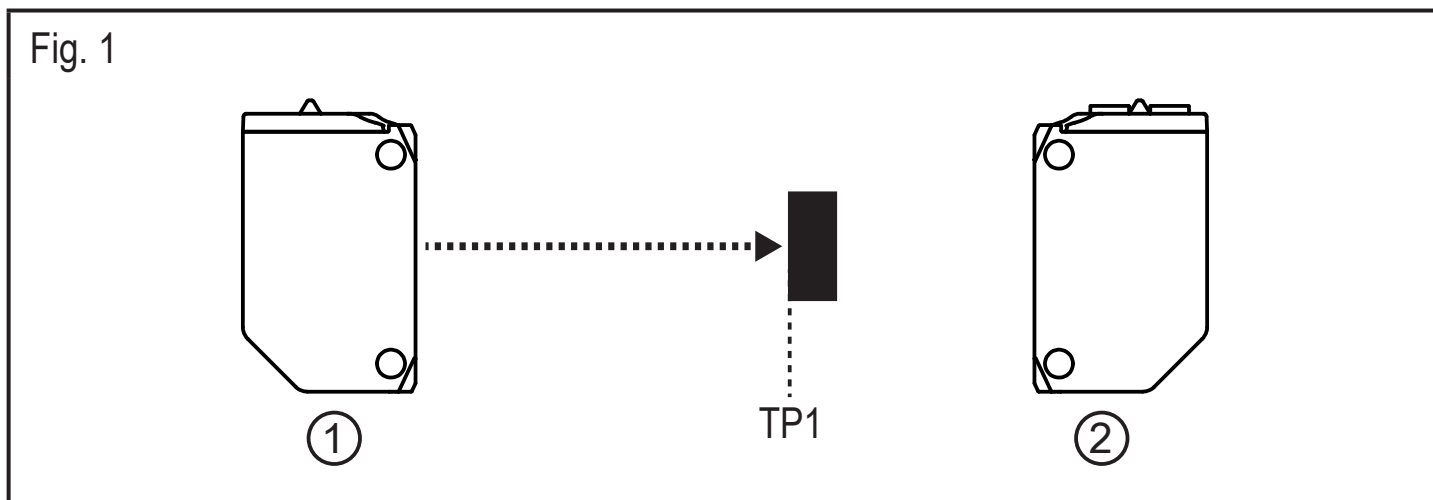

1: transmitter; 2: receiver; TP1: teach point 1; TP2: teach point 2

 Either the object can be set first and then the background, or the other way around.

7.2.3 Setting the maximum sensitivity

- ▶ Start the LR DEVICE software.
- ▶ Align the object so that no light is received.
- ▶ Press [Teach SP1 TP1] in the LR DEVICE software.
- ▶ Press [Teach SP1 TP2] in the LR DEVICE software.

8 Operation

- ▶ Check whether the unit operates correctly.
- > The green LED is on when the unit is ready for operation.
- > Setting the dark-on mode: The output is switched / the yellow LED is on when no object is detected.
- > Setting the light-on mode: The output is switched / the yellow LED is on when an object is detected.

9 Maintenance, repair, disposal

- ▶ Keep the lens of the sensor free from soiling.
- ▶ For cleaning do not use any solvents or cleaning agents which could damage the plastic parts.
- ▶ After use dispose of the unit in an environmentally friendly way in accordance with the applicable national regulations.

Faulty sensors must only be repaired by the manufacturer.