

ifm electronic



Operating instructions  
AS-i CompactLine module

**ecomat300<sup>®</sup>**

**AC2403**

**UK**

7390950/00 08/2012

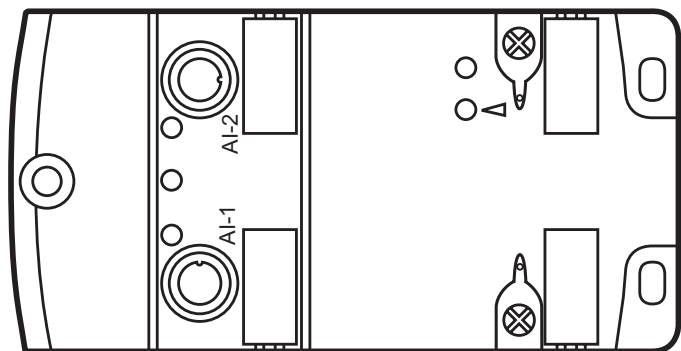

# Contents

|   |   |
|---|---|
| 1 Preliminary note.....                             | 3 |
| 2 Safety instructions .....                         | 3 |
| 3 Functions and features .....                      | 3 |
| 4 Operating and display elements .....              | 4 |
| 5 Installation.....                                 | 4 |
| 6 Addressing.....                                   | 6 |
| 6.1 Addressing with the AC1154 addressing unit..... | 6 |
| 6.2 Infrared addressing.....                        | 6 |
| 7 Electrical connection.....                        | 6 |
| 7.1 Current measurement.....                        | 7 |
| 8 Parameter setting .....                           | 8 |
| 9 Measuring range of the module.....                | 8 |
| 10 Operation.....                                   | 9 |
| 11 Maintenance, repair and disposal .....           | 9 |
| 12 Technical data.....                              | 9 |

# 1 Preliminary note

► Instructions

> Reaction, result



Important note

Non-compliance can result in malfunction or interference.



Information

Supplementary note.

## 2 Safety instructions

- Please read the operating instructions prior to set-up of the unit. Ensure that the product is suitable for your application without any restrictions.
- The unit conforms to the relevant regulations and EC directives.
- Improper or non-intended use may lead to malfunctions of the unit or to unwanted effects in your application.
- Installation, electrical connection, set-up, operation and maintenance of the unit must only be carried out by qualified personnel authorised by the machine operator.

## 3 Functions and features

The slave converts analogue input signals and transfers them to the AS-i master via the AS-Interface. The AS-i module operates as a slave with bidirectional data transfer in the AS-i network.

The data transfer to the host is asynchronous according to the AS-i profile S-7.3.D and the AS-i specification 3.0, downward compatible.

- maximum number of modules per master: 31
- Current measurement 4...20 mA
- Time for converting the measured values in the slave
  - for one channel: 60 ms
  - for two channels: 120 ms

## 4 Operating and display elements

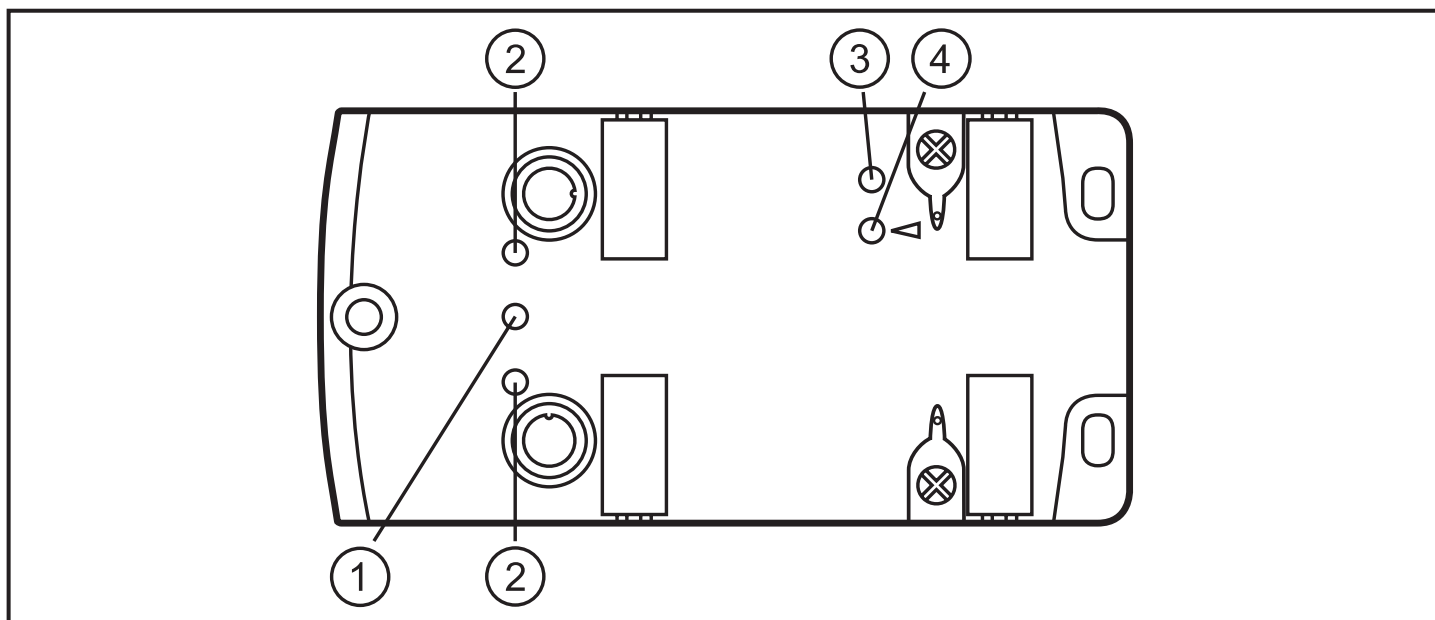

- 1: LED AS-i
- 2: LED AI
- 3: LED IR addressing
- 4: LED FAULT

## 5 Installation



▶ Disconnect the system from power before installation.



▶ For installation choose a flat mounting surface. The entire bottom of the module must lie flat on the mounting surface.

- ▶ Screw the lower part onto the mounting surface using M4 screws and flat washers (1). Tightening torque 1.8 Nm.
- ▶ Carefully place the yellow AS-i flat cable into the profile slot.
- ▶ Position the upper part and fix it using the supplied M3.5 (2) screws. Tightening torque 1.2...1.4 Nm.
- ▶ Fix the module onto the mounting surface using M4...M5 screw and washer (4). Tightening torque max. 1.8 Nm. Use stainless steel sleeve (E70402)\* for installation in case of high mechanical stress.  
\*to be ordered separately
- ▶ Connect the plugs of the sensors (5) to the M12 sockets. Tightening torque 0.8...1.5 Nm.
- ▶ Cover the unused sockets with the supplied protective caps (E73004). Tightening torque 0.6...0.8 Nm.

- ▶ Use the supplied flat cable end seal (E70413) if the module is at the end of the cable line.



In case of interference coupling to the sensor cables the use of the functional earth springs can improve the EMC.

Prerequisite: An interference-free and low-resistance connection to the machine ground.

- ▶ If necessary, you can ground the module via the earth springs (3).

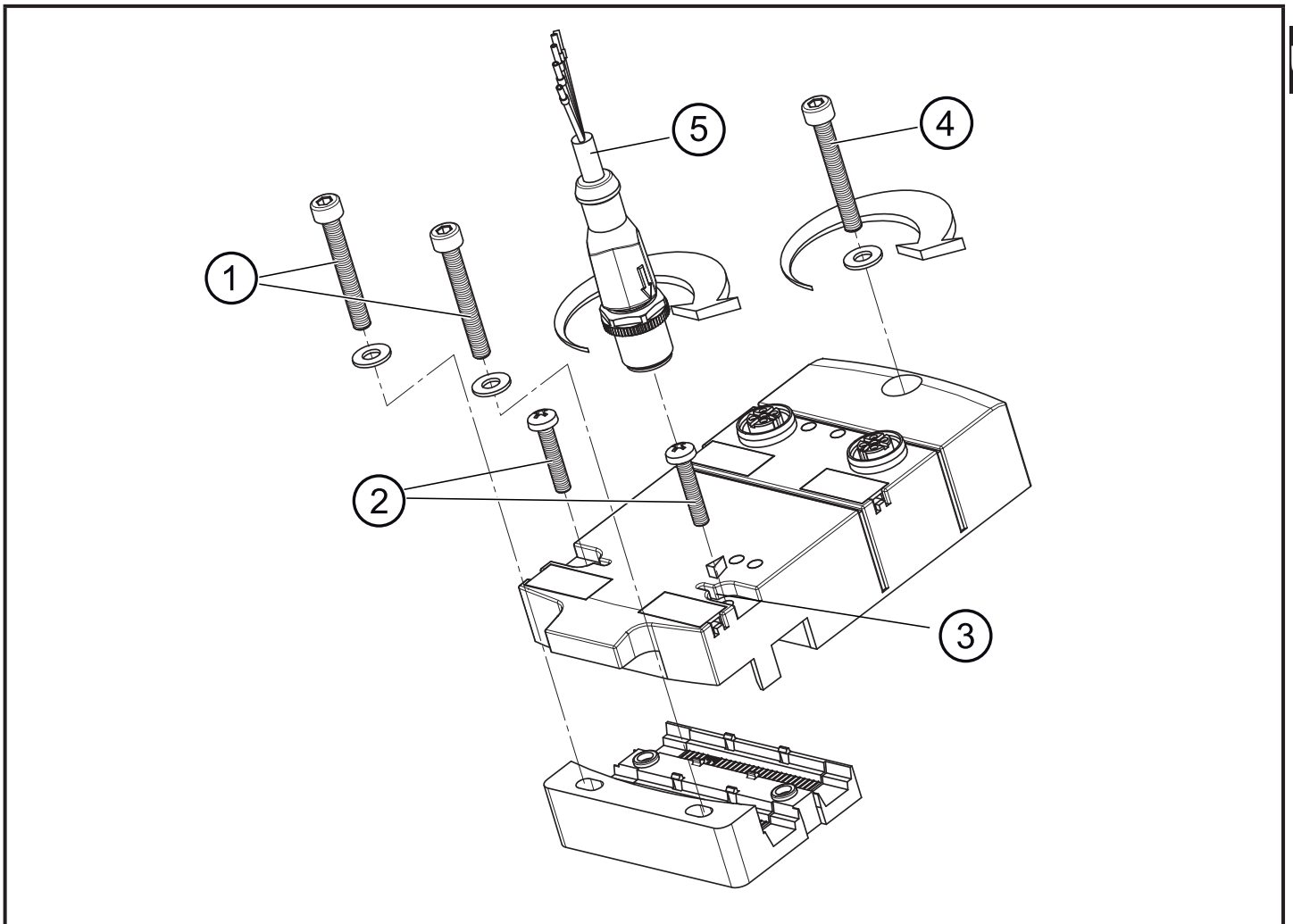

- 1: M4 screws and washers (not supplied with the device). Tightening torque 1.8 Nm.
- 2: M3.5 screws supplied. Tightening torque 1.2...1.4 Nm.
- 3: Functional earth springs
- 4: M4...M5 screw and washer (not supplied with the device). Tightening torque max. 1.8 Nm.
- 5: M12 connector. Tightening torque max. 0.8...1.5 Nm.



Observe the maximum tightening torque of the connection cable.

## 6 Addressing

- ▶ Assign a free address between 1 and 31.

The address is set to 0 at the factory.

### 6.1 Addressing with the AC1154 addressing unit

When mounted and wired the module can be addressed with the addressing cable (E70423) via the integrated addressing interface.

### 6.2 Infrared addressing

The safe AS-i module also offers the option of infrared addressing with the addressing unit AC1154 and the addressing cable E70211.



The AS-i communication (yellow cable) must be switched off during the infrared addressing.

- ▶ Disconnect the master.
- ▶ Supply the slaves with voltage via the AS-i power supply.



When the ifm AS-i power supplies type SL are used, the communication can be deactivated via a jumper on the power supply.

## 7 Electrical connection



The unit must be connected by a qualified electrician.

The national and international regulations for the installation of electrical equipment must be adhered to.

- ▶ Disconnect power.
- ▶ Connect the plugs of the sensors / actuators to the M12 sockets.
- ▶ Connect the unit.

## 7.1 Current measurement

In all the following wiring diagrams the indicated pin connection refers to the unit.

Wiring of a 2-wire sensor with own (grounded) supply

- 1: Sensor supply +24 V
- 2: Analogue input AI +
- 3: Sensor supply 0 V
- 4: Analogue input AI -
- 5: Functional earth FE

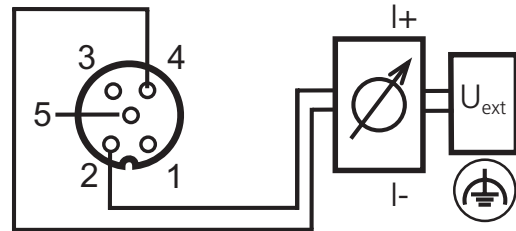

Connection of a 2-wire sensor without own supply

- 1: Sensor supply 24 V
- 2: Analogue input AI +
- 3: Sensor supply 0 V
- 4: Analogue input AI -
- 5: Functional earth FE

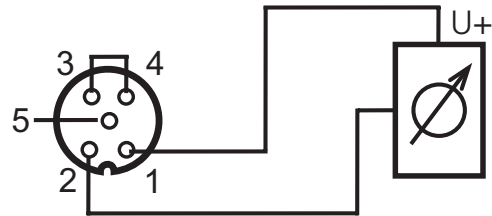

Connection of a 3-wire sensor without own supply

- 1: Sensor supply 24 V
- 2: Analogue input AI +
- 3: Sensor supply 0 V
- 4: Analogue input AI -
- 5: Functional earth FE

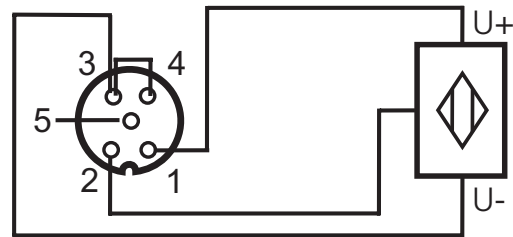

When connecting a 2-wire or 3-wire sensor without own supply there has to be an external link between pin 3 and pin 4.

Connection of a 4-wire sensor without own supply

- 1: Sensor supply 24 V
- 2: Analogue input AI +
- 3: Sensor supply 0 V
- 4: Analogue input AI -
- 5: Functional earth FE

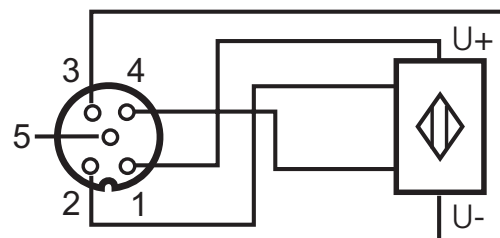

UK

## 8 Parameter setting

| Parameter bit / Designation | Description |  | Comments  |
|-----------------------------|-------------|--|---|
| P0 filter                   | 1*          | 50 Hz filter in the A/D converter active | The 50 Hz filter applies to the whole of Europe.  |
|                             | 0           | 60 Hz filter in the A/D converter active |   |
| P1 channel 2                | 1           | Channel 2 enabled                        | The configuration has an effect on the conversion time in the AS-i slave, the transmission via the AS-Interface, the LED function and the peripheral fault messages. LED indication and peripheral fault messages are then no longer influenced by this channel. By disabling channel 2 the conversion time in the slave can be reduced considerably. |
|                             | 0           | Channel 2 not enabled                    |   |
| P2 periphery fault          | 1           | Periphery fault active                   | * default setting   |
|                             | 0           | Periphery fault not active               |   |
| P3 not used                 | 1           | reserved                                 |   |
|                             | 0           | reserved                                 |   |

## 9 Measuring range of the module

For the measuring range and its significance please refer to the following tables:

| Range [mA] | Units dec.              | Units hex.           | LED     | Peripheral fault | Meaning                      |
|------------|-------------------------|----------------------|---------|------------------|------------------------------|
| < 3.4      | 32768 → 32767 *         | 8000 → 7FFF *        | flashes | on***            | wire break                   |
| 3.4...3.59 | 3400...3599 → 32767 *   | 0D48...0E0F → 7FFF * | flashes | off              | below nominal range          |
| 3.6...22   | 3600.. 22000            | 0E10.. 55F0          | on      | off              | extended and nominal range** |
| 22.01...23 | 22001...23000 → 32767 * | 55F1.. 59D8 → 7FFF * | flashes | off              | above nominal range          |



|      |       |      |         |       |               |
|------|-------|------|---------|-------|---------------|
| > 23 | 32767 | 7FFF | flashes | on*** | outside range |
|------|-------|------|---------|-------|---------------|

Note:

\* the master replaces the value transmitted by the slave with the default value 7FFFh (32767)

\*\* the accuracy is only achieved in the nominal range (4...20 mA), it is not guaranteed in the extended nominal range.

\*\*\* only for parameter bit 2 = 1

UK

## 10 Operation

Check whether the unit operates correctly. Display by LEDs:

|                        |   |
|------------------------|---|
| LED AI yellow off:     | Sensor input is deactivated<br>(see parameter bit P1)                 |
| LED AI yellow on:      | Analogue signal in the measuring range                                |
| LED AI yellow flashes: | Analogue signal outside the measuring range or<br>no sensor connected |
| LED green PWR on:      | AS-i voltage is applied   |
| LED red FAULT on:      | AS-i communication error  |
| LED red FAULT flashes: | Periphery fault*  |

\* A periphery fault is displayed:

- if at least one of the analogue signals is outside the value range
- if nothing is connected to at least one analogue channel although the respective channel (P2) is enabled
- in case of overload or short circuit of the sensor supply

## 11 Maintenance, repair and disposal

The operation of the unit is maintenance-free. After use dispose of the unit in an environmentally friendly way in accordance with the applicable national regulations.

## 12 Technical data

Technical data and further information at [www.ifm.com](http://www.ifm.com)