

Installing the RFID Controller

1. Attach the controller to the mounting bracket using the two sets of M4 screws, washers and nuts provided. Place the nuts in each of the hex-shaped recessed cavities at the rear of the Unit.
2. Align the mounting bracket with the two mounting holes on the controller, then insert both M4 screws (with washers) into the controller from the underside and secure completely using a standard Phillips #2 head screwdriver. Tighten screws to 0.7 Nm (6 lbs / inch) $\pm 10\%$.
3. Fasten the other end of the mounting bracket to your work area. The Unit may be mounted horizontally or vertically, but should be aligned in such a manner that the LED indicators can be seen during operation.
4. Download the USB driver software bundle from the Balluff website (www.balluff.com). Extract the .zip file archive to a separate folder on the desktop of the host computer.
5. Attach the 5-pin, reverse keyed female M12 interface connector from a suitable USB interface cable (CBL-1525) to the 5-pin, reverse keyed male M12 connector on the Unit.
6. Plug the remaining end of the USB interface cable into a USB port on the host computer. The LEDs on the controller will flash. At this point, Windows™ will detect the new hardware device and request the location of the USB driver files.
7. Browse to the folder containing the USB driver files. Refer to the "USB Driver Installation Instructions", included with the USB driver download, to complete the installation of the USB driver.
8. To verify operations, download the serial version of the HF Dashboard Utility. The HF Dashboard Utility allows users to configure and control their controllers and send RFID commands for testing purposes.

Figure 1: Controller, Mounting Bracket and Hardware

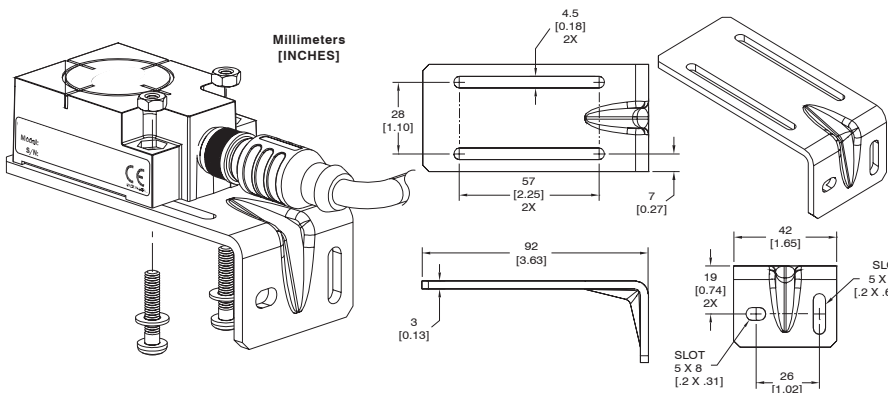
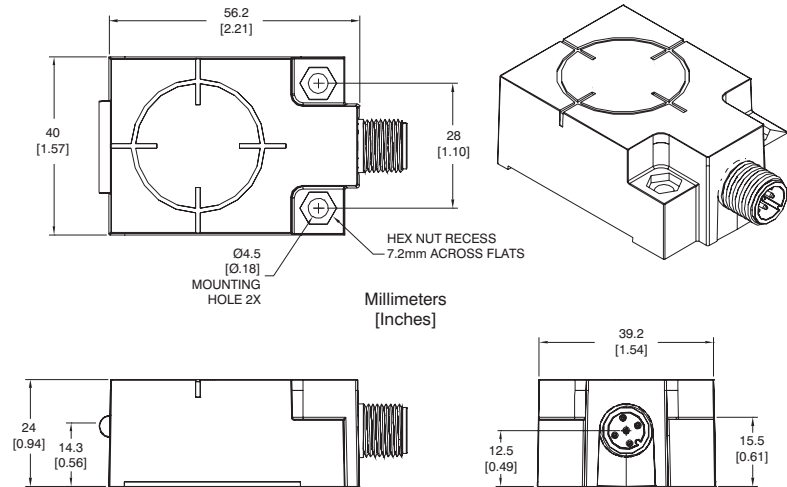

Figure 2: Dimensions



Power Requirements

The Unit obtains power directly from the USB bus and requires 250 mA.

Figure 3: Interface Connector - Pinout

The Balluff RFID Controller has one 5-pin, reverse keyed male M12 connector that is used for data and power.

Cabling Part Numbers

- **CBL-1514:** Connector (5-pin, reverse keyed male M12 connector for USB)
- **CBL-1525:** Cable (5-pin, reverse keyed female M12 to USB Type A, 3 m)

(XX = CABLE LENGTH IN METERS)

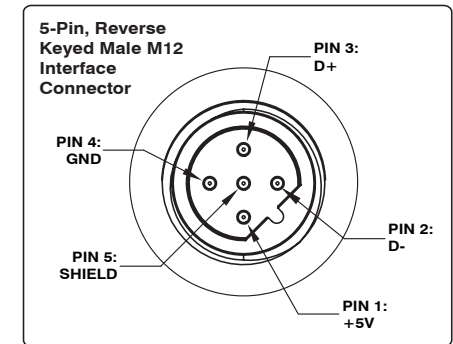

Installation Guidelines

- RFID devices can be negatively affected by the presence of metallic objects near its RF field. Avoid mounting the unit within 5 cm (two inches) of metallic surfaces.
- Locate the unit away from sources of EMI (electro-magnetic interference) and away from devices that generate high ESD (electro-static discharge) levels.
- Do not route the Unit's cables near unshielded cables or near wiring that is carrying high voltage or high current (such as for motors or solenoids). Cross cables only at perpendicular intersections.
- Use the included polycarbonate mounting bracket or a similar non-metallic bracket. The bracket is provided to help reduce electrically conducted spurious noise by isolating the RFID controller from metallic surfaces.
- If multiple RFID controllers operating at the same frequency (13.56 MHz) are to be installed, maintain a minimum distance of 20 cm (8 inches) between adjacent RF devices.