

# Retro-Reflex Sensor

## XN96VBH3 LASER

Part Number



- Single-lens optic
- Smallest recognizable part: 0,25 mm
- Switching frequency: 5 kHz
- Time delay

A reflector must be used in combination with these sensors. They can be installed in all kinds of industrial environments thanks to ample functional reserve. Even reflective objects can be reliably recognized through the use of polarized light.

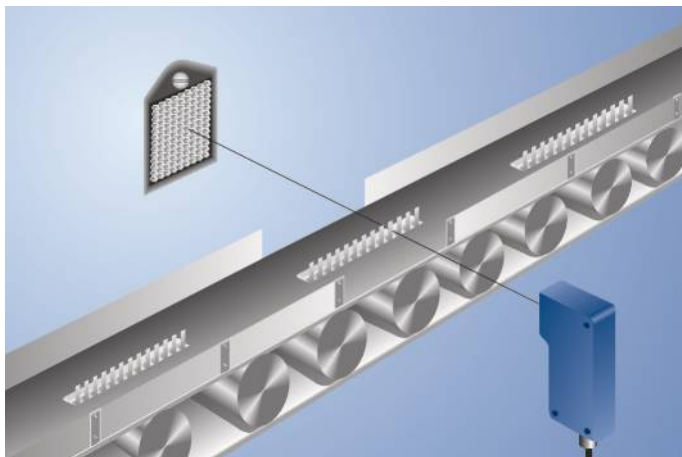

### Technical Data

Optical Data	
Range	9500 mm
Reference Reflector/Reflector Foil	RQ100BA
Min. Distance to Reflector	0 mm
Smallest Recognizable Part	> 250 $\mu\text{m}$
Switching Hysteresis	< 15 %
Light Source	Laser (red)
Wavelength	670 nm
Polarization Filter	yes
Service Life (T = +25 °C)	100000 h
Laser Class (EN 60825-1)	2
Max. Ambient Light	10000 Lux
Opening Angle	0,6 °
Light Spot Diameter	see Table 1
Single-Lens Optic	yes
Electrical Data	
Supply Voltage	10...30 V DC
Current Consumption (U <sub>b</sub> = 24 V)	< 30 mA
Switching Frequency	5 kHz
Response Time	100 $\mu\text{s}$
On-Delay	20 ms
Temperature Drift	< 10 %
Temperature Range	-25...60 °C
Switching Output Voltage Drop	< 2,5 V
PNP Switching Output/Switching Current	200 mA
Short Circuit Protection	yes
Reverse Polarity Protection	yes
Protection Class	III
FDA Accession Number	0820394-002
Mechanical Data	
Setting Method	Potentiometer
Housing Material	Plastic
Full Encapsulation	yes
Degree of Protection	IP67
Connection	M12 × 1; 4-pin
PNP NO	●
Connection Diagram No.	<b>111</b>
Control Panel No.	<b>N4   No2</b>
Suitable Connection Equipment No.	<b>2</b>
Suitable Mounting Technology No.	<b>350</b>

### Complementary Products

- Dust Extraction Tube STAUBTUBUS-03
- PNP-NPN Converter BG2V1P-N-2M
- Reflector, Reflector Foil
- Set Protective Housing ZSN-NN-02

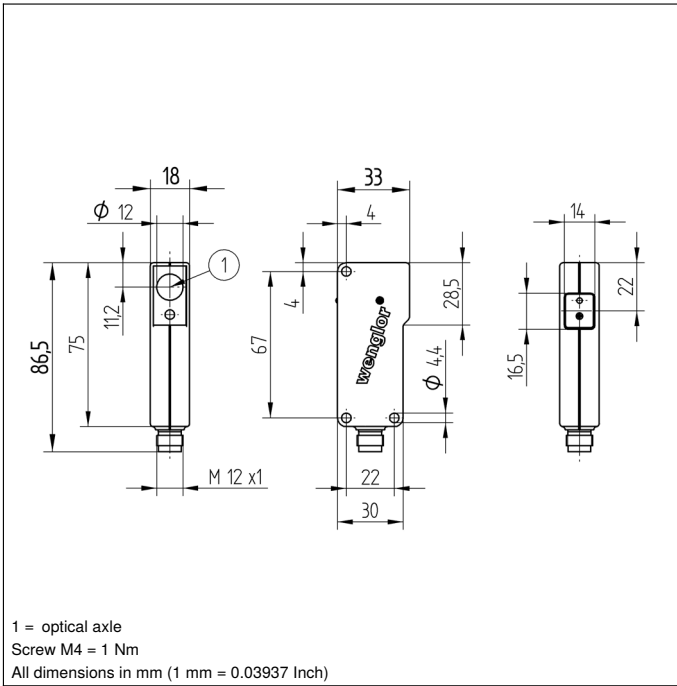
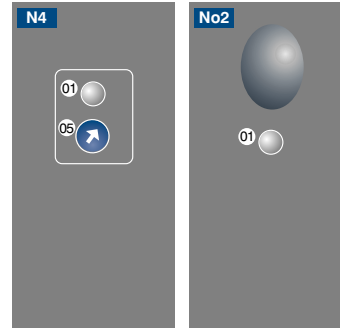
**Ctrl. Panel Optic**

01 = Switching Status Indicator  
 05 = Switching Distance Adjuster

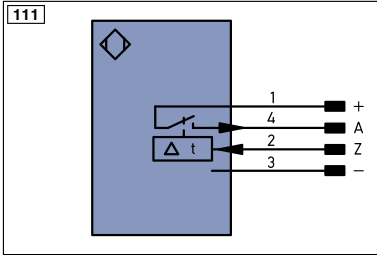

Legend		Legend		Legend	
+	Supply Voltage +	PT	Platinum measuring resistor	EN <sup>A/RS422</sup>	Encoder A/ $\bar{A}$ (TTL)
-	Supply Voltage 0 V	nc	not connected	EN <sup>B/RS422</sup>	Encoder B/ $\bar{B}$ (TTL)
~	Supply Voltage (AC Voltage)	U	Test Input	EN <sub>A</sub>	Encoder A
A	Switching Output (NO)	$\bar{U}$	Test Input inverted	EN <sub>B</sub>	Encoder B
$\bar{A}$	Switching Output (NC)	W	Trigger Input	A <sub>MIN</sub>	Digital output MIN
V	Contamination/Error Output (NO)	W-	Ground for the Trigger Input	A <sub>MAX</sub>	Digital output MAX
$\bar{V}$	Contamination/Error Output (NC)	O	Analog Output	A <sub>OK</sub>	Digital output OK
E	Input (analog or digital)	O-	Ground for the Analog Output	SY <sub>in</sub>	Synchronization In
T	Teach Input	BZ	Block Discharge	SY <sub>OUT</sub>	Synchronization OUT
Z	Time Delay (activation)	AWV	Valve Output	OLT	Brightness output
S	Shielding	a	Valve Control Output +	M	Maintenance
RxD	Interface Receive Path	b	Valve Control Output 0 V	rsv	reserved
TxD	Interface Send Path	SY	Synchronization	Wire Colors according to DIN IEC 757	
RDY	Ready	SY-	Ground for the Synchronization	BK	Black
GND	Ground	E+	Receiver-Line	BN	Brown
CL	Clock	S+	Emitter-Line	RD	Red
E/A	Output/Input programmable	$\pm$	Grounding	OG	Orange
	IO-Link	S <sub>n</sub> R	Switching Distance Reduction	YE	Yellow
PoE	Power over Ethernet	Rx+/-	Ethernet Receive Path	GN	Green
IN	Safety Input	Tx+/-	Ethernet Send Path	BU	Blue
OSSD	Safety Output	Bus	Interfaces-Bus A(+)/B(-)	VT	Violet
Signal	Signal Output	L <sub>a</sub>	Emitted Light disengageable	GY	Grey
Bl.-D +/-	Ethernet Gigabit bidirect. data line (A-D)	Mag	Magnet activation	WH	White
EN <sup>0/RS422</sup>	Encoder 0-pulse 0-0 (TTL)	RES	Input confirmation	PK	Pink
		EDM	Contactur Monitoring	GNVE	Green/Yellow

**Table 1**

Working Distance	0,2 m	3 m	6 m
Light Spot Diameter	3 mm	45 mm	90 mm

**Feasible reflector distance**

Reflector type, mounting distance

RQ100BA	0...9,5 m	RR25_M	0...3,5 m
RE18040BA	0...6 m	RR25KP	0...1,5 m
RQ84BA	0...7 m	RR21_M	0...1,4 m
RR84BA	0...9,5 m	ZRAE02B01	0...4 m
RE9538BA	0...2,5 m	ZRME01B01	0...1,3 m
RE6151BM	0...8,5 m	ZRME03B01	0...3,5 m
RR50_A	0...6,5 m	ZRMR02K01	0...1,5 m
RE6040BA	0...8,5 m	ZRMS02_01	0...1,5 m
RE8222BA	0...3,5 m	RF505	0...2,3 m
RR34_M	0...3,5 m	RF508	0...2 m
RE3220BM	0...3 m	RF258	0...1,8 m
RE6210BM	0...2,5 m	ZRDF_K01	0...6 m

