

# Retro-Reflex Sensor

## OLDK503A0002

Part Number



- Clever inclusive mounting technology
- Glossy objects can be detected
- Minimal installation space
- Simple installation
- Switching distance adjuster

A reflector must be used in combination with these sensors. They can be installed in all kinds of industrial environments thanks to ample functional reserve. Even reflective objects can be reliably recognized through the use of polarized light.

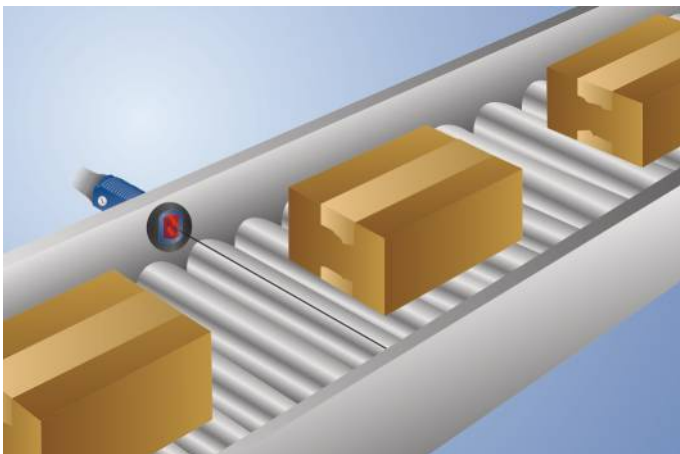

### Technical Data

Optical Data	
Range	5000 mm
Reference Reflector/Reflector Foil	RQ100BA
Switching Hysteresis	< 15 %
Light Source	Red Light
Polarization Filter	yes
Service Life (T = +25 °C)	100000 h
Max. Ambient Light	10000 Lux
Opening Angle	5 °
Light Spot Diameter	see Table 1
Two-Lens Optic	yes
Electrical Data	
Supply Voltage	10...30 V DC
Current Consumption (U <sub>b</sub> = 24 V)	< 30 mA
Switching Frequency	700 Hz
Response Time	714 μs
Temperature Drift	< 10 %
Temperature Range	-25...60 °C
Switching Output Voltage Drop	< 2,5 V
PNP Switching Output/Switching Current	200 mA
Residual Current Switching Output	< 50 μA
Short Circuit Protection	yes
Reverse Polarity Protection	yes
Overload Protection	yes
Protection Class	III
Mechanical Data	
Setting Method	Potentiometer
Housing Material	Plastic
Degree of Protection	IP67
Connection	M12 × 1; 4-pin
Scope of delivery	Mounting Console
PNP NO/NC antivalent	●
Connection Diagram No.	101
Control Panel No.	DK1
Suitable Connection Equipment No.	2
Suitable Mounting Technology No.	150

### Complementary Products

Dust Extraction Tube STAUBTUBUS-01
PNP-NPN Converter BG2V1P-N-2M
Reflector, Reflector Foil

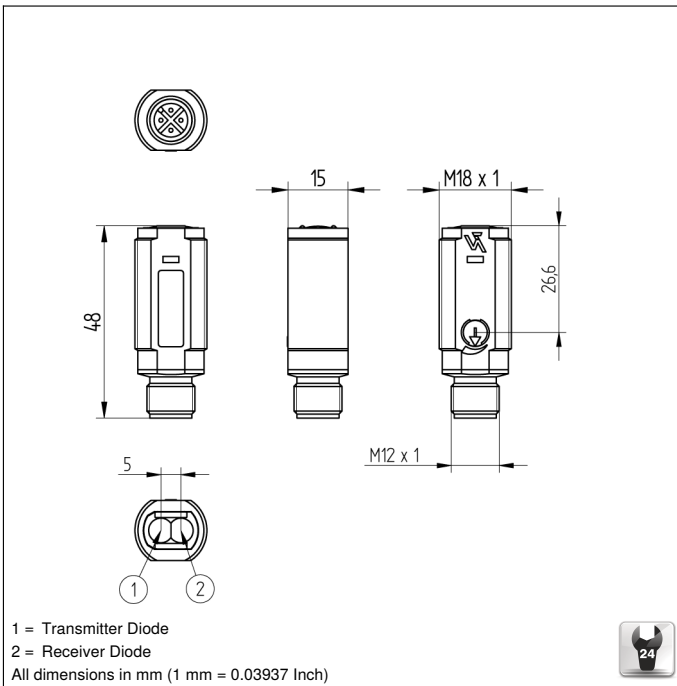

### Ctrl. Panel

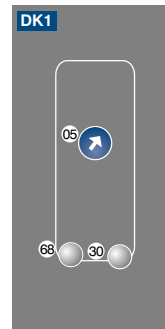

05 = Switching Distance Adjuster  
 30 = Switching Status/Contamination Warning  
 68 = Supply Voltage Indicator

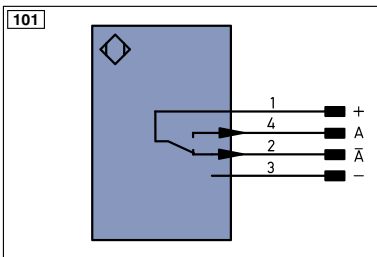

Legend			
+	Supply Voltage +	PT	Platinum measuring resistor
-	Supply Voltage 0 V	nc	not connected
~	Supply Voltage (AC Voltage)	U	Test Input
A	Switching Output (NO)	Ū	Test Input inverted
Ā	Switching Output (NC)	W	Trigger Input
V	Contamination/Error Output (NO)	W-	Ground for the Trigger Input
Ṽ	Contamination/Error Output (NC)	O	Analog Output
E	Input (analog or digital)	O-	Ground for the Analog Output
T	Teach Input	BZ	Block Discharge
Z	Time Delay (activation)	AWV	Valve Output
S	Shielding	a	Valve Control Output +
RxD	Interface Receive Path	b	Valve Control Output 0 V
TxD	Interface Send Path	SY	Synchronization
RDY	Ready	SY-	Ground for the Synchronization
GND	Ground	E+	Receiver-Line
CL	Clock	S+	Emitter-Line
E/A	Output/Input programmable	±	Grounding
	IO-Link	SnR	Switching Distance Reduction
PoE	Power over Ethernet	Rx+/-	Ethernet Receive Path
IN	Safety Input	Tx+/-	Ethernet Send Path
OSSD	Safety Output	Bus	Interfaces-Bus A(+)/B(-)
Signal	Signal Output	La	Emitted Light disengageable
Bl..D+/-	Ethernet Gigabit bidirect. data line (A-D)	Mag	Magnet activation
EN0..5422	Encoder 0-pulse 0-0 (TTL)	RES	Input confirmation
		EDM	Contactor Monitoring
		EN1..65422	Encoder A/Ā (TTL)
		EN2..65422	Encoder B/B̄ (TTL)
		ENa	Encoder A
		ENb	Encoder B
		AMIN	Digital output MIN
		AMAX	Digital output MAX
		AOK	Digital output OK
		SY in	Synchronization In
		SY OUT	Synchronization OUT
		OLT	Brightness output
		M	Maintenance
		rsv	reserved
		Wire Colors according to DIN IEC 757	
		BK	Black
		BN	Brown
		RD	Red
		OG	Orange
		YE	Yellow
		GN	Green
		BU	Blue
		VT	Violet
		GY	Grey
		WH	White
		PK	Pink
		GNVE	Green/Yellow

**Table 1**

Working Distance	0,2 m	0,5 m	5 m
Light Spot Diameter	17 mm	35 mm	330 mm

### Feasible reflector distance

Reflector type, mounting distance

RQ100BA	0,01...5 m	RR21_M	0,01...1,1 m
RE18040BA	0,01...4,5 m	ZRAE02B01	0,01...2,2 m
RQ84BA	0,01...4,5 m	ZRDS01R01	0,05...0,8 m
RR84BA	0,01...4,5 m	ZRME01B01	0,01...0,5 m
RE9538BA	0,01...2,2 m	ZRME03B01	0,01...2,5 m
RE6151BM	0,01...4,3 m	ZRMR02K01	0,01...0,7 m
RR50_A	0,01...3,5 m	ZRMS02_01	0,01...1 m
RE6040BA	0,01...4 m	RF505	0,05...1,5 m
RE8222BA	0,01...2,6 m	RF508	0,05...1,5 m
RR34_M	0,01...2,5 m	RF258	0,05...1,1 m
RE3220BM	0,01...1,5 m	ZRAF07K01	0,05...1,1 m
RE6210BM	0,01...1 m	ZRAF08K01	0,05...1,5 m
RR25_M	0,01...1,3 m	ZRDF03K01	0,04...3,4 m
RR25KP	0,04...0,8 m	ZRDF10K01	0,04...4,5 m

