

Female connector, field-attachable

V15L-G-BK



- Field-attachable
- Screw terminal connection
- Metal locking
- Knurled nut suitable for tool assembly

Female connector M12 straight L-coded 5-pin, for cable diameter 8 - 13 mm, field-attachable



Dimensions

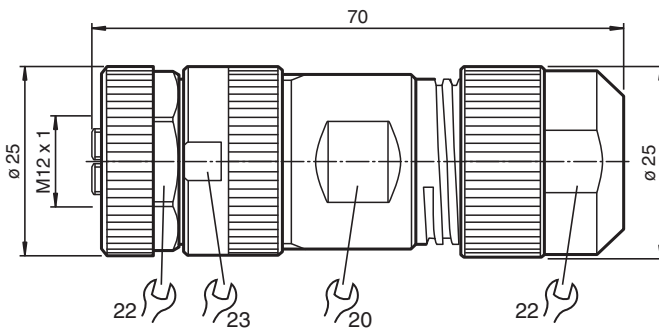

Technical Data

General specifications			
Connector 1			
Connection			socket
Construction type			M12
Style			straight
Locking			screw connection
Number of pins			5
Coding			L-coded
Electrical specifications			
Rated operating voltage	U_e		max. 48 V AC / 63 V DC
Rated operating current	I_e		1.5 mm ² , AWG 16 : 12 A 2.5 mm ² , AWG 14 : 16 A
Insulation resistance			min. 10000 M Ω
Conformity			
Degree of protection			EN 60529
Plug connection			connector M12 x 1 : IEC 61076-2-101
Ambient conditions			

Release date: 2023-08-18 Date of issue: 2023-08-18 Filename: 318791_eng.pdf

Refer to "General Notes Relating to Pepperl+Fuchs Product Information".

Pepperl+Fuchs Group
www.pepperl-fuchs.com

USA: +1 330 486 0001
fa-info@us.pepperl-fuchs.com

Germany: +49 621 776 1111
fa-info@de.pepperl-fuchs.com

Singapore: +65 6779 9091
fa-info@sg.pepperl-fuchs.com

PEPPERL+FUCHS

Technical Data

Ambient temperature	-40 ... 105 °C (-40 ... 221 °F)
Pollution degree	3
Mechanical specifications	
Plug connector	
Tightening torque	0.6 Nm
Tool installation	straight knurling , hexagon nut SW = 22 mm
Mating cycles	min. 100
Degree of protection	IP67
Connection	screw terminals for max. 1.5 mm ² / AWG 16 with wire end ferrule screw terminals for max. 2.5 mm ² / AWG 14 without wire end ferrule
Cable	
Sheath diameter	8 ... 13 mm
Mass	50.37 g
Material	
Plug connector	
Screw connection	CuZn, nickel-plated
Body	PA, black
Contact surface	Au
Flammability	V-0

Connection Assignment



Accessories

	CBL-PUR-U-GY-05x150-100M	Cable, PUR/PP, 5-core grey, UL approved, drag chain suitable, torsion resistant, oil resistant
---	---------------------------------	--