

Lithium ion battery 1200 mAh

OHV210-BAT



- Lithium ion battery
- Capacity 1200 mAh
- LED indicator for supply status

Lithium ion battery 1200 mAh

Dimensions

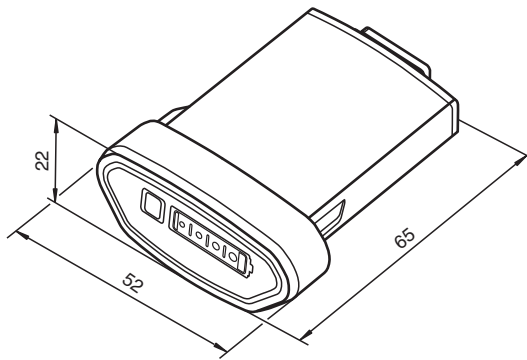

Technical Data

Electrical specifications	
Nominal capacity	1200 mAh , capacity can varies with usage conditions
Mechanical specifications	
Mass	approx. 50 g
Dimensions	52 mm x 22 mm x 65 mm (W x H x D)

Release date: 2022-04-25 Date of issue: 2022-04-25 Filename: 70145386_eng.pdf

Refer to "General Notes Relating to Pepperl+Fuchs Product Information".

Pepperl+Fuchs Group
www.pepperl-fuchs.com

USA: +1 330 486 0001
fa-info@us.pepperl-fuchs.com

Germany: +49 621 776 1111
fa-info@de.pepperl-fuchs.com

Singapore: +65 6779 9091
fa-info@sg.pepperl-fuchs.com

 **PEPPERL+FUCHS**