

# Thru-beam sensor

## ML30-P/25/102/115

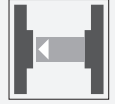

- Single-beam monitoring with extremely narrow sensor
- Integrated circuit
- Test
- Simple installation - Plug & Play
- Ideal for installation in door profiles or frames
- Compact housing version with 2 mounting options

Single-beam miniature sensor, ideal for installing in frames or door profiles



### Function

The narrow miniature thru-beam sensors are a small and cost-effective solution, fitting in virtually any door frame. The ML29 and ML30 series offer fast, reliable detection at a distance of up to 8.5 m. The sensors are easy to mount on the profile, either using adhesive strips or a screw. A large opening angle ensures problem-free alignment. Several sensors can be mounted in a cross formation to offer multi-beam protection.

### Application

- Person detection for automatic doors and gates
- Closing edge protection on sliding and revolving doors
- Threshold monitoring for elevator doors
- Step monitoring for doors on public transport vehicles
- Trigger function for restarting escalators

## Dimensions

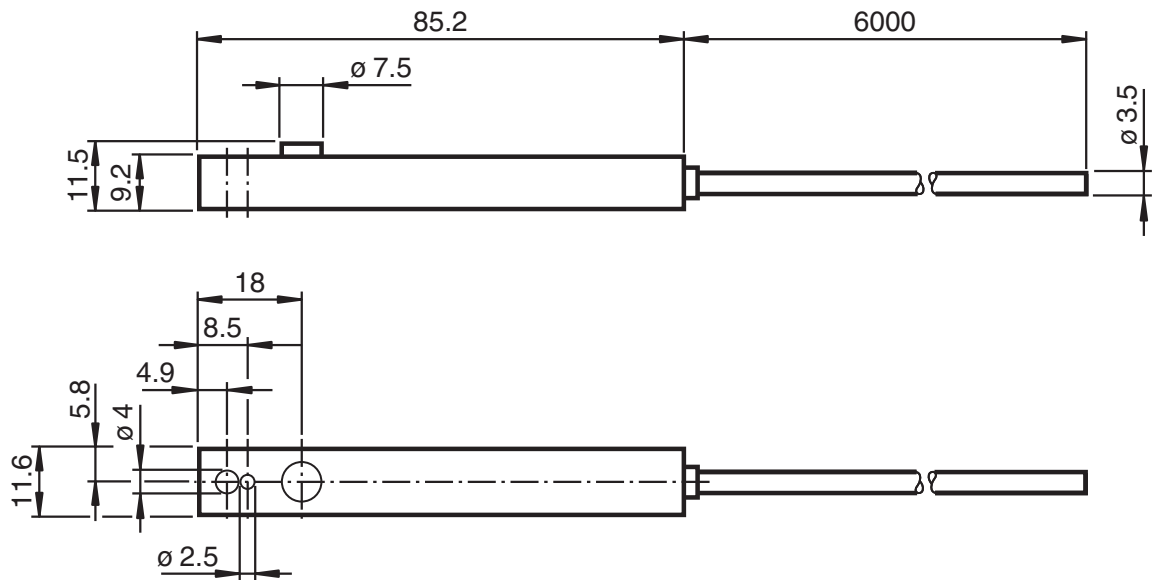

## Technical Data

<b>System components</b>	
Emitter	ML30-T/115
Receiver	ML30-R/25/102/115
<b>General specifications</b>	
Effective detection range	0 ... 6 m
Threshold detection range	8.5 m
Light source	IRED
Light type	modulated infrared light
Opening angle	+/- 8 °
Optical face	lateral
Ambient light limit	40000 Lux
<b>Indicators/operating means</b>	
Function indicator	LED red in receiver : lights up when receiving the light beam
<b>Electrical specifications</b>	
Operating voltage	$U_B$ 10 ... 32 V DC
No-load supply current	$I_0$ Emitter: $\leq 25$ mA Receiver: $\leq 10$ mA
<b>Input</b>	
Test input	Test: Transmitter switches off at $+U_B \leq 5$ V DC
<b>Output</b>	
Switching type	light-on
Signal output	1 NPN output, short-circuit protected, reverse polarity protected, open collector

Release date: 2023-05-04 Date of issue: 2023-05-04 Filename: 207415\_eng.pdf

Refer to "General Notes Relating to Pepperl+Fuchs Product Information".

Pepperl+Fuchs Group  
www.pepperl-fuchs.com

USA: +1 330 486 0001  
fa-info@us.pepperl-fuchs.com

Germany: +49 621 776 1111  
fa-info@de.pepperl-fuchs.com

Singapore: +65 6779 9091  
fa-info@sg.pepperl-fuchs.com

 PEPPERL+FUCHS

**Technical Data**

Switching voltage		max. 30 V DC
Switching current		max. 0.1 A
Switching frequency	f	100 Hz
Response time		5 ms
<b>Conformity</b>		
Product standard		EN 60947-5-2
<b>Compliance with standards and directives</b>		
Standard conformity		
Standards		EN 61000-6-2, EN 61000-6-3
<b>Approvals and certificates</b>		
CCC approval		CCC approval / marking not required for products rated ≤36 V
<b>Ambient conditions</b>		
Ambient temperature		-20 ... 60 °C (-4 ... 140 °F)
Storage temperature		-20 ... 75 °C (-4 ... 167 °F)
<b>Mechanical specifications</b>		
Degree of protection		IP65
Connection		6 m fixed cable
Material		
Housing		PMMA , black
Optical face		Plastic pane
Mass		per device 120 g

**Connection Assignment**

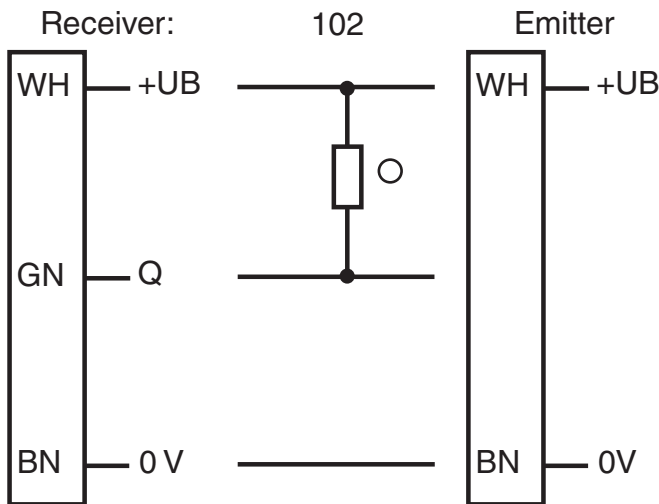

○ = Light on  
● = Dark on

**Assembly**

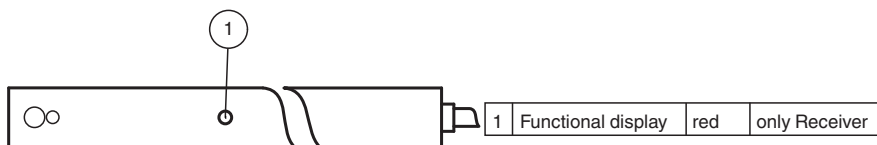

Release date: 2023-05-04 Date of issue: 2023-05-04 Filename: 207415\_eng.pdf

Refer to "General Notes Relating to Pepperl+Fuchs Product Information".

## Characteristic Curve

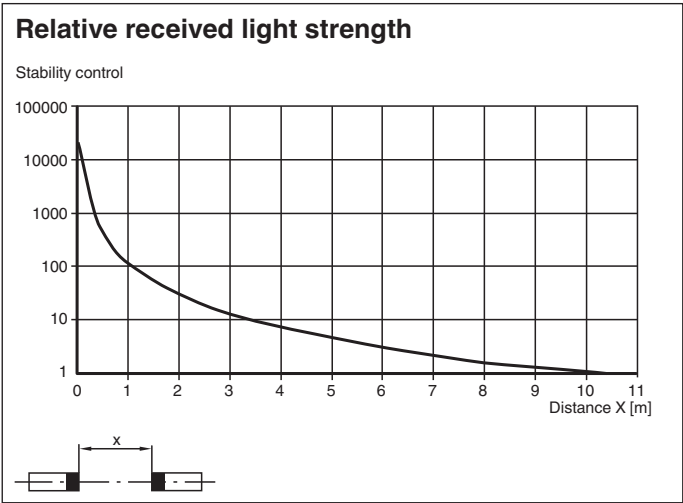
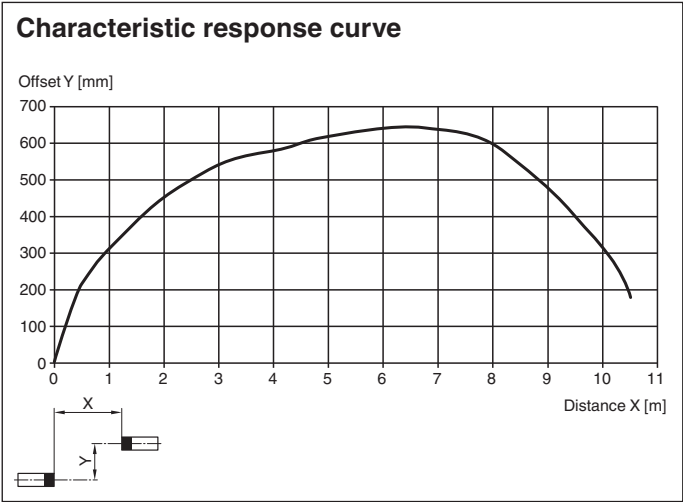

## Application

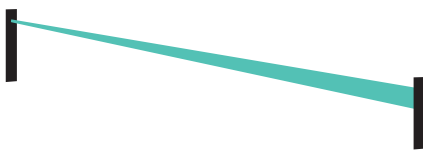

## Function Principle

The thru-beam sensor requires a pair of devices for operation, comprising a light transmitter and a light receiver. The emitter and receiver must be arranged in optical alignment with each other. The infrared light from the emitter is detected by the receiver and evaluated.

Release date: 2023-05-04 Date of issue: 2023-05-04 Filename: 207415\_eng.pdf

**Accessories**

	<b>ML29 Front Plate</b>	Front plate for thru-beam sensors in series ML29
---	-------------------------	--

Release date: 2023-05-04 Date of issue: 2023-05-04 Filename: 207415\_eng.pdf

Refer to "General Notes Relating to Pepperl+Fuchs Product Information".

Pepperl+Fuchs Group  
www.pepperl-fuchs.com

USA: +1 330 486 0001  
fa-info@us.pepperl-fuchs.com

Germany: +49 621 776 1111  
fa-info@de.pepperl-fuchs.com

Singapore: +65 6779 9091  
fa-info@sg.pepperl-fuchs.com

**Additional Information**

**Static detection:**

The thru-beam sensor detects persons and objects independently of movement and surface structure for as long as the object breaks the detection beam.

		Electronic output
Light detection /25	Person in the beam	Inactive
	No person in the beam	Active

**Optics:**

The relatively wide opening angles enable the light beam switches to be installed quickly, without alignment problems. Even if there is a light distortion of the installation profiles the function is retained.

**Testing:**

Testing is used to check the function of the thru-beam sensor.

With supply voltage  $+U_B < 5\text{ V}$  the emitter device is switched off. This simulates a light beam interruption. By means of this, the function of the light barrier can be tested easily without using a separate test input.

**Installation:**

Thanks to its small dimensions, the light beam can be fitted in a U-profile or behind a face panel. The hole diameter for both the emitter and the receiver is 4 mm.

Even fixing by means of the adhesive tape contained in the delivery package can be considered.

**Installation of twin-beam arrangement:**

A twin-beam version requires 2 emitters and receivers. Care should be taken that the beam separation is not less than 20 cm. The transmitters and receivers must be arranged in the form of a cross.

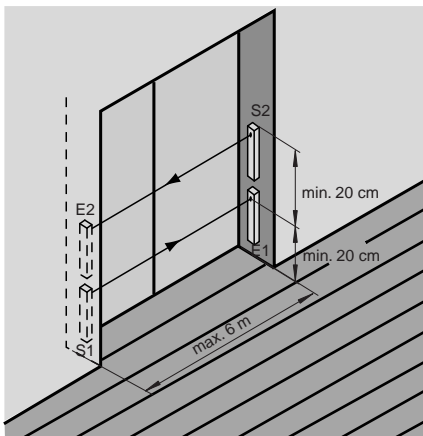

Release date: 2023-05-04 Date of issue: 2023-05-04 Filename: 207415\_eng.pdf