



Photoelectric slot sensor

GL40-IR/32/40a/98a



- Optimized for the detection of small parts
- High switching frequency
- Multiple device installation possible, no mutual interference (no cross-talk)
- Sensitivity adjuster and light-on/dark-on changeover switch as standard features of this series
- Infrared light
- Degree of protection IP67
- cULus approval
- Sturdy aluminum housing

Photoelectric slot sensor, aluminum housing, 40 mm slot width, infrared light, light/dark on, sensitivity adjuster, DC version, PNP output, 3 pin M8 plug



Function

Photoelectric slot sensors offer vast installation benefits thanks to their housing design. When it comes to operation, these new generation devices boast features such as high resolution, high repeatability, automatic signal threshold adjustment, ambient light resistance, and detection of and/or light transmission through transparent objects. Cross-talk protection enables parallel installation of devices despite extremely high switching frequency. These characteristics guarantee reliable detection of small parts, from 0.3 mm, across the entire detection range, even in very fast moving applications.

Dimensions

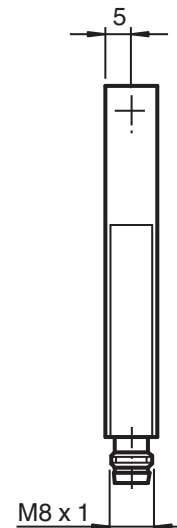
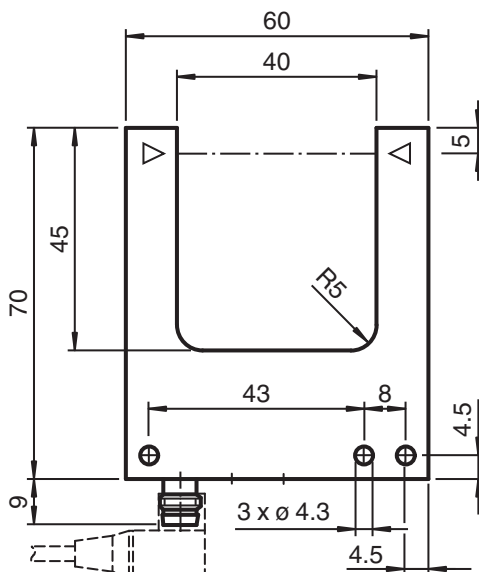
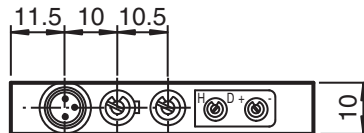

Technical Data

General specifications		
Light source		IRE D
Light type		modulated infrared light
Tests		EN 60947-5-2
Target size		0.3 mm
Slot width		40 mm
Slot depth		45 mm
Ambient light limit		100000 Lux
Indicators/operating means		
Function indicator		LED red in connector
Control elements		Sensitivity adjuster, light/dark switch
Electrical specifications		
Operating voltage	U_B	10 ... 30 V DC, class 2
Ripple		10 %
No-load supply current	I_0	≤ 15 mA
Output		
Switching type		light/dark on
Signal output		1 PNP, short-circuit protected, open collector
Switching voltage		max. 30 V DC
Switching current		max. 100 mA
Repeat accuracy		0.05 mm
Switching frequency	f	2 kHz
Response time		≤ 250 μs
Conformity		
Product standard		EN 60947-5-2
Approvals and certificates		
CE conformity		CE
UL approval		cULus
CCC approval		CCC approval / marking not required for products rated ≤36 V
Ambient conditions		
Ambient temperature		-20 ... 60 °C (-4 ... 140 °F)
Storage temperature		-20 ... 75 °C (-4 ... 167 °F)
Mechanical specifications		
Degree of protection		IP67
Connection		M8 connector, 3-pin
Material		
Housing		black anodized aluminum
Optical face		glass
Mass		45 g

Release date: 2023-05-09 Date of issue: 2023-05-09 Filename: 215057_eng.pdf

Refer to "General Notes Relating to Pepperl+Fuchs Product Information".

Pepperl+Fuchs Group
www.pepperl-fuchs.com

USA: +1 330 486 0001
fa-info@us.pepperl-fuchs.com

Germany: +49 621 776 1111
fa-info@de.pepperl-fuchs.com

Singapore: +65 6779 9091
fa-info@sg.pepperl-fuchs.com

 PEPPERL+FUCHS

Connection Assignment

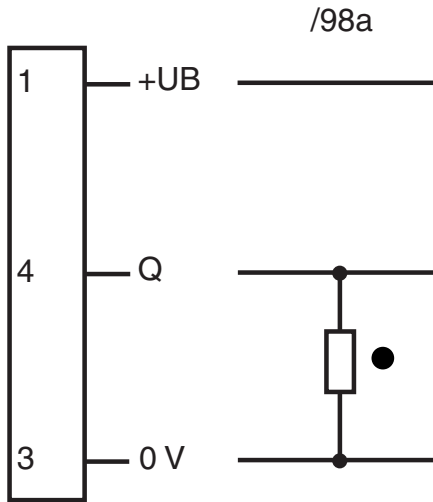

○ = Light on
● = Dark on

Connection Assignment

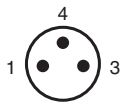

Wire colors in accordance with EN 60947-5-2

- 1 | BN (brown)
- 3 | BU (blue)
- 4 | BK (black)

Assembly

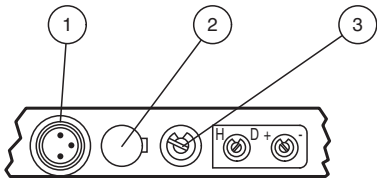

1	Functional display	red
2	Light-/dark switch	
3	Sensitivity adjuster	

Release date: 2023-05-09 Date of issue: 2023-05-09 Filename: 215057_eng.pdf

Refer to "General Notes Relating to Pepperl+Fuchs Product Information".

Application

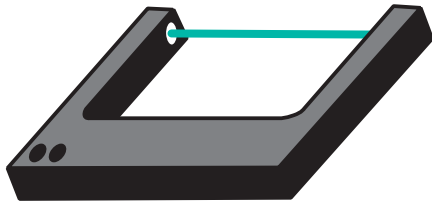

Function Principle

Photoelectric slot sensors are photoelectric sensors that operate according to the thru-beam sensor principle. The transmitter sends signals directly to the receiver. If an object breaks the light beam, the switching element function is triggered. The special U-shaped design means the transmitter and receiver can be accommodated in one housing, which ensures high resistance to vibrations. In contrast to standard thru-beam sensors, photoelectric slot sensors have the added advantage of not requiring complex electrical installation, as only one device needs to be connected. Also, adjustment of the optical axes is not necessary.

Accessories

	V3-WM-2M-PUR	Female cordset single-ended M8 angled A-coded, 3-pin, PUR cable grey
---	---------------------	--

Application

- Small part detection, from object size 0.3 mm
- Can also be used for systems with strong vibrations
- Detection of small needles in transparent hollow needles
- Counting of small parts on conveyors
- Feed and correct separation verification
- Web edge control
- Elevator car position in elevators