

Dimensions

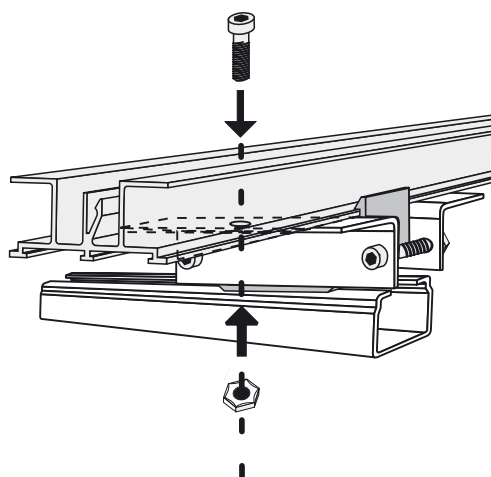

Technical data

Mechanical specifications

Material	Metal sheet (steel), zinc-plated
Mass	50 g

Notes

To prevent the aluminium profile rails slipping in the rail holders when installed horizontally, a locking bracket is necessary. The locking bracket WCS2-LB1 is fitted around a rail holder in the middle of the runway. During installation, bracket and aluminium profile are joined with the screw supplied. To do this, the aluminium profile must be drilled through at one point (drill 7 mm).

Model number

WCS2-LB1

WCS2 locking bracket

Features

- Easy setting of fixed points

Matching system components

WCS2-PS1-2,5M

WCS2 profile rail

WCS2-PS1-8FT

WCS2 profile rail

WCS2-PS1

WCS2 profile rail