



# Ultrasonic sensor

## UB1000-18GM75A-I-V15

- Analog output 4 mA ... 20 mA
- Measuring window adjustable
- Selectable sound lobe width
- Program input
- Synchronization options
- Deactivation option
- Temperature compensation
- Very small unusable area

Single head system



### Dimensions

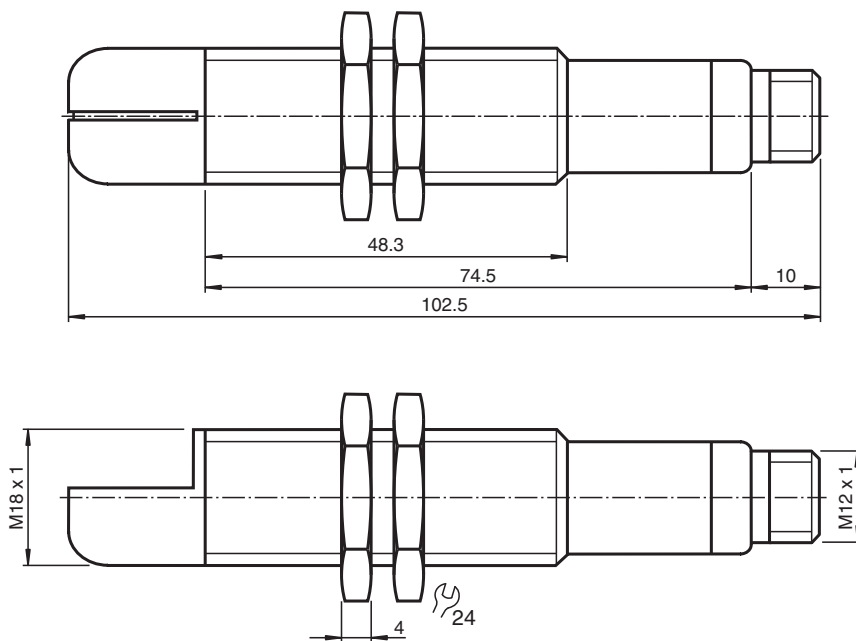

### Technical Data

#### General specifications

Sensing range	70 ... 1000 mm
Adjustment range	90 ... 1000 mm
Dead band	0 ... 70 mm
Standard target plate	100 mm x 100 mm
Transducer frequency	approx. 255 kHz
Response delay	approx. 125 ms

#### Indicators/operating means

LED yellow	solid yellow: object in the evaluation range yellow, flashing: program function, object detected
------------	---

Release date: 2023-02-15 Date of issue: 2023-02-15 Filename: 204541\_eng.pdf

Refer to "General Notes Relating to Pepperl+Fuchs Product Information".

Pepperl+Fuchs Group  
www.pepperl-fuchs.com

USA: +1 330 486 0001  
fa-info@us.pepperl-fuchs.com

Germany: +49 621 776 1111  
fa-info@de.pepperl-fuchs.com

Singapore: +65 6779 9091  
fa-info@sg.pepperl-fuchs.com

**PF** PEPPERL+FUCHS

**Technical Data**

LED red	solid red: Error red, flashing: program function, object not detected	
<b>Electrical specifications</b>		
Operating voltage	$U_B$	10 ... 30 V DC , ripple 10 % <sub>SS</sub>
No-load supply current	$I_0$	≤ 45 mA
<b>Input/Output</b>		
Synchronization		bi-directional 0 level: $-U_B \dots +1$ V 1 level: $+4$ V $\dots +U_B$ input impedance: > 12 KOhm synchronization pulse: ≥ 100 μs, synchronization interpulse period: ≥ 2 ms
Synchronization frequency		
Common mode operation		max. 40 Hz
Multiplex operation		≤ 40 Hz / n, n = number of sensors, n ≤ 5
<b>Input</b>		
Input type		1 program input lower evaluation limit A1: $-U_B \dots +1$ V, upper evaluation limit A2: $+4$ V $\dots +U_B$ input impedance: > 4.7 kΩ, pulse duration: ≥ 1 s
<b>Output</b>		
Output type		1 analog output 4 ... 20 mA
Resolution		0.35 mm
Deviation of the characteristic curve		± 1 % of full-scale value
Repeat accuracy		± 0.1 % of full-scale value
Load impedance		0 ... 300 Ohm
Temperature influence		± 1.5 % of full-scale value
<b>Compliance with standards and directives</b>		
Standard conformity		
Standards		EN IEC 60947-5-2:2020 IEC 60947-5-2:2019 EN 60947-5-7:2003 IEC 60947-5-7:2003
<b>Approvals and certificates</b>		
UL approval		cULus Listed, Class 2 Power Source
CCC approval		CCC approval / marking not required for products rated ≤36 V
<b>Ambient conditions</b>		
Ambient temperature		-25 ... 70 °C (-13 ... 158 °F)
Storage temperature		-40 ... 85 °C (-40 ... 185 °F)
<b>Mechanical specifications</b>		
Connection type		Connector plug M12 x 1 , 5-pin
Housing diameter		18 mm
Degree of protection		IP67
Material		
Housing		brass, nickel-plated
Transducer		epoxy resin/hollow glass sphere mixture; polyurethane foam
Mass		60 g

**Connection**

Standard symbol/Connections:  
(version I)

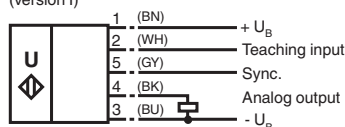

Core colours in accordance with EN 60947-5-2.

Release date: 2023-02-15 Date of issue: 2023-02-15 Filename: 204541\_eng.pdf

## Connection Assignment

### Connector V15



## Characteristic Curve

### Characteristic response curve

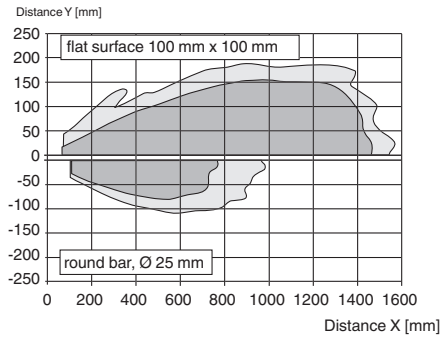

### Programming the analog output mode

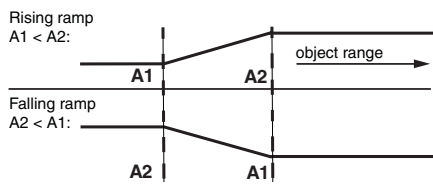



## Accessories

	<b>UB-PROG2</b>	Programming unit
	<b>OMH-04</b>	Mounting aid for round steel $\varnothing$ 12 mm or sheet 1.5 mm ... 3 mm
	<b>BF 18</b>	Mounting flange, 18 mm
	<b>BF 18-F</b>	Plastic mounting adapter, 18 mm
	<b>BF 5-30</b>	Universal mounting bracket for cylindrical sensors with a diameter of 5 ... 30 mm
	<b>UVW90-K18</b>	Ultrasonic -deflector

Release date: 2023-02-15 Date of issue: 2023-02-15 Filename: 204541\_eng.pdf

Refer to "General Notes Relating to Pepperl+Fuchs Product Information".

**Accessories**

	<p><b>M18K-VE</b></p>	<p>Plastic nuts with centering ring for the vibration-free mounting of cylindrical sensors</p>
	<p><b>V15-G-2M-PVC</b></p>	<p>Female cordset single-ended M12 straight A-coded, 5-pin, PVC cable grey</p>
	<p><b>V15-W-2M-PVC</b></p>	<p>Female cordset single-ended M12 angled A-coded, 5-pin, PVC cable grey</p>

Release date: 2023-02-15 Date of issue: 2023-02-15 Filename: 204541\_eng.pdf

Refer to "General Notes Relating to Pepperl+Fuchs Product Information".

Pepperl+Fuchs Group  
www.pepperl-fuchs.com

USA: +1 330 486 0001  
fa-info@us.pepperl-fuchs.com

Germany: +49 621 776 1111  
fa-info@de.pepperl-fuchs.com

Singapore: +65 6779 9091  
fa-info@sg.pepperl-fuchs.com

**Additional Information**

**Synchronisation**

The sensor features a synchronisation input for the suppression of mutual interference. If this input is not used, the sensor will operate using an internally generated clock rate. The synchronisation of multiple sensors can be realised as follows:

**External synchronisation**

The sensor can be synchronised by the external application of a square wave voltage. A synchronisation pulse at the synchronisation input starts a measuring cycle. The pulse must have a duration greater than 100 µs. The measuring cycle starts with the falling edge of a synchronisation pulse. A low level > 1 s or an open synchronisation input will result in the normal operation of the sensor. A high level at the synchronisation input disables the sensor. Two operating modes are available:

1. Multiple sensors can be controlled by the same synchronisation signal. The sensors are synchronised.
2. The synchronisation pulses are sent cyclically to individual sensors. The sensors operate in multiplex mode.

**Internal synchronisation**

The synchronisation connections of up to 5 sensors capable of internal synchronisation are connected to one another. When power is applied, these sensors will operate in multiplex mode.

The response delay increases according to the number of sensors to be synchronised. Synchronisation cannot be performed during TEACH-IN and vice versa. The sensors must be operated in an unsynchronised manner to teach the evaluation limits.

**Note:**

If the option for synchronisation is not used, the synchronisation input has to be connected to ground (0V) or the sensor has to be operated via a V1 cable connector (4-pin).

**Adjusting the evaluation limits**

The ultrasonic sensor features an analogue output with two teachable evaluation limits. These are set by applying the supply voltage -U<sub>B</sub> or +U<sub>B</sub> to the TEACH-IN input. The supply voltage must be applied to the TEACH-IN input for at least 1 s. LEDs indicate whether the sensor has recognised the target during the TEACH-IN procedure. The lower evaluation limit A1 is taught with -U<sub>B</sub>, A2 with +U<sub>B</sub>.

Two different output functions can be set:

1. Analogue value increases with rising distance to object (rising ramp)
2. Analogue value falls with rising distance to object (falling ramp)



Evaluation limits may only be specified within the first 5 minutes after Power on. To modify the evaluation limits later, the user may specify the desired values only after a new Power On.

**TEACH-IN rising ramp (A2 > A1)**

- Position object at lower evaluation limit
- TEACH-IN lower limit A1 with - U<sub>B</sub>
- Position object at upper evaluation limit
- TEACH-IN upper limit A2 with + U<sub>B</sub>

**TEACH-IN falling ramp (A1 > A2):**

- Position object at lower evaluation limit
- TEACH-IN lower limit A2 with + U<sub>B</sub>
- Position object at upper evaluation limit
- TEACH-IN upper limit A1 with - U<sub>B</sub>

**Default setting**

A1: unusable area  
 A2: nominal sensing range  
 Mode of operation: rising ramp

**LED Displays**

Displays in dependence on operating mode	Red LED	Yellow LED
<b>TEACH-IN evaluation limit</b>		
Object detected	off	flashes
No object detected	flashes	off
Object uncertain (TEACH-IN invalid)	on	off
Normal mode (evaluation range)	off	on
Fault	on	previous state

**Adjusting the sound cone characteristics:**

The ultrasonic sensor enables two different shapes of the sound cone, a wide angle sound cone and a small angle sound cone.

**1. Small angle sound cone**

Release date: 2023-02-15 Date of issue: 2023-02-15 Filename: 204541\_eng.pdf

- switch off the power supply
- connect the Teach-In input wire to -U<sub>B</sub>
- switch on the power supply
- the red LED flashes once with a pause before the next.
- yellow LED: permanently on: indicates the presence of an object or disturbing object within the sensing range
- disconnect the Teach-In input wire from -U<sub>B</sub> and the changing is saved



**2. Wide angle sound cone**

- switch off the power supply
- connect the Teach-In input wire with +U<sub>B</sub>
- switch on the power supply
- the red LED double-flashes with a long pause before the next.
- yellow LED: permanently on: indicates an object or disturbing object within the sensing range
- disconnect the Teach-In input wire from +U<sub>B</sub> and the changing is saved

