

Y-Splitter

V15S-Y-V15/V15



- Easy merging of two signals at a single M12 slot
- Degree of protection IP67
- Free of paint wetting interfering substances
- UL Recognized Component
- Knurled nut suitable for tool assembly
- Immunity to vibration, with mechanical latching
- Meets the VASS6 standard

Y-Splitter M12 plug to 2x M12 socket 5-pin A-coded



Dimensions

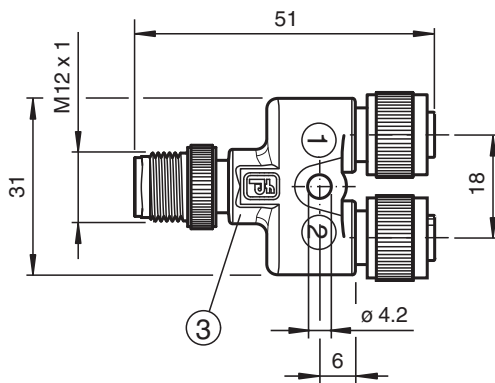

Technical Data

General specifications

Connector 1	
Connection	socket
Construction type	M12
Style	straight
Locking	screw connection
Number of pins	5
Coding	A-coded
Connector 2	
Connection	socket
Construction type	M12
Style	straight
Locking	screw connection
Number of pins	5
Coding	A-coded
Connector 3	
Connection	plug

Release date: 2023-06-30 Date of issue: 2023-06-30 Filename: 70109844_eng.pdf

Refer to "General Notes Relating to Pepperl+Fuchs Product Information".

Pepperl+Fuchs Group
www.pepperl-fuchs.com

USA: +1 330 486 0001
fa-info@us.pepperl-fuchs.com

Germany: +49 621 776 1111
fa-info@de.pepperl-fuchs.com

Singapore: +65 6779 9091
fa-info@sg.pepperl-fuchs.com

PEPPERL+FUCHS

Technical Data

Construction type		M12
Style		straight
Locking		screw connection
Number of pins		5
Coding		A-coded
Electrical specifications		
Operating voltage	U _B	max. 48 V AC / 60 V DC
Operating current	I _B	4 A
Conformity		
Degree of protection		EN 60529
Plug connection		connector M12 x 1 : IEC 61076-2-101
Flammability		UL 94
Approvals and certificates		
UL approval		UL 2238, 3rd Edition, CSA C22.2 No. 182.3-16.; CYJV/7
UL File Number		E231213
Ambient conditions		
Ambient temperature		-40 ... 90 °C (-40 ... 194 °F)
Pollution degree		3
Mechanical specifications		
Plug connector		
Tightening torque		0.6 Nm
Loosening protection		available
Tool installation		straight knurling
Mating cycles		min. 100
Degree of protection		IP67
Mounting		Mounting hole for M4 screw
Material		
Plug connector		
Screw connection		Zinc diecast, nickel-plated
Body		TPU
Contact surface		Au
Flammability		V-2

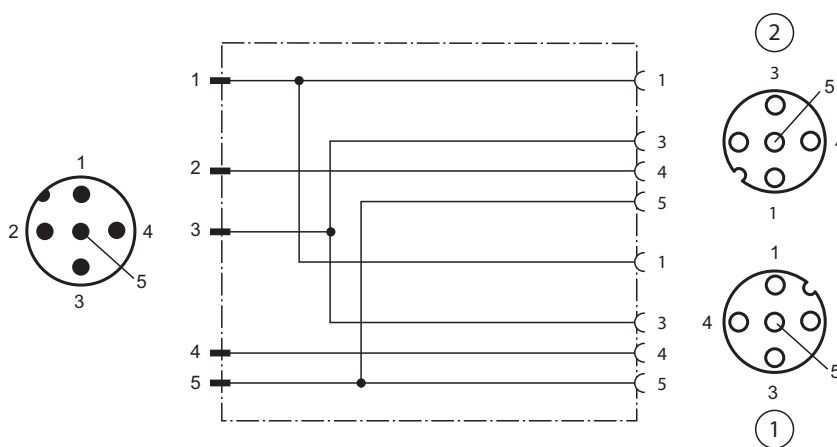

Connection Assignment



Release date: 2023-06-30 Date of issue: 2023-06-30 Filename: 70109844_eng.pdf

Refer to "General Notes Relating to Pepperl+Fuchs Product Information".

Accessories

	MH V1-SCREWDRIVER	Torque screwdriver (0.6 Nm)
	MH V1-BIT M12	plug-in cap M12