



Vibration Limit Switch

LVL-A7-BG1A-E5V1-CG-EMS

- Limit switch for liquids
- Process connection G1/2
- Suitable for process temperatures up to 150 °C (302 °F)
- Rugged stainless steel housing
- Onsite function check possible thanks to LED indication
- External function test with test magnet



Function

The Vibracon LVL-A7 is a limit switch for liquids and is used in tanks, vessels and pipes. The device is used for overflow prevention or pump protection in cleaning and filter systems as well as in cooling and lubrication vessels, for instance. The device is suitable for applications in which float switches or conductive, capacitance and optical sensors have been used up to now. The device also works in areas where these measuring principles are not suitable due to conductivity, buildup, turbulence, flow conditions or air bubbles. The device can be used for process temperatures up to 150 °C (302 °F). The device is not suitable for use in hazardous areas. For hygienic areas we recommend the use of Vibracon LVL A7H.

Connection



Dimensions

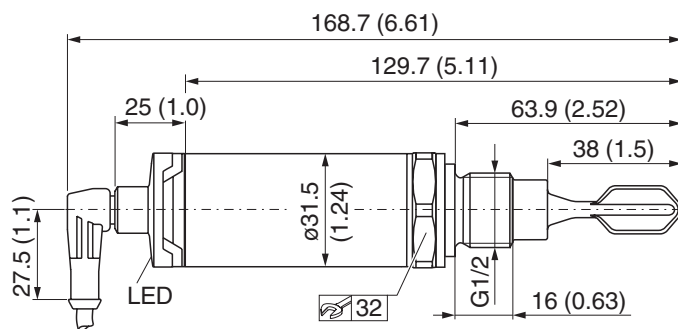

Release date: 2023-12-18 Date of issue: 2023-12-18 Filename: 275573-100029_eng.pdf

Refer to "General Notes Relating to Pepperl+Fuchs Product Information".

Pepperl+Fuchs Group
www.pepperl-fuchs.com

USA: +1 330 486 0002
pa-info@us.pepperl-fuchs.com

Germany: +49 621 776 2222
pa-info@de.pepperl-fuchs.com

Singapore: +65 6779 9091
pa-info@sg.pepperl-fuchs.com

PEPPERL+FUCHS

Technical Data

General specifications	
Measuring method	The tuning fork is brought to its resonance frequency by means of a piezoelectric drive. If the tuning fork is covered by liquid, this frequency changes. The electronics monitor the resonance frequency and indicate whether the tuning fork is freely vibrating or is covered by liquid.
Construction type	compact device
Operating mode	<p>MAX = maximum safety: The device keeps the electronic switch closed as long as the liquid level is below the fork. example application: overflow protection</p> <p>MIN = minimum safety: The device keeps the electronic switch closed as long as the fork is immersed in liquid. example application: dry running protection of pumps The electronic switch opens if the limit is reached, if a fault occurs or in the event of a power fails (quiescent current principle)</p>
Series	LVL-A*
Supply	
Connection	This device may be used with any sequential circuit, as long as the circuit can support the electrical circuit values of the switching elements.
Rated voltage	U_r 10 ... 35 V DC
Fusing	external 500 mA slow
Current consumption	< 15 mA
Power consumption	975 mW
Residual ripple	5 V _{ss} at 0 ... 400 Hz
Input	
Measured variable	density
Measurement range	min. 0.7 g/cm ³
Output	
Output type	switching output
Switching current	max. 250 mA
Directive conformity	
Electromagnetic compatibility	
Directive 2014/30/EU	EN 61326-1:2006 , EN 61326-2-3:2006
Directive 2004/108/EC	EN 61326-1:2006 , EN 61326-2-3:2006
Conformity	
Electromagnetic compatibility	NE 21
Degree of protection	IEC 60529
Shock resistance	EN 60068-2-27
Vibration resistance	EN 60068-2-64
Climate class	DIN EN 60068-2-38/IEC 68-2-38
Measurement accuracy	
Reference operating conditions	<ul style="list-style-type: none"> - ambient temperature: 25 °C (+77 °F) - process pressure: 1 bar (14.5 psi) - fluid: water (density: approx. 1 g/cm³, viscosity: 1 mm²/s) - medium temperature: 25 °C (+77 °F) - density setting: > 0.7 g/cm³ - switching time delay: standard (0,5 s, 1 s)
Measured value resolution	< 0.5 mm
Measuring frequency	approx. 1100 Hz in air
Switching point	13 mm ± 1 mm
Non-repeatability	± 1 mm acc. to DIN 61298-2
Hysteresis	max. 3 mm
Influence of ambient temperature	negligible
Influence of medium temperature	-25 µm/°C
Influence of medium pressure	-20 µm/bar
Switching time	<ul style="list-style-type: none"> - 0.5 s when tuning fork is covered - 1.0 s when tuning fork is uncovered
Switch-on delay	max. 3 s
Operating conditions	
Installation conditions	

Release date: 2023-12-18 Date of issue: 2023-12-18 Filename: 275573-100029_eng.pdf

Refer to "General Notes Relating to Pepperl+Fuchs Product Information".

 Pepperl+Fuchs Group
 www.pepperl-fuchs.com

 USA: +1 330 486 0002
 pa-info@us.pepperl-fuchs.com

 Germany: +49 621 776 2222
 pa-info@de.pepperl-fuchs.com

 Singapore: +65 6779 9091
 pa-info@sg.pepperl-fuchs.com

PEPPERL+FUCHS

Technical Data

Installation position	see technical information (TI)
Ambient conditions	
Ambient temperature	-40 ... 70 °C (-40 ... 158 °F)
Storage temperature	-40 ... 85 °C (-40 ... 185 °F)
Shock resistance	a = 300 m/s ² = 30 g, 3 planes x 2 directions x 3 shocks x 18 ms, as per test Ea
Vibration resistance	a(RMS) = 50 m/s ² , ASD = 1.25 (m/s ²) ² /Hz, f = 5 to 2000 Hz, t = 3 x 2 h
Process conditions	
Medium temperature	-40 ... 150 °C (-40 ... 302 °F)
Process pressure (static pressure)	-1 ... +40 bar (-14.5 ... +580 psi)
State of aggregation	liquid
Density	min. 0.7 g/cm ³
Viscosity	1 ... 10000 mPa/s, dynamic viscosity
Solid contents	< Ø5 mm
Mechanical specifications	
Degree of protection	IP65/IP67 , NEMA 4X
Connection	M12 connector, 4-pin
Material	process connection and short tube: stainless steel 316L (1.4401/1.4435) tuning fork: stainless steel 316L housing cover and connector: PPSU
Surface quality	R _a < 3.2 µm
Mass	approx. 140 g
Process connection	thread G1/2 to ISO 228
Indication and operation	
Display elements	The LED display is on the connection side. - green LED: indication of ready to operate - red LED: fault indication - yellow LED: operating mode indication
Function test	function test with test magnet (optional accessory)
Certificates and approvals	
CSA approval	cCSAus Listed, General Purpose
Overspill protection	see approval (ZE)
General information	
Supplementary documentation	technical information (TI) manual (BA) approval (ZE)
Supplementary information	Statement of Conformity, Declaration of Conformity, Attestation of Conformity and instructions have to be observed where applicable. For information see www.pepperl-fuchs.com .
Accessories	
Designation	see technical information (TI)

Release date: 2023-12-18 Date of issue: 2023-12-18 Filename: 275573-100029_eng.pdf