

Ultrasonic sensor

UC1500-F65-E8R2-V15

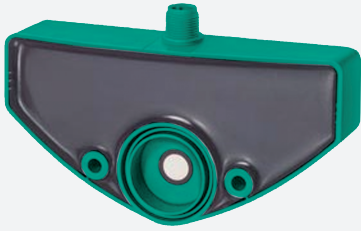

- Level indication
- 2 switch outputs
- Program input
- Programmable by means of Interface (see accessories) and SONPROG
- Synchronization options
- Temperature compensation



Dimensions

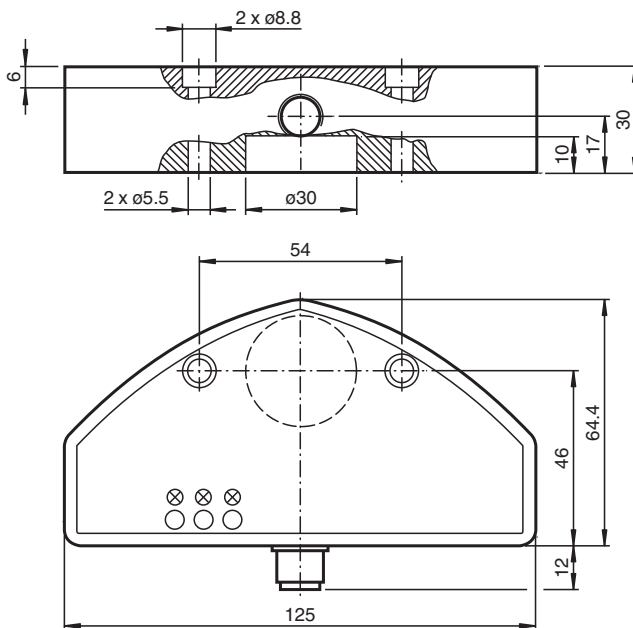

Technical Data

General specifications

Sensing range	200 ... 1500 mm
Adjustment range	200 ... 1500 mm
Dead band	0 ... 200 mm
Standard target plate	20 mm x 20 mm
Transducer frequency	approx. 200 kHz

Nominal ratings

Time delay before availability	t_v	250 ms
--------------------------------	-------	--------

Limit data

Permissible cable length	max. 300 m
--------------------------	------------

Release date: 2023-02-13 Date of issue: 2023-02-13 Filename: 235139_eng.pdf

Refer to "General Notes Relating to Pepperl+Fuchs Product Information".

Pepperl+Fuchs Group
www.pepperl-fuchs.com

USA: +1 330 486 0001
fa-info@us.pepperl-fuchs.com

Germany: +49 621 776 1111
fa-info@de.pepperl-fuchs.com

Singapore: +65 6779 9091
fa-info@sg.pepperl-fuchs.com

PF PEPPERL+FUCHS

Technical Data

Indicators/operating means		
LED green		Power on
LED yellow 1		solid: switching state switch output 1 flashing: misadjustment
LED yellow 2		solid: switching state switch output 2 flashing: misadjustment
Electrical specifications		
Rated operating voltage	U_e	24 V DC
Operating voltage	U_B	12 ... 30 V (including ripple) In supply voltage interval 12 ... 20 V sensitivity reduced to 20% ... 0%
Ripple		≤ 10 %
No-load supply current	I_0	≤ 60 mA
Input		
Input type		1 program input Teach-In of S_{min}
Input voltage		≤ Operating voltage
Level		low level : 0 ... 3 V (Teach-In active) high level : ≥ 15 V (Teach-In inactive)
Pulse length		≥ 150 ms
Output		
Output type		2 switch outputs PNP, NO
Rated operating current	I_e	150 mA , short-circuit/overload protected
Default setting		Switching distance "full", S_{max} : 250 mm Switching distance "empty", S_{min} : 1400 mm Switching hysteresis "full", H_{Smax} : 50 mm Switching hysteresis "empty", H_{Smin} : 100 mm average value "full", M_{Smax} : 20 average value "empty", M_{Smin} : 110
Voltage drop	U_d	≤ 3 V
Switch-on delay	t_{on}	110 ms
Repeat accuracy		± 2 mm
Off-state current	I_r	0.01 mA
Temperature influence		≤ ± 1.5 %
Compliance with standards and directives		
Standard conformity		
Standards		EN IEC 60947-5-2:2020 IEC 60947-5-2:2019
Approvals and certificates		
UL approval		cULus Listed, General Purpose
CCC approval		CCC approval / marking not required for products rated ≤36 V
Ambient conditions		
Ambient temperature		-25 ... 70 °C (-13 ... 158 °F)
Storage temperature		-40 ... 85 °C (-40 ... 185 °F)
Shock resistance		30 g , 11 ms period
Vibration resistance		10 ... 55 Hz , Amplitude ± 1 mm
Mechanical specifications		
Connection type		Connector plug M12 x 1 , 5-pin
Degree of protection		IP65
Material		
Housing		PBT
Transducer		epoxy resin/hollow glass sphere mixture; polyurethane foam
Installation position		any position
Mass		500 g

Release date: 2023-02-13 Date of issue: 2023-02-13 Filename: 235139_eng.pdf

Connection

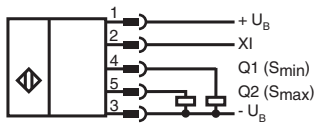

Connection Assignment



Wire colors in accordance with EN 60947-5-2

1	BN	(brown)
2	WH	(white)
3	BU	(blue)
4	BK	(black)
5	GY	(gray)

Characteristic Curve

Characteristic response curve

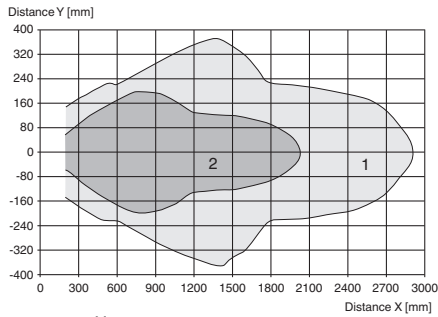

Curve 1: flat surface 100 mm x 100 mm
 Curve 2: round bar, Ø 25 mm



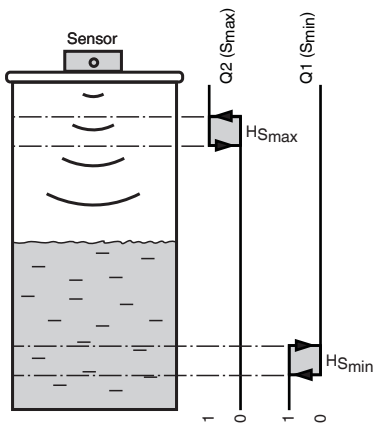

Release date: 2023-02-13 Date of issue: 2023-02-13 Filename: 235139_eng.pdf

Characteristic Curve

Function of the switching outputs



Accessories

	V15-G-2M-PUR	Female cordset single-ended M12 straight A-coded, 5-pin, PUR cable grey
	V15-G-2M-PVC	Female cordset single-ended M12 straight A-coded, 5-pin, PVC cable grey
	V15-W-2M-PVC	Female cordset single-ended M12 angled A-coded, 5-pin, PVC cable grey
	3RX4000-PF	PC interface

Additional Information

Applications

The design and functionality makes this sensor best suitable for level detection applications in small containers or tanks. The device provides 2 switching outputs Q1 (S_{min}) and Q2 (S_{max}). Special distances can be assigned to each of them - e. g. the minimum and maximum levels in a tank can be evaluated and displayed. The parameters can be programmed with SONPROG or with an automatic setup (Teach-In).

Mounting and Connection

All parts are accommodated in a fully enclosed housing. The ultrasonic transducer is set back in the housing, so it is protected. Because of the built-in sealing the sensor can be used as a closure with integrated level detection. The opening of the tank must have a diameter of 26 mm. The sensor is fixed by means of two M5 screws. The sensor has a 5 pin M12 x 1 connector. The BERO has built-in polarity reversal as well as short-circuit and overload protection. Where there is electrical interference, shielded cables are recommended.

Setup

The two ranges, the associated hysteresis and the average value are preset at the factory (see technical data). The parameters can be programmed with SONPROG or with an automatic setup (teach-in). Teach-in can be done by means of the keys of the interface (accessories) or the function input XI.

Automatic Setup (Teach-in)

With this function the minimum level S_{min} can be set. The following steps must be performed in the correct order:

1. Fill the tank up to the required minimum level or place an object at the required distance.
2. Apply "low" signal (0 to 3 V) to the function input XI - e.g. connect XI via a key to 0 V, or connect it via a PLC to "LOW". The LED " S_{min} " flashes, then. The sensor is disabled; it's learning the distance. The signal duration must be at least 150 ms.
3. Remove signal from XI - e.g. disconnect it from the function input XI, connect it to $+U_B$ or connect it via a PLC to "HIGH").

Important! As long as the function input XI is connected to "low", the sensor is disabled.

SONPROG

With SONPROG the following parameters can be programmed:

- Start or end of both switching ranges S_{min} and S_{max}
- Hysteresis (HS_{max} , HS_{min})
- Blind zone
- Sensing range
- Average value
- Switching output S_{min} NC / NO

Customer specific programming is available on request.

Operation

The level of liquid inside a tank is detected within the sensing range. If the level reaches one of the two switching levels (S_{min} , S_{max}), then the corresponding output will be set active. Both switching levels are equipped with a switching hysteresis (HS_{min} , HS_{max}). The switching status of each output is indicated by the corresponding yellow LED. If the filling level is in between the 2 switching levels, both of the outputs are in off state. Objects inside the blind zone will cause error signals. Therefore the user has to mount the sensor that way that the level cannot be inside the blind zone.