

Radar sensor

MWC25M-L2M-B16-V15



- CANopen interface
- Sensing range up to 25 m
- Degree of protection IP68 / IP69
- High EMC resistance
- Sensor head bidirectional and rotatable
- Robust metall fastening

Radar sensor for distance and velocity measuring up to 25 m sensing range, with M12 connector



Function

The radar sensor series MWC25M with CANopen interface for medium distances up to 25 m range is optimized for use in industrial applications. Its compact cubic housing of the L2 series is proven in many industrial areas due to its high robustness. Via Service Data Objects (SDOs), you can directly parameterize the radar sensor optimally for your application. Alternatively, parameterization with extended functionality is also possible using the FDT framework program PACTware and a DTM. This allows you to additionally use various evaluation and filter settings for distance and velocity values. The radar sensor operates according to the frequency modulated continuous wave (FMCW) method in the ISM band at 122 ... 123 GHz, approved for industrial use. In doing so, it emits a continuous radar signal that is varied over the frequency range of the ISM band. With this method, the sensor is able to reliably detect the distance and velocity of static and moving objects. When measuring velocity, the radar sensor detects the velocity of an object in the radial direction only, without measuring tangential velocities or velocity parts.

Dimensions

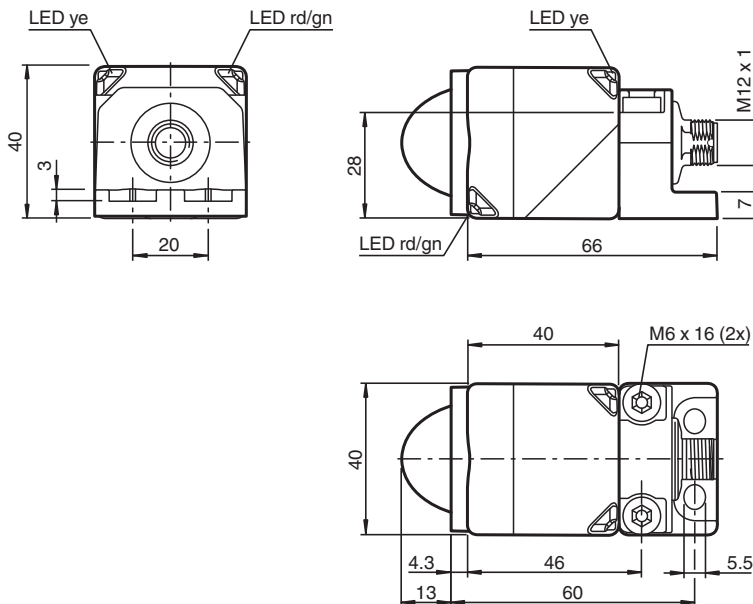

Technical Data

General specifications

Measuring technology	FMCW
----------------------	------

Release date: 2024-01-03 Date of issue: 2024-01-03 Filename: 70134318-100000_eng.pdf

Refer to "General Notes Relating to Pepperl+Fuchs Product Information".

Pepperl+Fuchs Group
www.pepperl-fuchs.com

USA: +1 330 486 0001
fa-info@us.pepperl-fuchs.com

Germany: +49 621 776 1111
fa-info@de.pepperl-fuchs.com

Singapore: +65 6779 9091
fa-info@sg.pepperl-fuchs.com

PF PEPPERL+FUCHS

Technical Data

Measured variable		distance velocity
Measurement range		
Distance		0.5 ... 25 m
Velocity		0.1 ... 80 m/s
Dead band		0 ... 0.5 m
Standard target plate		corner reflector 100 mm edge length
Working frequency		122.25 ... 123 GHz
Opening angle		< 12 ° (see characteristic curve)
Transmitter radiated power (EIRP)		< +20 dBm
Sampling rate		1 ... 200 Hz , programmable
Nominal ratings		
Linearity error		< ± 0.1 % of full-scale value (linearity error incl. temperature drift)
Repeat accuracy	R	1 mm
Resolution		distance 1 mm velocity 0.01 m/s
Time delay before availability	t _v	≤ 400 ms
Functional safety related parameters		
MTTF _d		310 a
Mission Time (T _M)		20 a
Diagnostic Coverage (DC)		up to 60 % (see application report)
Indicators/operating means		
LED yellow		object within measuring range
LED red/green		CANopen status display
Electrical specifications		
Operating voltage	U _B	9 ... 32 V
No-load supply current	I ₀	≤ 100 mA
Power consumption	P ₀	typ. 0.4 W , max. 1 W
Interface		
Interface type		CANopen
Process data		distance velocity signal quality cycle counter
Node ID		1 ... 127 , programmable
Transfer rate		125 kBit/s , 250 kBit/s , 500 kBit/s , 800 kBit/s , 1 MBit/s , programmable
Termination		external
Compliance with standards and directives		
Standard conformity		
Standards		EN 301489-1 EN 301489-3 EN 305550-1 EN 62368-1 EN 62311
Approvals and certificates		
UL approval		cULus
FCC approval		CFR Title 47, Part 15 FCC ID: IRE-MWL2A
ISED approval		IC ID: 7037A-MWL2A HVIN/PMN: MWL2A
Ambient conditions		
Ambient temperature		-40 ... 70 °C (-40 ... 158 °F)
Storage temperature		-40 ... 85 °C (-40 ... 185 °F)
Mechanical specifications		
Connection type		Connector plug
Degree of protection		IP68 / IP69
Material		

Release date: 2024-01-03 Date of issue: 2024-01-03 Filename: 70134318-100000_eng.pdf

Refer to "General Notes Relating to Pepperl+Fuchs Product Information".

 Pepperl+Fuchs Group
www.pepperl-fuchs.com

 USA: +1 330 486 0001
fa-info@us.pepperl-fuchs.com

 Germany: +49 621 776 1111
fa-info@de.pepperl-fuchs.com

 Singapore: +65 6779 9091
fa-info@sg.pepperl-fuchs.com

 **PEPPERL+FUCHS**

Technical Data

Housing	PA-GF35 powder coated metal mounting flange
Radome	PTFE
Connector	
Threading	M12 x 1
Number of pins	5
Mass	180 g
Dimensions	
Height	40 mm
Width	40 mm
Length	83.3 mm
Factory settings	
Sampling rate	50 Hz
Node ID	16
Transfer rate	250 kBit/s

Connection

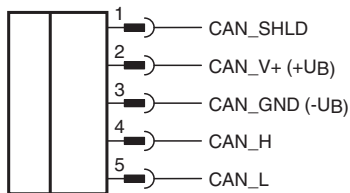

Connection Assignment

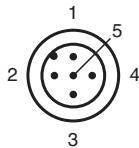

Release date: 2024-01-03 Date of issue: 2024-01-03 Filename: 70134318-100000_eng.pdf

Refer to "General Notes Relating to Pepperl+Fuchs Product Information".

Pepperl+Fuchs Group
www.pepperl-fuchs.com

USA: +1 330 486 0001
fa-info@us.pepperl-fuchs.com

Germany: +49 621 776 1111
fa-info@de.pepperl-fuchs.com

Singapore: +65 6779 9091
fa-info@sg.pepperl-fuchs.com

Characteristic Curve

Characteristic response curve radar sensor

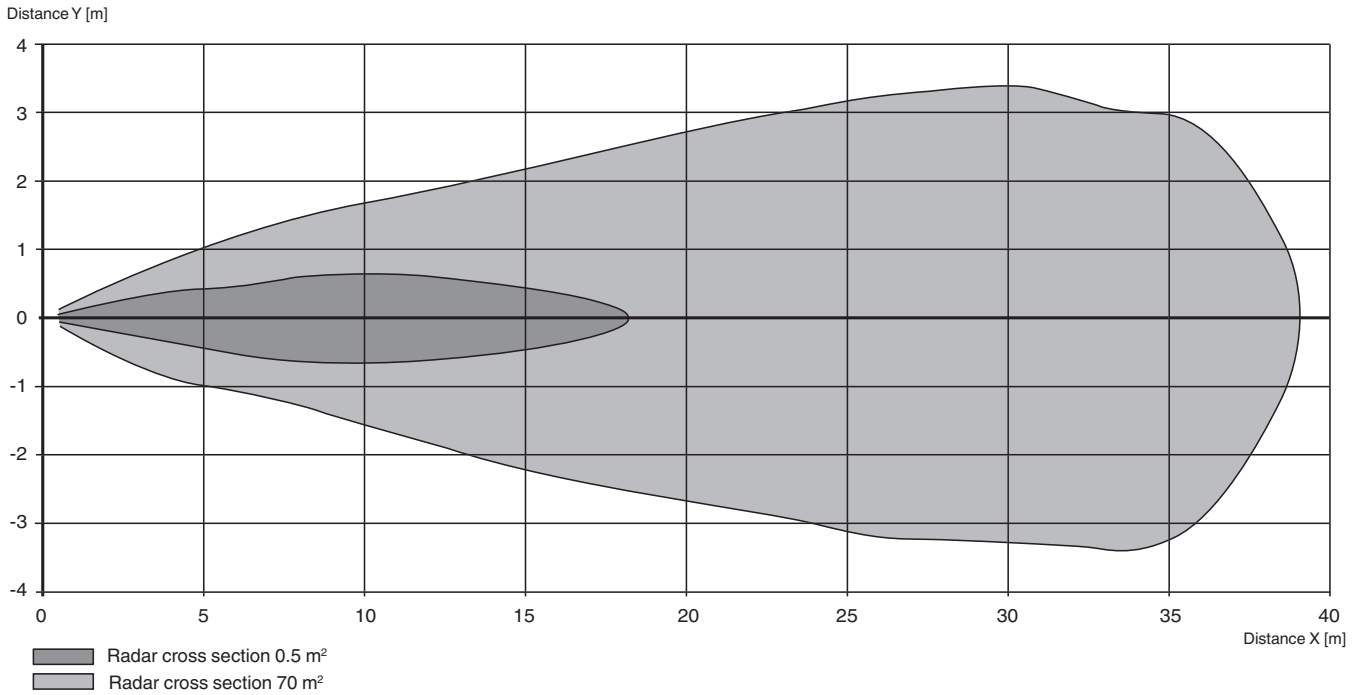

Technical Features

Emitted Interference and Interference Immunity Specifications

Mains-Borne Interference in Accordance with ISO 7637-2									
Pulse	1	2a	2b	3a	3b	4	5	5a	5b
Failure criterion	A	A	C	A	A	A	A	A	A

Interference Immunity	Coupling	Level	Failure Criterion
ISO 11452-2	–	30 V/m	–
EN 61000-4-2	Contact	8 kV	A
	Air	15 kV	A
EN 61000-4-3	–	11 V/m	A
EN 61000-4-4	Direct	1,1 kV	B
	Capacitiv	2,2 kV	B
EN 61000-4-6	–	15 V	A
EN 55011	Contact	Class B	–
EN 55011	Radiation	Class B	–

Accessories

Accessories for this product can be found on the internet at www.pepperl-fuchs.com.

Release date: 2024-01-03 Date of issue: 2024-01-03 Filename: 70134318-100000_eng.pdf