

## Mounting adapter

### MONAD-M08-1,25-M12-1,75/8

- Usable for VIM8\* vibration sensors
- Robust due to stainless steel 1.4404 / AISI 316L (V4A)
- Screw-in thread for simple installation

Mounting adapter for VIM8\* vibration sensors, internal thread M8 x 1.25 x 10, external thread M12 x 1.75, screw-in depth 21

## Dimensions

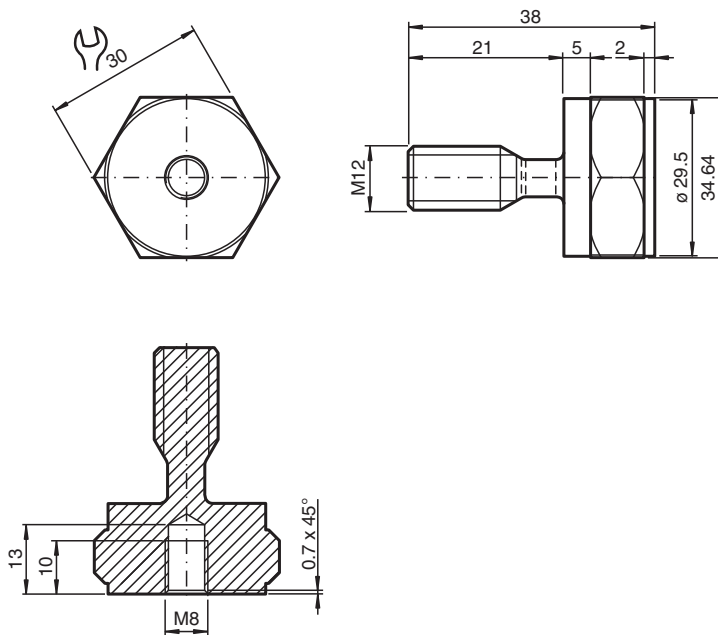

## Technical Data

### General specifications

Suitable components VIM8\* vibration sensors

### Mechanical specifications

External thread for machine mounting

Thread type metric

Thread size M12 x 1.75

Screw-in depth 21 mm

Internal thread for sensor mounting

Thread type metric

**Technical Data**

Thread size		M8 x 1.25
Thread length		10 mm
Length	L	38 mm
Diameter		34.64 mm
Material		Stainless steel 1.4404 / AISI 316L
Mass		110 g

Release date: 2023-05-11 Date of issue: 2023-05-11 Filename: 70146787\_eng.pdf

Refer to "General Notes Relating to Pepperl+Fuchs Product Information".

Pepperl+Fuchs Group  
www.pepperl-fuchs.comUSA: +1 330 486 0001  
fa-info@us.pepperl-fuchs.comGermany: +49 621 776 1111  
fa-info@de.pepperl-fuchs.comSingapore: +65 6779 9091  
fa-info@sg.pepperl-fuchs.com **PEPPERL+FUCHS**