

IO-Link motor control module

ICA-8DIO4M1-G20-IO

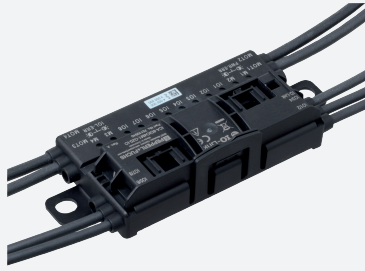

- Inputs for 2- and 3-wire sensors
- Electronic PNP outputs
- Connections for DC roller motors
- Configuration and control via IO-Link
- Function indicator for motors, inputs and outputs

G20 IO-Link module for digital inputs/outputs, 8 inputs and 8 outputs, 4 connections for roller motors



Function

The rollerdrive motor control module ICA-8DIO4M1-G20-IO* is a field module with 8 combined sensor inputs or electronic outputs. The 4 outputs for controlling DC rollerdrive motors are optimized for:

- Interroll EC310.
- Interroll EC5000 24V AI (20W / 35W / 50W)
- Rulmeca BL3
- Itoh Denki PM500XK
- Itoh Denki PM500XC

The compact housing can be mounted directly into support profiles or cable ducts. The power supply U_{PWR} is connected by piercing technology via the black AS-Interface flat cable. The swiveling flat cable guide locks without tools by a snap-fit.

The combined inputs and outputs and the motor outputs are connected using cable outputs with M8 round connectors. The inputs and outputs have 4-pin female connectors with locking nut, the motor outputs have 5-pin snap-on female connectors. IO-Link is connected using a cable output with M12 4-pin round plug connector. The inputs and outputs are supplied via IO-Link. The motor outputs are supplied via U_{PWR} .

The LEDs IO display the current switching state and as well a fault condition of the combined inputs/outputs. The LEDs M display the operating state of the motors (stop/run/fault).

The module is configured via IO-Link.

Dimensions

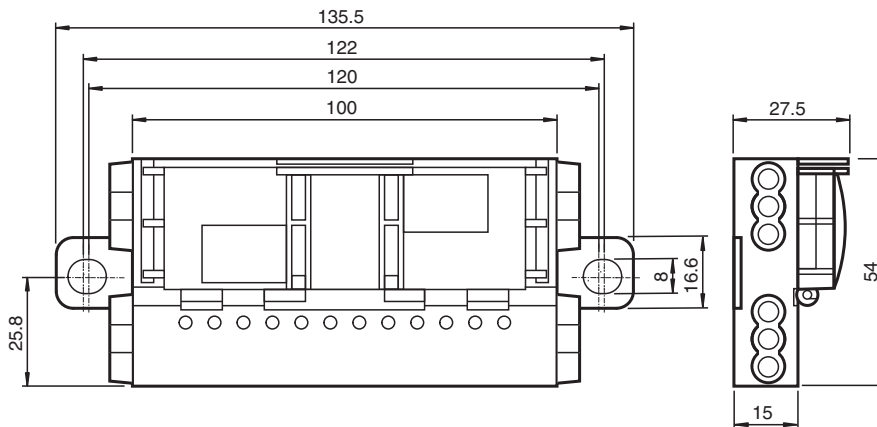

Technical Data

General specifications

UL File Number	E223772 "For use in NFPA 79 Applications only"
MTBF	90 a
Compatible roller motors	Interroll EC310, Interroll EC5000 24V AI (20W / 35W / 50W), Rulmeca BL3, Itoh Denki PM500XK, Itoh Denki PM500XC

Release date: 2023-11-07 Date of issue: 2023-11-07 Filename: 70110940_eng.pdf

Refer to "General Notes Relating to Pepperl+Fuchs Product Information".

Pepperl+Fuchs Group
www.pepperl-fuchs.com

USA: +1 330 486 0001
fa-info@us.pepperl-fuchs.com

Germany: +49 621 776 1111
fa-info@de.pepperl-fuchs.com

Singapore: +65 6779 9091
fa-info@sg.pepperl-fuchs.com

PEPPERL+FUCHS

Technical Data

Indicators/operating means		
LED yellow/red		IO1 ... IO8: IO-Link status MOT1 ... MOT4: motor status
Electrical specifications		
Auxiliary voltage	U_{PWR}	18 ... 30 VDC PELV Max. 10 A Current limitation of the supply max. 30 A For UL: Z-type miniature circuit breaker in accordance with UL 1077, max. 20 A, required
Operating voltage	U_B	18 ... 30 V DC, PELV Max. 2.5 A (IO-Link) Current limitation of the supply max. 4 A
No-load supply current	I_0	≤ 25 mA
Operating current	I_B	max. 2.5 A
Interface		
Interface type		IO-Link
IO-Link revision		1.1
Device profile		Identification and Diagnosis - I&D
Process data		8 byte inputs (STD/EXT) 6 byte outputs (STD) 18 byte outputs (EXT)
Vendor ID		1 (0x0001)
Device ID		Rev. A: 984066 (0x0F0402) (STD) - default 984065 (0x0F0401) (EXT) Rev. B: 984066 (0x0F0402) (STD) 984065 (0x0F0401) (EXT) 984070 (0x0F0406) (STD) - default 984069 (0x0F0405) (EXT)
Data transfer rate		COM3 (230.4 kbits/s)
Min. cycle time		1.2 ms (STD) 2 ms (EXT)
SIO mode support		no
Compatible master port type		Class A
Input		
Number/Type		8 Inputs for 3-wire sensors (PNP), DC (IO1 ... IO8)
Supply		from IO-Link
Current loading capacity		200 mA , overload and short-circuit protected
Input current		≤ 5 mA (limited internally)
Switching point		Type 3 according to IEC 61131-2
Output 1		
Number/Type		8 electronic outputs, PNP (IO1 ... IO8), overload proof and short-circuit proof
Supply		from IO-Link
Current		200 mA per output
Voltage		≥ (U_e - 1.5 V)
Output 2		
Number/Type		4 outputs for DC roller motors (MOT1 ... MOT4)
Supply		via U_{PWR}
Current loading capacity		3.5 A (continuous), 5 A (< 2 s), max. 7.5 A (< 0.3 s) per motor Total current (continuous) max. 10 A per device
Overload protection		Fuse 5 A, $I^2t = 53.7 \text{ A}^2\text{s}$ per motor
Signal level		Speed: $U_S = 0.3 \dots 10 \text{ V}$ in no-load operation $R_i = 5.6 \text{ k}\Omega$, $R_{LOAD} \geq 35 \text{ k}\Omega$ Direction of rotation: Digital output PNP $U_D \text{ low} = \text{high resistance}$ $U_D \text{ high} \geq (U_{PWR} - 0.5 \text{ V})$ Current-carrying capacity 400 mA, overload proof and short-circuit proof
Fault level		Motor fault: Digital input NPN 0 (no error) ≥ 125 μA 1 (error) ≤ 25 μA
Output 3		
Number/Type		4 electronic outputs, PNP (DIR/OUT1 ... DIR/OUT4), overload and short-circuit proof

Release date: 2023-11-07 Date of issue: 2023-11-07 Filename: 70110940_eng.pdf

Technical Data

Supply	via U _{PWR}
Current	400 mA per output
Voltage	≥ (U _{PWR} - 0.5 V)
Directive conformity	
Electromagnetic compatibility	
Directive 2014/30/EU	EN 61326-1:2013 EN 55011:2016
Standard conformity	
Degree of protection	EN 60529:2000
Fieldbus standard	EN 61131-9:2013
Input	EN 61131-2:2007
Communication interface	IEC 61131-9 / IO-Link V1.1.2
Emitted interference	EN 61000-6-4:2007
Noise immunity	EN 61000-6-2:2005, EN 61326-1:2006
Ambient conditions	
Ambient temperature	-25 ... 70 °C (-13 ... 158 °F)
Storage temperature	-25 ... 70 °C (-13 ... 158 °F)
Relative humidity	85 % non-condensing
Climatic conditions	For indoor use only
Altitude	≤ 2000 m above MSL
Shock and impact resistance	30 g, 11 ms in 6 spatial directions, 3 shocks 10 g, 16 ms in 6 spatial directions, 1000 shocks
Vibration resistance	0.35 mm / 5 g 5 ... 500 Hz
Pollution degree	2
Mechanical specifications	
Degree of protection	IP54 according to EN 60529
Connection	24 V power (PWR): Piercing technology, black flat cable IO-Link: M12 round plug connector in accordance with EN 61076-2-101, LM type (4-pin, connector contacts, screw-locking, A-coded) Female connector: LF type or similar Inputs/outputs (IO), motors (MOT): M8 round plug connector in accordance with EN 61076-2-104 IO: LF type (4-pin, bushing contacts, screw-locking, A-coded) Female connector: LM type or similar MOT: NF type (5-pin, bushing contacts, snap-locking, B-coded) Female connector: NM type or similar
Mass	310 g
Mounting	2 clips with Ø 8 mm drill hole The module must be secured to a solid, continuous surface using the two lugs
Cable length	1 m (IO-Link) 0.5 m (IO1/2, IO5/6), 0.65 m (IO3/4, IO7/8) 0.5 m (MOT1, MOT3); 0.4 m (MOT2, MOT4) max. 10 m
Note	The flat cable routing is designed for 100 actuation cycles

Release date: 2023-11-07 Date of issue: 2023-11-07 Filename: 70110940_eng.pdf

Connection

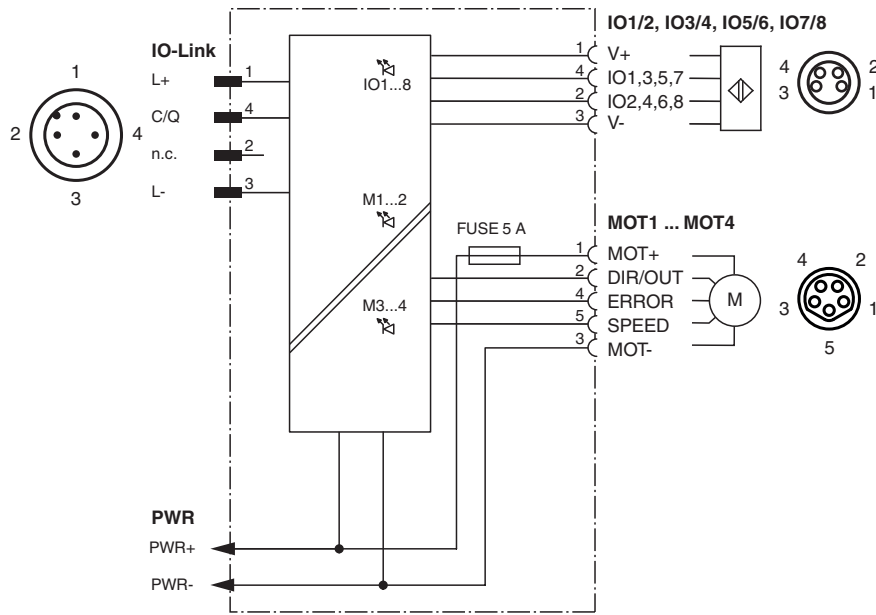

Indication

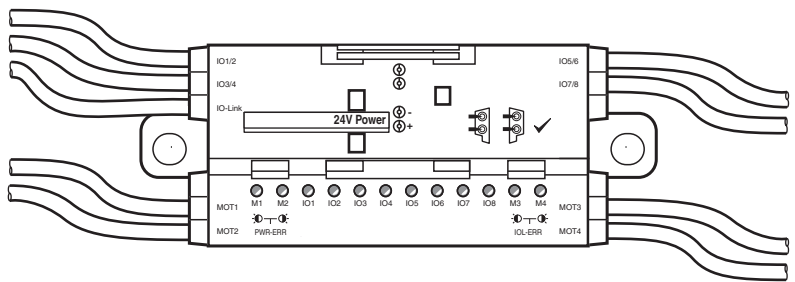

Release date: 2023-11-07 Date of issue: 2023-11-07 Filename: 70110940_eng.pdf