



Operating instructions  
Photoelectric distance sensor

**GB**

**OGD25x**  
**OGD55x**

## Contents



1	Preliminary note	4
1.1	Symbols used	4
1.2	Warnings used	4
2	Safety instructions	5
3	Intended use	6
3.1	General notices	6
3.2	Applications	6
4	Function	7
4.1	Assigning measurement parameters to a switching output	7
4.2	Output function hysteresis	7
4.2.1	Hysteresis function – distance	7
4.2.2	Hysteresis function – reflectivity	8
4.2.3	Dynamic hysteresis	9
4.3	Output function window	9
4.3.1	Window function – distance	9
4.3.2	Window function – reflectivity	10
4.4	Analogue output	11
4.4.1	Current output 4...20 mA	11
4.4.2	Voltage output 0...10 V	12
4.5	Switching off the laser	12
4.6	Operating modes	12
4.6.1	Switching mode	12
4.6.2	IO-Link	12
5	Installation	14
5.1	Installation conditions	14
5.2	Mounting accessories	14
5.3	Installation instructions	14
5.3.1	Avoidance of soiling and ambient light	14
5.3.2	Sensor alignment for a moving object	14
6	Electrical connection	16
6.1	PNP/NPN selection	16
6.2	Operation with IO-Link master	17
7	Operating and display elements	18
8	Set-up	19
9	Menu	20
9.1	Hysteresis function (distance and reflectivity)	20
9.2	Window function (distance and reflectivity)	21
9.3	Analogue output for OUT2 (distance and reflectivity)	22
9.4	Extended functions – EF	23
10	Operating modes	24
10.1	Run mode	24
10.2	Display mode	24
10.3	Programming mode	24
11	Parameter setting	25
11.1	General parameter setting	25
11.1.1	Setting a parameter value	25
11.1.2	Changing from menu level 1 to the menu level 2	25
11.1.3	Locking / unlocking the device	25
11.1.3.1	Parameter setting via the device keys	26
11.1.3.2	Parameter setting via IO-Link	26
11.2	Configuring the basic settings	26
11.2.1	Output configuration	26
11.2.1.1	Parameter setting via the device keys	26
11.2.1.2	Parameter setting via IO-Link	27
11.2.2	Measured parameter	27

11.2.2.1	Parameter setting via the device keys	27
11.2.2.2	Parameter setting via IO-Link	27
11.2.3	Object teach for hysteresis function	27
11.2.3.1	Teaching via the device keys	27
11.2.3.2	Teaching via IO-Link	28
11.2.4	Teach – switch point for window function	28
11.2.4.1	Teaching via the device keys	28
11.2.4.2	Teaching via IO-Link	29
11.2.5	Teach – 1-point window function	29
11.2.5.1	Teaching via the device keys	29
11.2.5.2	Teaching via IO-Link	30
11.3	Extended functions	30
11.3.1	Operating modes	30
11.3.1.1	Parameter setting via the device keys	31
11.3.1.2	Parameter setting via IO-Link	31
11.3.2	Setting the delay time for switching outputs	31
11.3.2.1	Parameter setting via the device keys	31
11.3.2.2	Parameter setting via IO-Link	32
11.3.3	Setting a fault suppression time	32
11.3.3.1	Parameter setting via the device keys	32
11.3.3.2	Parameter setting via IO-Link	32
11.3.4	Output logic (PNP/NPN)	32
11.3.4.1	Parameter setting via the device keys	32
11.3.4.2	Parameter setting via IO-Link	33
11.3.5	Sequence modulation – mutual interference	33
11.3.5.1	Parameter setting via the device keys	33
11.3.5.2	Parameter setting via IO-Link	33
11.3.6	Setting the display	34
11.3.6.1	Parameter setting via the device keys	34
11.3.6.2	Parameter setting via IO-Link	34
11.3.7	Setting the display colours	34
11.3.7.1	Parameter setting via the device keys	34
11.3.7.2	Parameter setting via IO-Link	35
11.3.8	Device information	35
11.3.8.1	Display via the device keys	35
11.3.8.2	Display via IO-Link	35
11.3.9	Restoring the factory setting	35
11.3.9.1	Reset via the device keys	35
11.3.9.2	Reset via IO-Link	35
11.4	Additional parameter settings via IO-Link	36
11.4.1	Transmitter configuration	36
11.4.1.1	Parameter setting via IO-Link	36
11.4.2	Unit locking	36
11.4.2.1	Parameter setting via IO-Link	36
12	Display	37
12.1	Devices with switching output	37
12.2	Devices with analogue output	37
13	Maintenance, repair and disposal	39
14	Factory setting	40

# 1 Preliminary note

You will find instructions, technical data, approvals and further information using the QR code on the device / packaging or at [documentation.ifm.com](https://documentation.ifm.com).

## 1.1 Symbols used

- ✓ Requirement
- ▶ Instructions
- ▷ Reaction, result
- [...] Designation of keys, buttons or indications
- Cross-reference
-  Important note  
Non-compliance may result in malfunction or interference.
-  Information  
Supplementary note

## 1.2 Warnings used

---

	<b>ATTENTION</b> Warning of damage to property
	<b>CAUTION</b> Warning of personal injury ▷ Slight reversible injuries may result.

---

## 2 Safety instructions

- The device described is a subcomponent for integration into a system.
  - The system architect is responsible for the safety of the system.
  - The system architect undertakes to perform a risk assessment and to create documentation in accordance with legal and normative requirements to be provided to the operator and user of the system. This documentation must contain all necessary information and safety instructions for the operator, the user and, if applicable, for any service personnel authorised by the architect of the system.
- Read this document before setting up the product and keep it during the entire service life.
- The product must be suitable for the corresponding applications and environmental conditions without any restrictions.
- Only use the product for its intended purpose (→ Intended use).
- If the operating instructions or the technical data are not adhered to, personal injury and/or damage to property may occur.
- The manufacturer assumes no liability or warranty for any consequences caused by tampering with the product or incorrect use by the operator.
- Installation, electrical connection, set-up, operation and maintenance of the product must be carried out by qualified personnel authorised by the machine operator.
- Protect devices and cables against damage.



### CAUTION

Exposure to radiation

- ▷ Injury due to dangerous exposure to radiation
- ▶ Only use the operating and adjusting devices indicated in the operating instructions.



### CAUTION

Visible laser light; LASER CLASS 1.

EN/IEC 60825-1 : 2007 and EN/IEC 60825-1 : 2014 complies with 21 CFR Part 1040 except for deviations pursuant to Laser Notice No. 50, dated June 2007.

Position of the product label

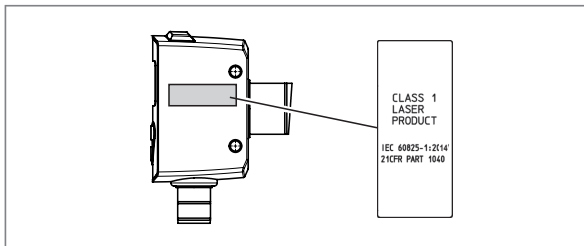

Warning sign



Max. power	< 1.56 mW
Pulse duration	1.25 ns
Average power	< 0.39 mW
Wave length	650 nm

### ATTENTION

The device may cause radio interference in domestic areas. In this case it can be necessary for the user to take appropriate measures.

## 3 Intended use

### 3.1 General notices

The device is used as a photoelectric distance sensor.

The device continuously detects the distance to the object and the reflectivity of the object and generates output signals according to the parameter settings.

- 2 switching outputs are available. They can be set separately. Switch points can either be set or taught.
- The measured values are shown in a 7-segment display and transferred via IO-Link. Two measured values are generated.

#### Measured distance value:

Distance from the front pane of the sensor to the target.

#### Object reflectivity:

Reflective quality of the object.

The reflective quality of an object is angle dependant, e.g. a white Kodak grey card has a reflective quality of approx. 90% at perpendicular light incidence.



The device uses a laser diode as light source and creates a light spot. This makes it possible to detect small objects.

The light spot should hit the object or the background. Intermediate states may lead to faulty measured values.



In the following document, the switching signal channels 1 and 2 are replaced by an "x".  
Example: SP1 / SP2 → SPx

### 3.2 Applications

- The photoelectric distance sensor measures distances from 30...2200 mm and object reflectivities from 0...999 %.
- It has a background suppression of up to 20 m.



The distance between the sensor and the background must be limited to max. 20 m. Otherwise measured values can be ambiguous.

## 4 Function

The device shows the currently measured object distance or alternatively the object reflectivity in the display. It generates output signals according to the parameter setting. Moreover, it provides the process data via IO-Link.

The device is designed for fully bidirectional communication. So the following options are possible:

- Remote display: reading and displaying the current distance / reflectivity.
- Remote parameter setting: reading and changing the current parameter setting.

### 4.1 Assigning measurement parameters to a switching output

The device has two switching outputs, OUT1 / OUT2.

Via the parameters [SEL1] / [SEL2], a measurement parameter can be assigned to each switching output.

e.g.

Parameter	Switching output	Setting	Measured value
[SEL1]	OUT1	[dist]	Distance
[SEL1]	OUT1	[refl]	Reflectivity
[SEL2]	OUT2	[dist]	Distance
[SEL2]	OUT2	[refl]	Reflectivity

### 4.2 Output function hysteresis

The hysteresis keeps the switching status of the output stable if the measured value fluctuates around the switch point. Both outputs (OUT1 and OUT2) can be set and taught as hysteresis function. The switching output (OUT1 and OUT2) states are derived based on the measurement parameters "distance" or "reflectivity". The measurement parameter can be selected individually for each switching output.

#### 4.2.1 Hysteresis function – distance

The selected switch point [SPx] is the set point. The reset point is automatically set above the selected switch point [SPx] by the sensor. The nominal distance between set point and reset point is the hysteresis, it is indicated in the data sheet. The hysteresis depends on the reflectivity of the background.

##### Example Hno

- ① For the output function [Hno] the output switches when the object approaches and when the set point (A) is reached.
- ② When the object is removed again, the output does not switch back before the reset point (B) is exceeded. The reset point (B) is above the set point (A).

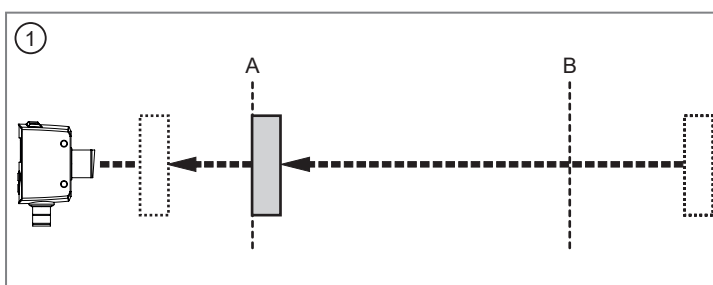

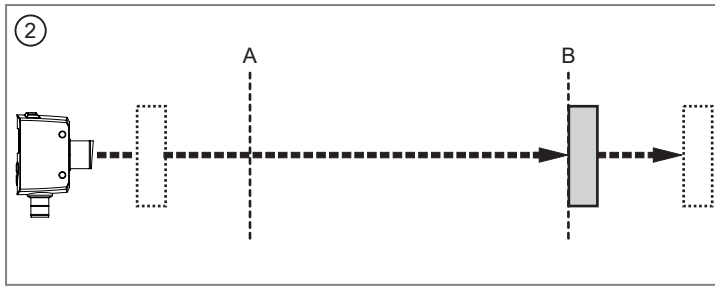

A: Set point

B: Reset point



The object is detected if the switch point (distance) is not reached.

### Switching status of the outputs

Output function	Object distance (D)	Switching status
[Hno]	$D < [SPx]$	Closed
	$D > [SPx] + \text{hysteresis}$	Open
[Hnc]	$D < [SPx]$	Open
	$D > [SPx] + \text{hysteresis}$	Closed

### 4.2.2 Hysteresis function – reflectivity

The selected switch point [SPx] is the set point. The reset point is automatically set below the selected switch point [SPx] by the sensor. The nominal reflectivity difference between set and reset point is the hysteresis which is indicated in the data sheet.

#### Example Hno

For the output function [Hno] the output switches when the object reflectivity increases and when the set point (A) is reached.

When the object gets darker, the output does not switch back before the value is below the reset point (B). The reset point (B) is smaller than the set point (A).

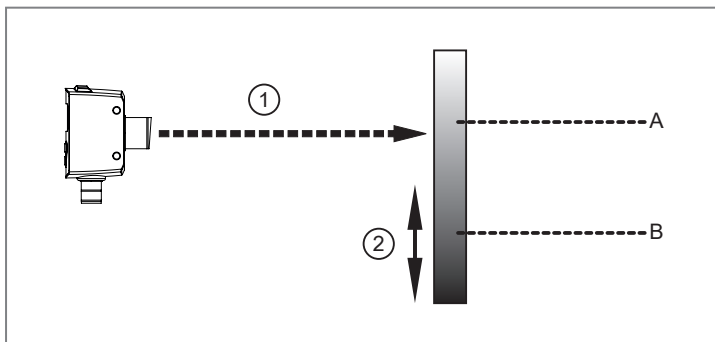

① Laser beam

A: Set point

② Direction of movement of the object

B: Reset point

If the output function [Hnc] has been selected, the set and reset points are reversed. The output switches on if the object reflectivity is decreased. If the object reflectivity is increased, the output switches off.



The object is detected if the switch point (reflectivity) is exceeded.



## Switching status of the outputs

Output function	Object reflectivity (R)	Switching status
[Hno]	$R < [SPx] - \text{hysteresis}$	Open
	$R > [SPx]$	Closed
[Hnc]	$R < [SPx] - \text{hysteresis}$	Closed
	$R > [SPx]$	Open

### 4.2.3 Dynamic hysteresis

The measured values detected by the sensor vary depending on the situation. The highest fluctuation of measured values occurs in case of a small signal to noise ratio. This is the case when very dark targets are detected and when there is very much ambient light. Therefore, the reset point is automatically set by the sensor after the switch point has been selected.

Very dark background = high hysteresis is selected.

Very bright background = small hysteresis is selected.

The minimum distance between object and background is reduced if the background is very bright (e.g. white). A bright background enables the detection of smaller objects.

## 4.3 Output function window

The window function enables the monitoring of a defined acceptable range. Both outputs (OUT1 and OUT2) can be set and taught as window function. The switching output (OUT1 and OUT2) states are derived based on the measurement parameters "distance" or "reflectivity". The measurement parameter can be selected individually for each switching output.



Hystereses set automatically by the sensor ensure that the switching status of the output remains stable at the window limits. Please refer to the data sheets for the hystereses.

### 4.3.1 Window function – distance

It is possible to define an object detection window for output [OU1] / [OU2].

Switches when the object is detected ([OUx] = [Fno])

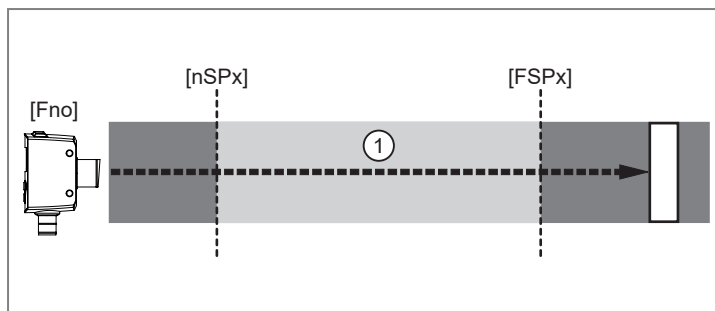

[nSPx]: Switch point "near"

[FSPx]: Switch point "far"



Window

If the measured value is between the switch point "near" [nSPx] and the switch point "far" [FSPx], the output is switched on (if [OUx] = [Fno]).

**Switches off when the object is detected ([OUx] = [Fnc])**

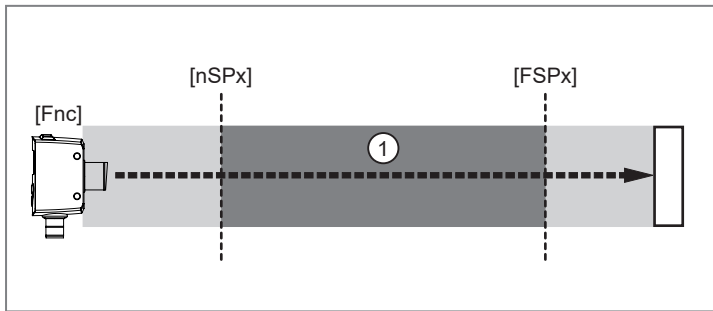



[nSPx]: Switch point "near"

[FSPx]: Switch point "far"

① Window

If the measured value is between the switch point "near" [nSPx] and the switch point "far" [FSPx], the output is switched off (if [OUx] = [Fnc]).

 The parameters [nSPx] and [FSPx] can also be set via the teach function. The reset points are set dynamically by the sensor.

 The minimum distance between [nSPx] and [FSPx] is 1mm.  
 Condition: [nSPx] < [FSPx]  
 e.g. the teaching of [nSPx] > [FSPx] will not be adopted by the sensor.

**Switching status of the outputs**

Output function	Object distance (D)	Switching status
[Fno]	D < [nSPx] D > [FSPx]	Open
	[nSPx] < D < [FSPx]	Closed
[Fnc]	D < [nSPx] D > [FSPx]	Closed
	[nSPx] < D < [FSPx]	Open

**4.3.2 Window function – reflectivity**

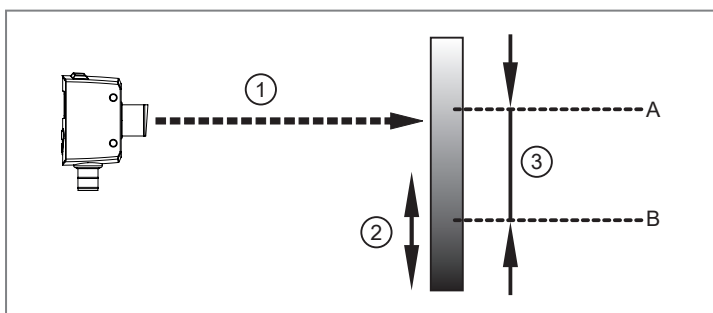

① Laser beam

② Direction of movement of the object

③ Window

A: Switch point "bright" = [bSPx]

B: Switch point "dark" = [dSPx]

**Switches when the object is detected ([OUx] = [Fno])**

If the measured value is between the switch point "bright" [bSPx] and the switch point "dark" [dSPx], the output is switched on (if [OUx] = [Fno]).

**Switches off when the object is detected ([OUx] = [Fnc])**

If the measured value is between the switch point “bright” [bSPx] and the switch point “dark” [dSPx], the output is switched off (if [OUx] = [Fnc]).

 The parameters [bSPx] and [dSPx] can also be set via the teach function. The reset points are set dynamically by the sensor.

 The minimum distance between [bSPx] and [dSPx] is 1 %.  
Condition: [dSPx] < [bSPx]  
e.g. the teaching of [dSPx] > [bSPx] will not be adopted by the sensor.

**Switching status of the outputs**

Output function	Object reflectivity (R)	Switching status
[Fno]	R < [dSPx] R > [bSPx]	Open
	[dSPx] < R < [bSPx]	Closed
[Fnc]	R < [dSPx] R > [bSPx]	Closed
	[dSPx] < R < [bSPx]	Open

**4.4 Analogue output**

A current or voltage output can be configured for the output [OU2].

- Current output 4...20 mA
- Voltage output 0...10 V

 The analogue function is only available on selected devices. → Technical data sheet

**4.4.1 Current output 4...20 mA**

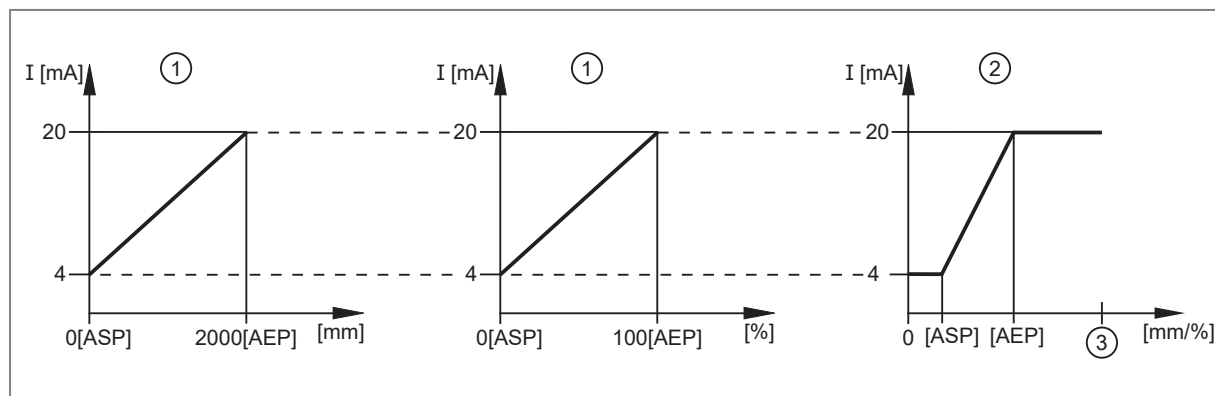

- ① Factory setting
- ② Measuring range scaled
- ③ Final value of the measuring range

In the set measuring range the output signal is between 4 and 20 mA.

Faults are also displayed:

- Faults at [SELx] = [dist]:
  - Too much light or object too near: 3.5 mA for rising edge ([ASP] < [AEP]), 20.5 mA for falling edge ([ASP] > [AEP]).
  - Object too far or no object present: 20.5 mA for rising edge; 3.5 mA for falling edge.

- Faults at [SELx] = [refl]:
  - Too much light: 20.5 mA for rising edge ([ASP]<[AEP]), 3.5 mA for falling edge ([ASP] > [AEP]).
  - No object available: 3.5 mA for rising edge; 20.5 mA for falling edge.

### 4.4.2 Voltage output 0...10 V

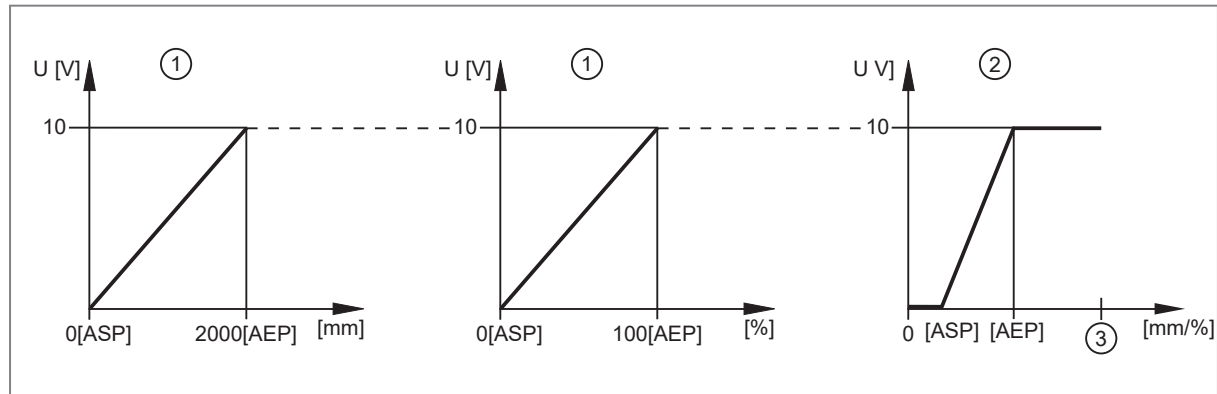

- ① Factory setting
- ② Measuring range scaled
- ③ Final value of the measuring range

In the set measuring range the output signal is between 0 and 10V.

## 4.5 Switching off the laser

The laser can be switched off via the input on pin 5 and via IO-Link.

Input signal on pin 5		Laser
PNP	NPN	
Low / not used	High / not used	On
High	Low	Off

## 4.6 Operating modes

### 4.6.1 Switching mode

In switching mode, the sensor is directly connected to the process control unit and transmits the state via the switching output.

### 4.6.2 IO-Link

IO-Link is a communication system for connecting intelligent sensors and actuators to automation systems. IO-Link is standardised in the IEC 61131-9 standard.

 General information on IO-Link at [io-link.ifm](http://io-link.ifm)

 Input Output Device Description (IODD) with all parameters, process data and detailed descriptions of the device at [documentation.ifm.com](http://documentation.ifm.com)

IO-Link offers the following advantages:

- Interference-free transmission of all data and process values

- Parameter setting in the running process or presetting outside the application
- Parameters for identifying the connected devices in the system
- Additional parameters and diagnostic functions
- Automatic backup and restore of parameter sets in case of device replacement (data storage)
- Logging of parameter sets, process values and events
- Device description file (IODD - Input Output Device Description) for easy project planning
- Standardised electrical connection
- Remote maintenance

## 5 Installation

### 5.1 Installation conditions

► Install the device so that the object to be detected is within the sensor's detection zone.



Reflecting objects in the direct beam path of the sensor – also outside the detection zone – are to be avoided by the customer (tilt the sensor by 10°). Otherwise the measured values can be distorted.

Detection zone → Data sheet

### 5.2 Mounting accessories

The device is supplied with mounting accessories.

Device	Mounting accessories	Part No.
OGD55x	2x metal lock nuts	E10027
OGD25x	2x plastic lock nuts	E10026

Suitable mounting accessories can be found at [www.ifm.com](http://www.ifm.com).

### 5.3 Installation instructions

#### 5.3.1 Avoidance of soiling and ambient light

Preferably align photoelectric sensors with the front lens facing downwards or parallel to the earth's surface.

Background:

- Photoelectric sensors are sensitive to direct radiation of light sources. Everyday light sources (lamps, sun) radiate from above.
- Photoelectric sensors react sensitively to soiling, as it reduces the excess gain.



Dust deposits can be reduced by downwards or sideways orientation. This allows for longer cleaning intervals.



Make sure that sensors installed with their front lens facing upwards are not oriented towards roof windows or ceiling lamps.

#### 5.3.2 Sensor alignment for a moving object

The sensor has to be installed in a way to ensure that the object is moved into the detection zone of the sensor from the side or from the front.

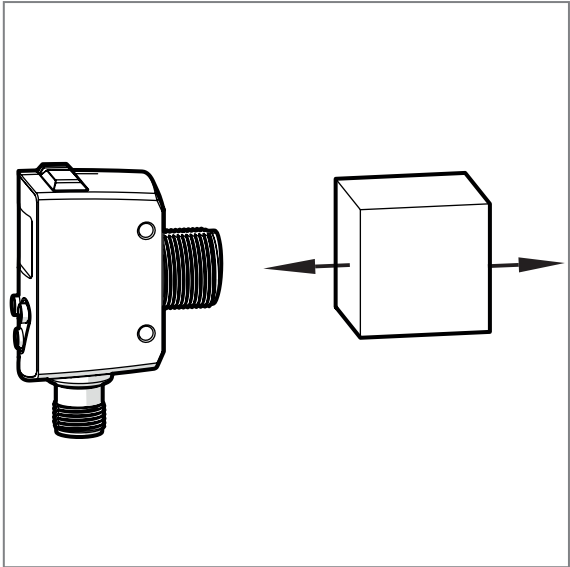
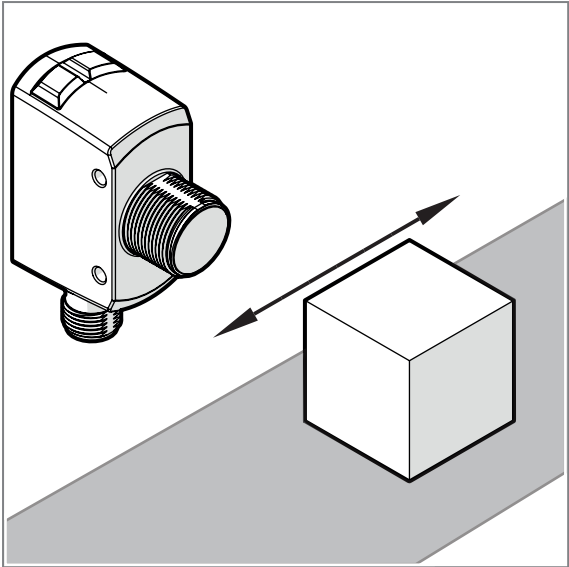

## 6 Electrical connection



The device must be connected by a qualified electrician.

- ▶ Observe the national and international regulations for the installation of electrical equipment.
- ▶ Ensure voltage supply according to SELV, PELV.  
OGD25x / OGD55x: cULus, Supply Class 2

▶ Disconnect power.

▶ Connect the device as follows:

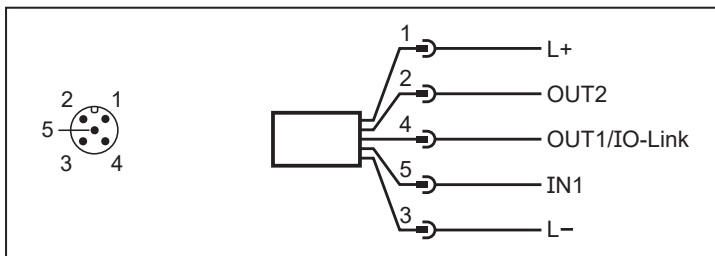

- 1: L+
- 2: OUT2: switching output or analogue output
- 3: L-
- 4: OUT1: switching output or IO-Link
- 5: IN1: laser on / off

### 6.1 PNP/NPN selection

Pins 2 and 4 can be switched between PNP and NPN logic.

The setting cannot be made for individual pins, but applies to all pins.

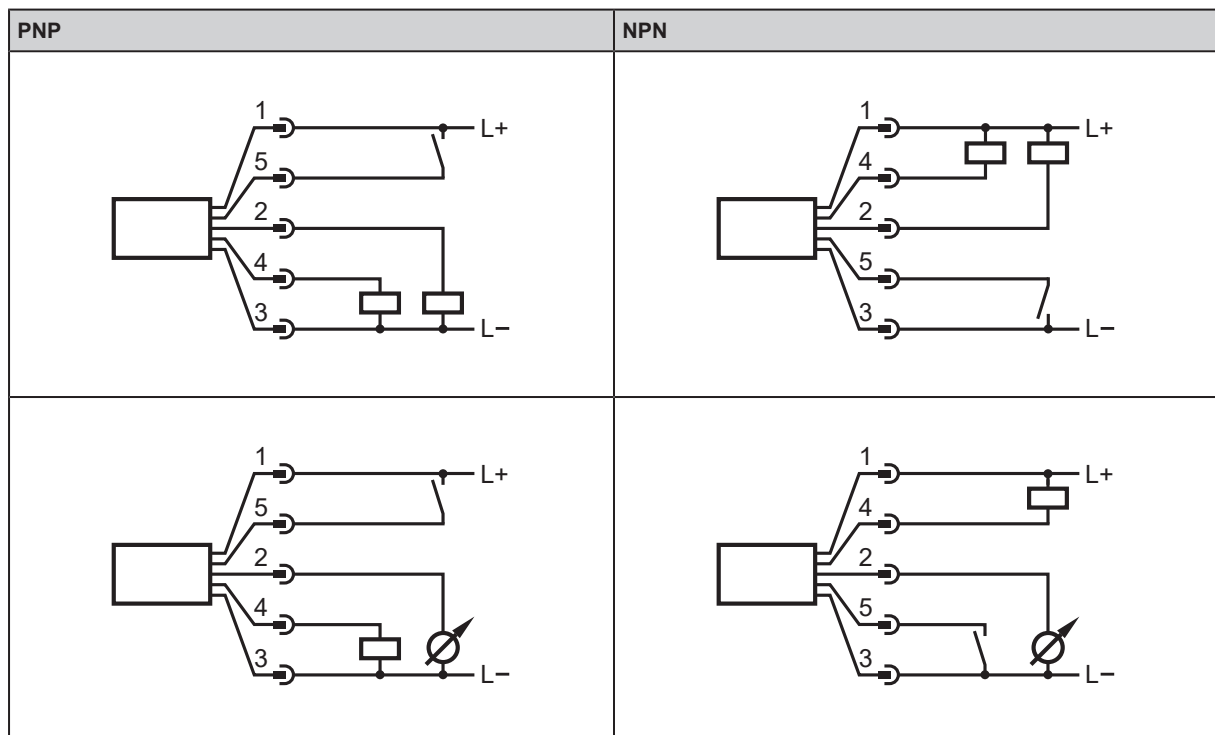

- 1: L+
- 2: OUT2: switching output or analogue output
- 3: L-
- 4: OUT1: switching output or IO-Link
- 5: IN1: laser on / off



## 6.2 Operation with IO-Link master

The unit is compatible with IO-Link master port class A (type A).



For operation with IO-Link master port class B (type B) observe the following:

As a standard, the unit is not compatible with master port class B (type B). Pin 2 and pin 5 are used for manufacturer-specific functions. That means that the main supply voltage of the unit and the additional voltage supply (master port class B on pins 2/5) are not electrically isolated.

With the following configuration, the unit can be used with master port class B:

- Connect unit and IO-Link master via 3 wires: Connect pins 1, 3 and 4 of the unit with the IO-Link master (do not connect pins 2 and 5).

## 7 Operating and display elements

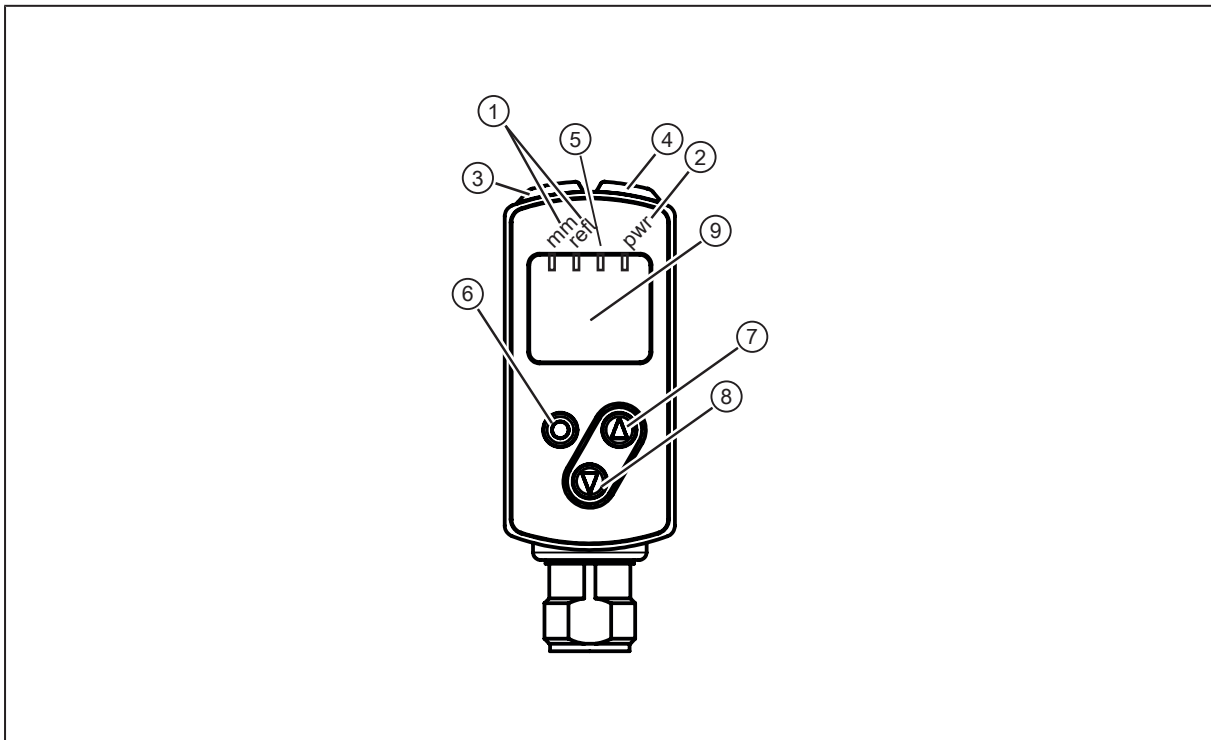

1:	2x green LED	Status LED = set display unit (cm, mm, refl)
2:	1x green LED	Status LED = power
3:	1x yellow LED	Switching status [OUT1]
4:	1x yellow LED	Switching status [OUT2]
5:	1x red LED	Status LED = display of faults
6:	Programming button [●]	Selection of the parameters and acknowledgement of the parameter values.
7:	Programming button [▲]	Setting of the parameter values (scrolling by holding pressed, incrementally by pressing once).
8:	Programming button [▼]	Setting of the parameter values (scrolling by holding pressed, incrementally by pressing once).
9:	4-digit alphanumeric display	Indication of the measured distance or reflectivity, the parameters and parameter values.

## 8 Set-up

- ▶ After installation, electrical connection and programming, check whether the device operates correctly.
- ▷ If the device has been correctly set up, the object distance or the object reflectivity is indicated. The settings made last are internally stored by the sensor.

## 9 Menu

 Pressing the [▲] + [▼] buttons at the same time will lead to a return in the menu navigation.

### 9.1 Hysteresis function (distance and reflectivity)

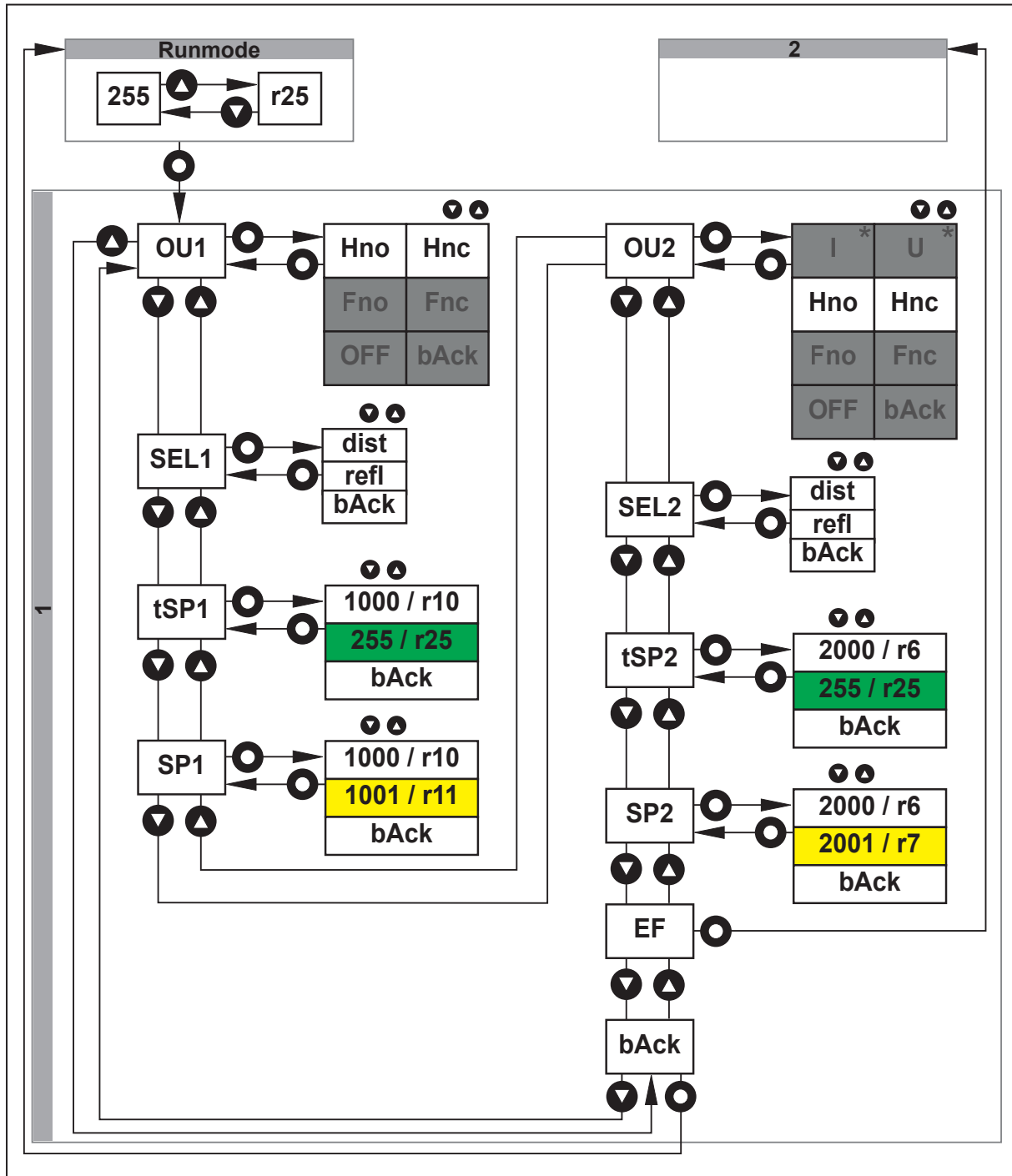

 Current measured value

 Setting value

\*) Only for analogue devices

### 9.2 Window function (distance and reflectivity)

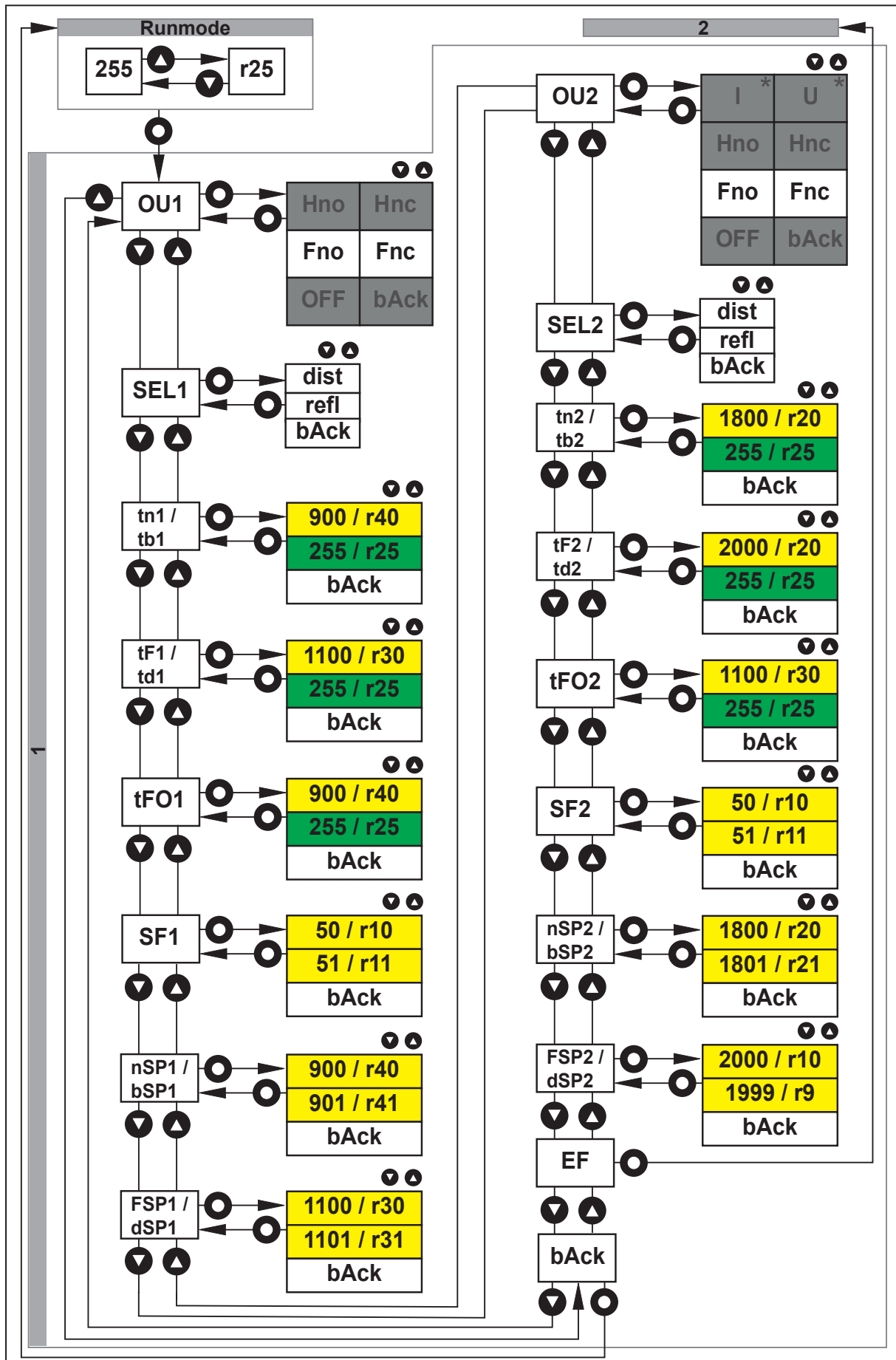

■ Current measured value

■ Setting value

\*) Only for analogue devices

### 9.3 Analogue output for OUT2 (distance and reflectivity)

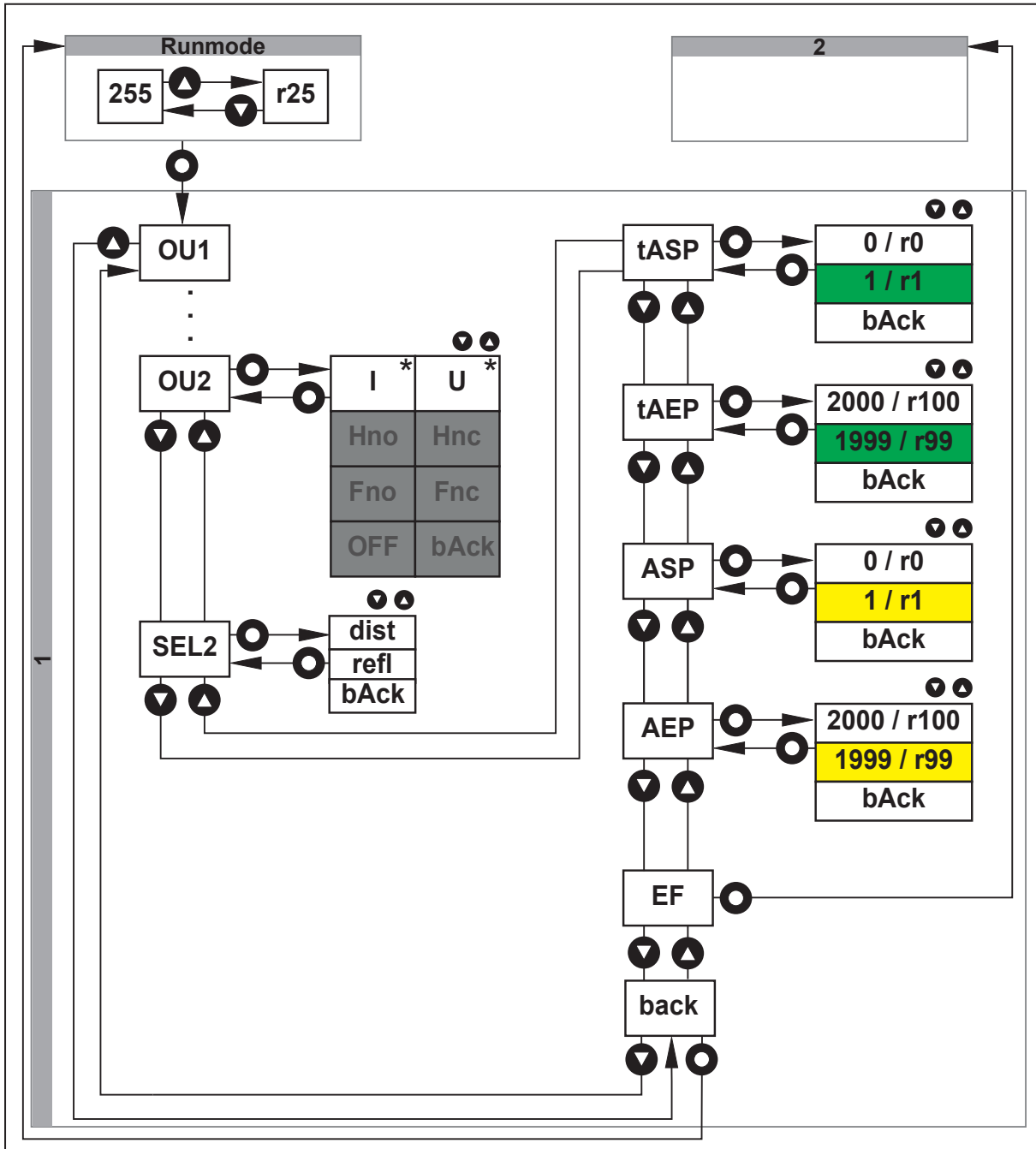

■ Current measured value

■ Setting value

\*) Only for analogue devices

### 9.4 Extended functions – EF

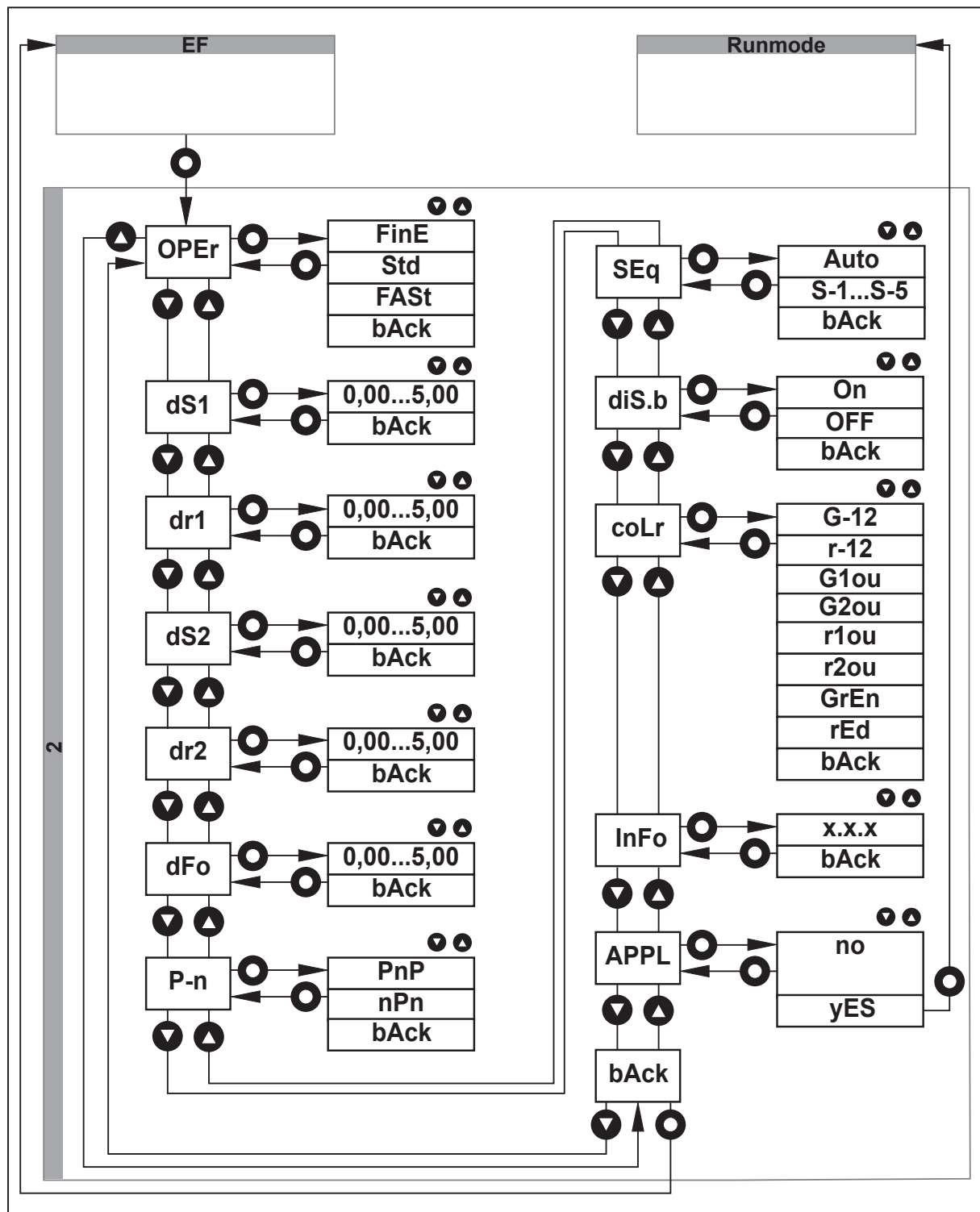

## 10 Operating modes

### 10.1 Run mode

Run mode is the normal operating mode.

After power-on the device is in the Run mode. It carries out its monitoring function and generates output signals according to the set parameters.

The display indicates the current distance or the object reflectivity, the yellow LEDs signal the switching status of the outputs.

The measuring distance is displayed in [mm].

- Value range 30...2200 mm (mm resolution)

The object reflectivity is displayed in [%]:

- Value range 0...999 %
  - A white Kodak gray card has an object reflectivity of approx. 90 % at perpendicular light incidence.
  - A grey Kodak gray card has an object reflectivity of approx. 18 % at perpendicular light incidence.

Reflective surfaces can generate values that are much higher than 90%. Switch between the two measured values via the [▲] or [▼] buttons.

### 10.2 Display mode

Indication of the parameters and the set parameter values.

▶ Briefly press [●].

▷ The device goes to the display mode. Internally it remains in the operating mode.

The set parameter values can be read:

▶ To scroll through the parameters, briefly press [▲/▼].

▶ To display the corresponding parameter value, briefly press [●].

▷ After 30 s the device returns to the Run mode.

### 10.3 Programming mode

Setting the parameter values (→ [General parameter setting](#) □ 25).



## 11 Parameter setting

Internally, the device remains in the operating mode during parameter setting. It continues its monitoring function with the existing parameters until the change has been completed.



For [SPx], [nSPx], [FSPx], [dSPx], [bSPx], [ASP], [AEP], the current and yet unconfirmed value is used for the evaluation. This way, the result of parameter setting can be assessed directly. If the parameter setting is cancelled, the previous value is restored.

### 11.1 General parameter setting



Timeout: If no button is pressed for 30 s during the setting procedure, the device returns to Run mode with unchanged values.

#### 11.1.1 Setting a parameter value

##### Select Parameter

- ▶ Press the [●] button to access menu level 1.
- ▶ Press the [▲/▼] button until the required parameter is displayed.

##### Set parameter value

- ▶ Briefly press the [●] button.
- ▷ The current parameter value is displayed.
- ▶ Keep the [▲/▼] button pressed.
- ▷ The current parameter value flashes for 3 s.
- ▶ Increase / decrease the parameter value step by step by pressing the button once or continuously by holding it down.



As soon as the minimum / maximum parameter value is reached, the display changes to [bAck] and then back to the minimum / maximum parameter value.

##### Acknowledge parameter value

- ▶ Briefly press the [●] button.
- ▷ The display changes back to menu level 1 and is thus effective.

##### Cancelling parameter setting

- ▶ Wait for 30 s or press either [bAck] or the [▲] + [▼] button. If necessary, repeat the last abort option several times to access menu level 0.
- ▷ The display changes back to run mode and shows the current measured value.

#### 11.1.2 Changing from menu level 1 to the menu level 2

- ▶ Repeatedly press the [▲/▼] button until [EF] is displayed.
- ▶ Confirm [EF] with [●].
- ▷ The display changes to menu level 2.

#### 11.1.3 Locking / unlocking the device

The device can be locked electronically to prevent unauthorised setting. On delivery the device is not locked.

### 11.1.3.1 Parameter setting via the device keys

#### Locking

Make sure that the device is in the normal operating mode.

- ▶ Keep [▲] + [▼] pressed (approx. 10 s) until [Lo] is displayed.
- ▷ The device is locked.



[Lo] is displayed briefly if you try to change parameter values on the locked device during operation.

#### Unlocking

- ▶ Keep [▲] + [▼] pressed (approx. 10 s) until [uLo] is displayed.
- ▷ The device is unlocked.

### 11.1.3.2 Parameter setting via IO-Link

- ▶ Call up [Parameters] > [Display settings].
- ▶ Select [Loc].
- ▶ Set [Loc] for locking and [uLoc] for unlocking.

## 11.2 Configuring the basic settings

### 11.2.1 Output configuration

The following output configurations for the outputs [OU1] / [OU2] can be set:

- [I]\*: Analogue output for current.
- [U]\*: Analogue output for voltage.
- [Hno]: Hysteresis function, normally open.
- [Hnc]: Hysteresis function, normally closed.
- [Fno]: Window function, normally open.
- [Fnc]: Window function, normally closed.
- [OFF]: Output off.

\*) Only selectable for analogue devices under [OU2].

#### 11.2.1.1 Parameter setting via the device keys

- ▶ Change to menu level 1.
- ▶ Select [OU1] / [OU2].
- ▶ Confirm by clicking on [●].
- ▷ The set output configuration is displayed.
- ▶ Keep [▲] or [▼] pressed for at least 3 s.
- ▶ Use [▲/▼] to select the output configuration [I]\*, [U]\*, [Hno], [Hnc], [Fno] or [Fnc].
- ▶ Confirm by clicking on [●].
- ▶ The setting is confirmed.

\*) Only selectable for analogue devices under [OU2].

### 11.2.1.2 Parameter setting via IO-Link

- ▶ Call up [Parameter] > [Output configuration].
- ▶ Select the output configuration under [OU1] / [OU2].

## 11.2.2 Measured parameter

For each output, the measured parameter, i.e. distance or reflectivity, can be set.

- [dist]: Distance
- [rEFL]: Reflectivity

### 11.2.2.1 Parameter setting via the device keys

- ▶ Select [SEL1] / [SEL2].
- ▶ Confirm by clicking on [●].
- ▷ Set parameter value is displayed.
- ▶ Keep [▲] or [▼] pressed for at least 3 s.
- ▶ Use [▲/▼] to select the measured parameter [diSt] (distance) / [rEFL] (reflectivity).
- ▶ Confirm by clicking on [●].
- ▶ The setting is confirmed.

### 11.2.2.2 Parameter setting via IO-Link

- ▶ Call up [Parameter] > [Output configuration].
- ▶ Select the measured parameter [Distance] / [Reflectivity] under [SEL1] / [SEL2].

## 11.2.3 Object teach for hysteresis function

The device offers the possibility to teach in [SP1] / [SP2] via an object teach. For this purpose, the object to be detected must be placed in the sensor's detection zone. When the teach-in process is completed, the currently measured value is stored in [SP1] / [SP2].

### 11.2.3.1 Teaching via the device keys

- ▶ Change to menu level 1.
- ▶ Select [OU1] / [OU2].
- ▶ Confirm by clicking on [●].
- ▷ Set parameter value is displayed.
- ▶ Keep [▲] or [▼] pressed for at least 3 s.
- ▶ Use [▲/▼] to select the output configuration [Hno] or [Hnc].
- ▶ Confirm by clicking on [●].
- ▶ Select [SEL1] / [SEL2].
- ▶ Confirm by clicking on [●].
- ▶ Use [▲/▼] to select the measured parameter [diSt] (distance) / [rEFL] (reflectivity).
- ▶ Confirm by clicking on [●].
- ▶ Select [tSPx].
- ▷ The parameter value for [SPx] is displayed.
- ▶ Keep [▲] or [▼] pressed for at least 3 s.

- ▷ The current measured value is displayed. The measured value depends on the current situation.
- ▶ Confirm by clicking on [●].
- ▷ The new measured value flashes once.
- ▷ The taught value is stored in [SPx].



The sensor is aligned to the object. The set point and the reset point are set independently.

### 11.2.3.2 Teaching via IO-Link

- ▶ Call up [Parameter] > [Output configuration].
- ▶ Select the output function [Hno] or [Hnc] under [OU1] / [OU2].
- ▶ Select the measured parameter under [SEL1] / [SEL2].
- ▶ Call up [Parameter] > [Digital output 1] / [Digital output 2].
- ▶ Select [Distance] / [Reflectivity].
- ▶ Click on [Teach SP1] / [Teach SP2].
- ▷ The taught value is stored in [SPx].

### 11.2.4 Teach – switch point for window function

The device offers the possibility to teach in a window via the teach function. For this purpose, the window to be taught in must be in the sensor's detection range. When the teach-in process is completed, the currently measured values are stored in [nSPx] / [FSPx] for distance or [bSPx] / [dSPx] for reflectivity.

If an attempt is made to teach in a window switch point that contradicts the other window switch point of the same output, a corresponding error message is shown instead of the current measured value.

#### 11.2.4.1 Teaching via the device keys

- ▶ Change to menu level 1.
- ▶ Select [OU1] / [OU2].
- ▶ Confirm by clicking on [●].
- ▷ Set parameter value is displayed.
- ▶ Keep [▲] or [▼] pressed for at least 3 s.
- ▶ Use [▲/▼] to select the output configuration [Fno] or [Fnc].
- ▶ Confirm by clicking on [●].
- ▶ Select [SEL1] / [SEL2].
- ▶ Confirm by clicking on [●].
- ▶ Keep [▲] or [▼] pressed for at least 3 s.
- ▶ Use [▲/▼] to select the measured parameter [diSt] (distance) / [rEFL] (reflectivity).
- ▶ Confirm by clicking on [●].
- ▶ Select [tnx] for distance or [tbx] for reflectivity.
- ▷ The parameter value for [nSPx] or [bSPx] is displayed.
- ▶ Keep [▲] or [▼] pressed for at least 3 s.
- ▷ The current measured value is displayed. The measured value depends on the current situation.
- ▶ Confirm by clicking on [●].
- ▷ The new measured value flashes once.

- ▶ Select [tFx] for distance or [tdx] for reflectivity.
- ▷ The parameter value for [FSPx] / [dSPx] is displayed.
- ▶ Keep [▲] or [▼] pressed for at least 3 s.
- ▷ The current measured value is displayed. The measured value depends on the current situation.
- ▶ Confirm by clicking on [●].
- ▷ The new measured value flashes once.
- ▷ The taught values are stored in [nSPx] / [FSPx] or [bSPx] / [dSPx].

#### 11.2.4.2 Teaching via IO-Link

- ▶ Call up [Parameter] > [Output configuration].
- ▶ Select the output function [Fno] or [Fnc] under [OU1] / [OU2].
- ▶ Select the measured parameter under [SEL1] / [SEL2].
- ▶ Call up [Parameter] > [Digital output 1] / [Digital output 2].
- ▶ Select [Distance] / [Reflectivity].
- ▶ Click on [Teach tnx] / [Teach tbx].
- ▷ The measured value for “far” / “bright” is taught.
- ▶ Click on [Teach tFx] / [Teach tdx].
- ▷ The taught value is stored in [nSPx] / [FSPx] or [bSPx] / [dSPx].

### 11.2.5 Teach – 1-point window function

The device offers the possibility to teach in a window with a predefined window width via the teach function. For this purpose, the window to be taught in must be in the sensor's detection range. When the teach-in process is completed, the currently measured values are stored in [nSPx] / [FSPx] for distance or [bSPx] / [dSPx] for reflectivity. The window width is defined using the parameter [SFx].

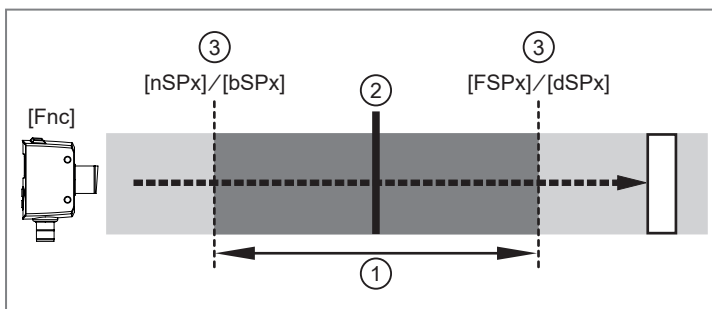

- |                           |                  |                                |
|---------------------------|------------------|--------------------------------|
| ① Window width [SFx]      | [nSPx] / [bSPx]: | Switch point “near” / “bright” |
| ② Object                  | [FSPx] / [dSPx]: | Switch point “far” / “dark”    |
| ③ Resulting switch points |                  |                                |

#### 11.2.5.1 Teaching via the device keys

- ▶ Change to menu level 1.
- ▶ Select [OU1] / [OU2].
- ▶ Confirm by clicking on [●].
- ▷ Set parameter value is displayed.
- ▶ Keep [▲] or [▼] pressed for at least 3 s.

- ▶ Use [▲/▼] to select the output configuration [Fno] or [Fnc].
  - ▶ Confirm by clicking on [●].
  - ▶ Select [SEL1] / [SEL2].
  - ▶ Confirm by clicking on [●].
  - ▶ Use [▲/▼] to select the measured parameter [diSt] (distance) / [rEFL] (reflectivity).
  - ▶ Confirm by clicking on [●].
  - ▶ Select [SFx].
  - ▶ Confirm by clicking on [●].
  - ▷ The set window width is displayed.
  - ▶ Keep [▲] or [▼] pressed for at least 3 s.
  - ▶ Use [▲/▼] to set the window width.
  - ▶ Confirm by clicking on [●].
  - ▶ Select [tFOx].
  - ▶ Confirm by clicking on [●].
  - ▶ Keep [▲] or [▼] pressed for at least 3 s.
  - ▷ The current measured value is displayed. The measured value depends on the current situation.
-  If the current measured value leads to an invalid switch point, this is indicated in the display with [FAr] / [nEAr].
- ▶ Confirm by clicking on [●].
  - ▷ The new measured value flashes once.
  - ▷ The taught values are stored in [nSPx] / [FSPx] or [bSPx] / [dSPx].

#### 11.2.5.2 Teaching via IO-Link

- ▶ Call up [Parameter] > [Output configuration].
- ▶ Select the output function [Fno] or [Fnc] under [OU1] / [OU2].
- ▶ Select the measured parameter under [SEL1] / [SEL2].
- ▶ Call up [Parameter] > [Digital output 1] / [Digital output 2].
- ▶ Select [Distance] / [Reflectivity].
- ▶ Set the window width under [SFx – DIST] or [SFx – REFL].
- ▶ Click on [Teach tFox].
- ▷ A window with the predefined window width around the switch point is taught.
- ▷ The taught value is stored in [nSPx] / [FSPx] or [bSPx] / [dSPx].

## 11.3 Extended functions

### 11.3.1 Operating modes

The device has three operating modes:

- [Fine]: is optimised with regard to “repeatability” and detecting smallest possible object heights.
- [Standard]: combines the detection of small object heights with a higher measuring speed.

- [Fast]: is optimised with regard to measuring speed (“measuring rate / switching rate”) and addresses highly dynamic applications. The max. range with dark objects is lower than with “Fine” and “Standard”.

Operating mode	Velocity	Repeatability	Max. range (black)
[Fine]	+	+++	+++
[Standard]	++	++	+++
[Fast]	+++	+	+



The table provides a preliminary assessment of different applications and the respective operating modes. The rating scale ranges from “+” (less suitable) to “+++” (very suitable).

### 11.3.1.1 Parameter setting via the device keys

- ▶ Change to [EF].
- ▶ Use [▲/▼] to select the parameter [OPEr].
- ▶ Confirm by clicking on [●].
- ▷ Set parameter value is displayed.
- ▶ Keep [▲] or [▼] pressed for at least 3 s.
- ▶ Set the parameter value using [▲/▼].
- ▶ Confirm by clicking on [●].
- ▷ The setting is confirmed.

### 11.3.1.2 Parameter setting via IO-Link

- ▶ Call up [Parameter] > [Basic settings].
- ▶ Select [OPEr].
- ▶ Set one of the options.

## 11.3.2 Setting the delay time for switching outputs

2 delay times can be selected:

- [dS1 / dS2] = switch-on delay
- [dr1 / dr2] = switch-off delay

Setting range [s]: 0...5 s in steps of 0.01 s  
(0 = delay time is not active)



[dS1 / dr1] is the switch-on and switch-off delay for [OU1].  
[dS2 / dr2] is the switch-on and switch-off delay for [OU2].

### 11.3.2.1 Parameter setting via the device keys

- ▶ Change to [EF].
- ▶ Use [▲/▼] to select the parameter:  
[dS1 / dS2] = switch-on delay  
[dr1 / dr2] = switch-off delay
- ▶ Confirm by clicking on [●].
- ▷ Set parameter value is displayed.
- ▶ Keep [▲] or [▼] pressed for at least 3 s.
- ▶ Use [▲/▼] to set the parameters [dS1 / dS2] or [dr1 / dr2].

- ▶ Confirm by clicking on [●].
- ▷ The setting is confirmed.

### 11.3.2.2 Parameter setting via IO-Link

- ▶ Call up [Parameter] > [Digital Output 1 / Digital Output 2].
- ▶ Select [dS1 / dS2] for a switch-on delay and [dr1 / dr2] for a switch-off delay.
- ▶ Set a delay time between 0...5 s.

### 11.3.3 Setting a fault suppression time

A fault suppression time can be set for both outputs.

Setting range [s]: 0...5 s in steps of 0.01 s  
(0 = fault suppression time is not active)



The sensor faults [++], [--] and [ERP] are suppressed.



The set fault suppression time applies to [OU1] and [OU2].

#### 11.3.3.1 Parameter setting via the device keys

- ▶ Change to [EF].
- ▶ Use [▲/▼] to select the parameter [dFo].
- ▶ Confirm by clicking on [●].
- ▷ Set parameter value is displayed.
- ▶ Keep [▲] or [▼] pressed for at least 3 s.
- ▶ Set the parameter value using [▲/▼].
- ▶ Confirm by clicking on [●].
- ▷ The setting is confirmed.

#### 11.3.3.2 Parameter setting via IO-Link

- ▶ Call up [Parameter] > [Output configuration].
- ▶ Select [dFo].
- ▶ Set a fault suppression time between 0...5 s.

### 11.3.4 Output logic (PNP/NPN)

It is possible to set the output logic in the device.

- [PnP]: PNP positive switching
- [nPn]: NPN negative switching

#### 11.3.4.1 Parameter setting via the device keys

- ▶ Change to [EF].
- ▶ Use [▲/▼] to select the parameter [P-n].
- ▶ Confirm by clicking on [●].
- ▷ Set parameter value is displayed.



- ▶ Keep [▲] or [▼] pressed for at least 3 s.
- ▶ Set the parameter value using [▲/▼].
- ▶ Confirm by clicking on [●].
- ▷ The setting is confirmed.

#### 11.3.4.2 Parameter setting via IO-Link

- ▶ Call up [Parameter] > [Basic settings].
- ▶ Select [P-n].
- ▶ Set [PnP] (positive switching) or [nPn] (negative switching).

### 11.3.5 Sequence modulation – mutual interference

Mutual interference of sensors of the same type can be circumvented via sequence modulation.

Two options are available, which can be selected using the parameter [SEq].

- [Auto]:  
The sensor independently detects an interfering sensor and automatically adjusts itself so that no more interference occurs.



Detection of an interfering sensor typically takes less than 1 s.

- [S1]...[S5]:  
In highly dynamic situations (e.g. autonomously operating mobile machines in an environment with various similar sensors), the detection time of an interfering sensor can be a challenge. If this case, it is possible to manually configure the sensors so that they no longer interfere with each other. Five sequences are available for this purpose ([S1]...[S5]). If the case arises, the sequences of the respective sensors must be selected differently so as to avoid mutual interference.



When set via [S1]...[S5], the measuring rate is higher than the values specified in the data sheet [Auto].

Typical measurement rate increase with [S1]...[S5] compared to [Auto]:

In the [FASt] operating mode: approx. 30% higher

In the [Std] operating mode: approx. 10% higher

Manual setting via [S1]...[S5] can therefore also be useful for applications where a particularly high measuring rate is required.

#### 11.3.5.1 Parameter setting via the device keys

- ▶ Change to [EF].
- ▶ Use [▲/▼] to select the parameter [SEq].
- ▶ Confirm by clicking on [●].
- ▷ Set parameter value is displayed.
- ▶ Keep [▲] or [▼] pressed for at least 3 s.
- ▶ Set the parameter value using [▲/▼].
- ▶ Confirm by clicking on [●].
- ▷ The setting is confirmed.

#### 11.3.5.2 Parameter setting via IO-Link

- ▶ Call up [Parameter] > [Basic settings].

- ▶ Select [Sequence modulation] .
- ▶ Set one of the options.

### 11.3.6 Setting the display

2 settings can be selected:

- [On] = the measured value display is activated in the Run mode.
- [OFF] = the measured value display is deactivated in the Run mode. When one button is pressed, the current measured value is displayed for 30 s.



The status LEDs and the PWR status LED remain active even when the display is switched off.

#### 11.3.6.1 Parameter setting via the device keys

- ▶ Change to [EF].
- ▶ Use [▲/▼] to select the parameter [diS.b].
- ▶ Confirm by clicking on [●].
- ▷ Set parameter value is displayed.
- ▶ Keep [▲] or [▼] pressed for at least 3 s.
- ▶ Set the parameter value using [▲/▼].
- ▶ Confirm by clicking on [●].
- ▷ The setting is confirmed.

#### 11.3.6.2 Parameter setting via IO-Link

- ▶ Call up [Parameter] > [Setting of the sensor display].
- ▶ Select [diS.B].
- ▶ Set one of the options.

### 11.3.7 Setting the display colours

Set the display colour for the measured values in Run mode.

The following colour settings are available:

- [G-12]: green display colour when [OUx] switches.
- [r-12]: red display colour when [OUx] switches.
- [Gxou]: green display colour when [OUx] switches.
- [rxou]: red display colour when [OUx] switches.
- [GrEn]: green display colour.
- [rEd]: red display colour.

#### 11.3.7.1 Parameter setting via the device keys

- ▶ Change to [EF].
- ▶ Use [▲/▼] to select the parameter [coLr].
- ▶ Confirm by clicking on [●].
- ▷ Set parameter value is displayed.
- ▶ Keep [▲] or [▼] pressed for at least 3 s.

- ▶ Set the parameter value using [▲/▼].
- ▶ Confirm by clicking on [●].
- ▷ The setting is confirmed.

### 11.3.7.2 Parameter setting via IO-Link

- ▶ Call up [Parameter] > [Setting of the sensor display].
- ▶ Select [coLr].
- ▶ Set one of the options.

## 11.3.8 Device information

### 11.3.8.1 Display via the device keys

- ▶ Change to [EF].
- ▶ Use [▲/▼] to select the parameter [InFo].
- ▶ Confirm by clicking on [●].
- ▷ The current software version is displayed [x.x.x].
- ▶ Confirm by clicking on [●].
- ▷ The display changes back.

### 11.3.8.2 Display via IO-Link

## 11.3.9 Restoring the factory setting

### 11.3.9.1 Reset via the device keys

- ▶ Change to [EF].
- ▶ Use [▲/▼] to select the parameter [APPL].
- ▶ Confirm by clicking on [●].
- ▶ Keep the [▲] or [▼] button pressed for at least 3 s.
- ▶ Press the [▲/▼] button until [YES] appears.
- ▶ Confirm by clicking on [●].
- ▷ The display shows [----].
- ▷ All parameters are reset to factory setting.

### 11.3.9.2 Reset via IO-Link

- ▶ Call up [Parameters] > [Basic settings].
- ▶ Click on the system command [Reset application] or [Back-to-box].
- ▷ The device is reset according to the selected reset method.



The two system commands reset the device in a different way.

[Reset application]: The parameters of the technology-specific application are set to default values. The identification parameters remain unchanged. An upload to the data memory of the master is carried out, if activated in the port configuration of the master.

[Back-to-box]: The parameters of the device are set to the factory settings and communication is blocked until the next time the device is switched off and on. Note: Disconnect the device directly from the master port!

## 11.4 Additional parameter settings via IO-Link

### 11.4.1 Transmitter configuration

Setting to activate and deactivate the transmitter.

5 options can be selected.

- [OFF] (permanently off)
- [ON] (permanently on)
- [OFF\_ExtActive / Switch-off with external signal active] (via input IN1 at pin 5)
- [On\_ExtActive / Switch-on with external signal active] (via input IN1 at pin 5)
- [PDOOut / Controlled by PDOOut] (via IO-Link communication PDOOut)

#### 11.4.1.1 Parameter setting via IO-Link

- ▶ Call up [Parameter] > [Basic settings].
- ▶ Select [Transmitter configuration].
- ▶ Set one of the options.

### 11.4.2 Unit locking

This lock prevents the settings from being changed via the local operating elements on the device.

- [Locked]: The parameters of the device can only be set via IO-Link.
- [Unlocked]: The parameters of the device can be set via IO-Link and via the device keys.



If the device access lock is activated, the following appears in the display when an attempt is made to change a parameter value or to initiate a teach-in process: [s.Loc]

#### 11.4.2.1 Parameter setting via IO-Link

- ▶ Call up [Parameters] > [Other settings].
- ▶ Select [Device access locks. Local parameterization].
- ▶ Set one of the options.

## 12 Display

### 12.1 Devices with switching output

Indication	Possible cause	Switching outputs [SELx] = [dist]				Switching outputs [SELx] = [rEFL]			
		[Hno]	[Hnc]	[Fno]	[Fnc]	[Hno]	[Hnc]	[Fno]	[Fnc]
[otE]	ambient temperature too high	X'	X'	X'	X'	X'	X'	X'	X'
[utE]	ambient temperature too low, laser is switched off	OFF	ON	OFF	ON	OFF	ON	OFF	ON
[nEAR]	object to be measured outside the measuring range – too close	ON	OFF	OFF	ON	X'	X'	X'	X'
[FAr]	object to be measured outside the measuring range – too far	OFF	ON	OFF	ON	X'	X'	X'	X'
[-- ]	too much light, e.g. reflective surface	ON	OFF	OFF	ON	ON	OFF	OFF	ON
[--]	not enough light, no object	OFF	ON	OFF	ON	OFF	ON	OFF	ON
[ErP]	plausibility (e.g. object too fast)	X'	X'	X'	X'	X'	X'	X'	X'
[LoFF]	laser is switched off	OFF	ON	OFF	ON	OFF	ON	OFF	ON
[Err]	teaching failed	X'	X'	X'	X'	X'	X'	X'	X'
[Loc]	button lock is activated	X'	X'	X'	X'	X'	X'	X'	X'
[uLoc]	button lock is deactivated	X'	X'	X'	X'	X'	X'	X'	X'
[s.Loc]	device access lock is active	X'	X'	X'	X'	X'	X'	X'	X'
[SC1] / [SC2] / [SC]	short circuit on OUT1/OUT2								

\*unchanged

### 12.2 Devices with analogue output

Indication	Possible cause	Analogue outputs [SELx] = [dist]		Analogue outputs [SELx] = [rEFL]	
		[I] / [U] [ASP] < [AEP]	[I] / [U] [ASP] > [AEP]	[I] / [U] [ASP] < [AEP]	[I] / [U] [ASP] > [AEP]
[otE]	ambient temperature too high	X'	X'	X'	X'
[utE]	ambient temperature too low, laser is switched off	20.5 mA / 10 V	3.5 mA / 0 V	0 V / 3.5 mA	10 V / 20.5 mA
[nEAR]	object to be measured outside the measuring range – too close	3.5 mA / 0 V	20.5 mA / 10 V	X'	X'
[FAr]	object to be measured outside the measuring range – too far	20.5 mA / 10 V	3.5 mA / 0 V	X'	X'
[-- ]	too much light, e.g. reflective surface	3.5 mA / 0 V	20.5 mA / 10 V	20.5 mA / 10 V	3.5 mA / 0 V
[--]	not enough light, no object	20.5 mA / 10 V	3.5 mA / 0 V	3.5 mA / 0 V	20.5 mA / 10 V
[ErP]	plausibility (e.g. object too fast)	X'	X'	X'	X'

Indication	Possible cause	Analogue outputs [SELx] = [dist]		Analogue outputs [SELx] = [rEFL]	
		[I] / [U] [ASP] < [AEP]	[I] / [U] [ASP] > [AEP]	[I] / [U] [ASP] < [AEP]	[I] / [U] [ASP] > [AEP]
[LoFF]	laser is switched off	20.5 mA / 10 V	3.5 mA / 0 V	3.5 mA / 0 V	20.5 mA / 10 V
[Err]	teaching failed	X'	X'	X'	X'
[Loc]	button lock is activated	X'	X'	X'	X'
[uLoc]	button lock is deactivated	X'	X'	X'	X'
[s.Loc]	device access lock is active				
[SC1] / [SC2] / [SC]	short circuit on OUT1/OUT2				

\*unchanged

## 13 Maintenance, repair and disposal

Faulty sensors must only be repaired by the manufacturer.

- ▶ Keep the front lens of the sensor clean.
- ▶ After use dispose of the unit in an environmentally friendly way in accordance with the applicable national regulations.
- ▶ Do not open the module housing. There are no user-serviceable components inside.

## 14 Factory setting

The factory settings of the parameters are available at [documentation.ifm.com](https://documentation.ifm.com) (PDF – IO-Link interface description).